

# INSTALLATION INSTRUCTIONS

## **1102 - TO SUIT SAAB 9000 CD & CS 88-ON**

### **PLEASE READ INSTRUCTIONS THROUGH BEFORE YOU BEGIN**

**WARNING :** 1. Do not drill, cut weld or otherwise modify the towbar.

2. If you are using electric welding on a motor vehicle, always check that the vehicle is not equipped with electronic engine or instrument management equipment. Failure to do so could destroy any onboard computers. If in doubt, check with the vehicle's manufacturer.

1. Ensure all hardware items have been included.
2. Remove spare wheel.  
**NOTE: CD MODELS ONLY**
3. Remove bumper bar (4 nuts in back panel and 1 screw in each bumper bar end)
4. Fit big dropper plate, bolt it to bumper bar beam and tighten according to torque listing below.
5. Remove shipping hook.
6. Fit reinforcing crossmember inside boot by drilling holes and fitting bolts and plates as per sketch.
7. Place the wider reinforcing bar inside boot, centrally about the car, lining up second hole in reinforcing plate and large shipping hook hole in body (bars are not symmetrical)
8. Placing the other bar underneath the car, drill end holes and bolt both bars together.
9. Using other holes as guides, drill and fit bolts, placing small angle on top of wider bar opposite the shipping hook hole and using longer 8mm bolt.
10. Tighten all bolts to torque listing below.
11. Replace bumper bar.
12. Bolt main part of towbar to dropper plate and car, fitting fabricated bracket (as per sketch over page) depending on which model is being fitted.
13. Tighten all bolts as per torque listing below.
14. Replace spare wheel.
15. Towbar rating sticker to be conspicuously located on inside rear end of the drivers door. (see diagram below)

### **RECOMMENDED ASSEMBLY TORQUE LISTING**

<b><u>Diameter</u></b>	<b><u>Grade 4.6 Bolt</u></b>	<b><u>Grade 8.8 Bolt</u></b>
	<b>Nm</b>	<b>Nm</b>
M6	3.5	9.5
M8	8.6	21.7
M10	16.9	43.4
M12	29.8	77.3
M16	74.0	189.8

**PLEASE NOTE:** You must remove the lug unless you are actually towing if it obscures your number plate.

Failure to do so may result in a fine.

**IMPORTANT:** Please see over for safety chain hook-up procedure.

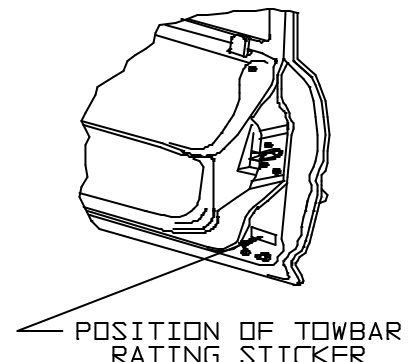

**1102 - TO SUIT SAAB 9000 CD & CS 88-ON**

