

INSTALLATION INSTRUCTIONS

1413 - TO SUIT SUZUKI VITARA V6 3/95-3/98

PLEASE READ INSTRUCTIONS THROUGH BEFORE YOU BEGIN

WARNING : 1. Do not drill, cut weld or otherwise modify the towbar.
2. If you are using electric welding on a motor vehicle, always check that the vehicle is not equipped with electronic engine or instrument management equipment. Failure to do so could destroy any onboard computers. If in doubt, check with the vehicle's manufacturer.

1. Ensure all hardware items have been included.
2. Remove shipping hook from chassis.
3. Hold towbar in position against chassis and fit four (4) longer bolts supplied.
4. Tighten all bolts to torque listing below.
5. Towbar rating sticker to be conspicuously located on inside rear end of the drivers door.
(see diagram below)

RECOMMENDED ASSEMBLY TORQUE LISTING

<u>Diameter</u>	<u>Grade 4.6 Bolt</u>	<u>Grade 8.8 Bolt</u>
	Nm	Nm
M6	3.5	9.5
M8	8.6	21.7
M10	16.9	43.4
M12	29.8	77.3
M16	74.0	189.8

FOR TOWING PURPOSES ONLY

For towing capacity details please refer to vehicle owner's manual or to the manufacturer. Overloading can void your warranties.

PLEASE NOTE: You must remove the lug unless you are actually towing if it obscures your number plate. Failure to do so may result in a fine.

IMPORTANT: Please see over for safety chain hook-up procedure.

23.6.98

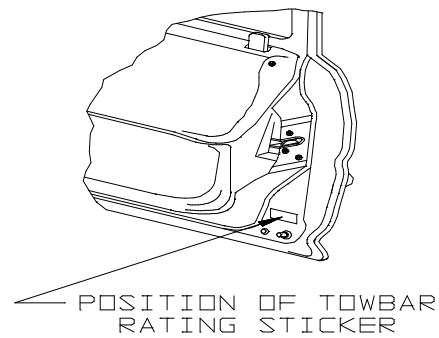

1413

