

INSTALLATION INSTRUCTIONS

1469 - TO SUIT MERCEDES BENZ E CLASS W210 BODY 2/96-ON **PLEASE READ INSTRUCTIONS THROUGH BEFORE YOU BEGIN**

WARNING: 1. Do not drill, cut weld or otherwise modify the towbar.
 2. If you are using electric welding on a motor vehicle, always check that the vehicle is not equipped with electronic engine or instrument management equipment. Failure to do so could destroy any onboard computers. If in doubt, check with the vehicle's manufacturer.

1. Ensure all hardware items have been included.
2. Remove rear bumper bar.
3. Detach rear muffler from rubber supports and allow to hang.
4. Remove rear muffler heat shield.
5. Locate dia 15mm hole in chassis member (behind heat shield), and pop mark 100mm rearward of hole. Drill pop mark dia 15mm.
6. Locate two pop marks in lower face of chassis member at rearmost end. Remove body deadener material to expose.
7. Locate two holes in driver's side as in step 6.
8. Drill four pop marks dia 13mm.
9. Locate two pop marks on outside of rear panel, below tail light assembly, approximately 250mm in from outside of vehicle, in centre of circular depression. Drill large dia 70mm, to expose chassis member.
10. Feed towbar mounting arms through large hole into chassis member to align with holes.
NOTE: Left and right hand arms.
11. Fit towbar into position to align with holes in lower face of chassis (steps 6 and 7) and secure with four bolts and washers supplied. **NOTE:** Remove any excess body deadener material to allow a flush mounting surface between towbar and panel.
12. Fit remaining bolts and plates as indicated in diagram semi tight.
13. Refit bumper bar and centralise towbar cross tube to bumper bar.
14. Tighten all bolts to torque listing below.
15. Refit heat shield, muffler.
16. Towbar rating sticker to be conspicuously located on inside rear end of the driver's door. (see diagram below)

RECOMMENDED ASSEMBLY TORQUE LISTING

<u>Diameter</u>	<u>Grade 4.6 Bolt</u>	<u>Grade 8.8 Bolt</u>
	Nm	Nm
M6	3.5	9.5
M8	8.6	21.7
M10	16.9	43.4
M12	29.8	77.3
M16	74.0	189.8

FOR TOWING PURPOSES ONLY

For towing capacity details please refer to vehicle owner's manual or to the manufacturer. Overloading can void your warranties.

PLEASE NOTE: You must remove the lug unless you are actually towing if it obscures your number plate. Failure to do so may result in a fine.

IMPORTANT: Please see over for safety chain hook-up procedure.

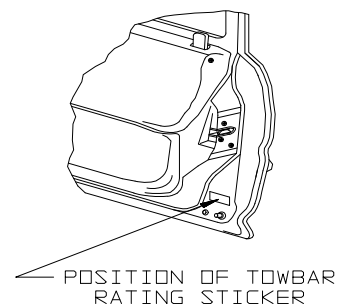

1469 - TO SUIT MERCEDES BENZ E CLASS W210 BODY 2/96-ON

