

INSTALLATION INSTRUCTIONS



RL2262W-TO SUIT TOYOTA AURION SPORTIVO 10-06-ON & CAMRY SPORTIVO 07-2006-ON

PLEASE READ INSTRUCTIONS THROUGH BEFORE YOU BEGIN

WARNING:

1. Do not, drill, cut, weld or otherwise modify the towbar.
2. If you are using electric welding on a motor vehicle, **always** check that the vehicle is not equipped with electronic engine or instrument management equipment. Failure to do so could **destroy** any onboard computers. If in doubt, check with the vehicle's manufacturer.



CAUTION TWO PEOPLE ARE REQUIRED TO FIT THIS PRODUCT

**MAX TOWING CAPACITY, AURION SPORTIVO – 1600/160 Kg
CAMRY SPORTIVO – 1200/120 KG**

- 1 Ensure all hardware items have been included.
- 2 Remove the Rear bumper of the vehicle by following the steps described below.
 - a) Open boot. Remove the carpet, bolt, board and spare wheel from the vehicle boot, in-order to access retention points from inside of boot. Remove the retention points from the inside of the boot on both the LHS & RHS side.
 - b) Remove the mudflaps from the vehicle on both driver & passenger sides (3 fasteners each).
 - c) Remove bolts located on the underside of rear bumper & inside the rear wheel arch on both driver and passenger sides.
 - d) Remove the under tray which is present only for the sportive variants.
 - e) Remove the two clips securing the bumper to the body.
 - f) Remove the panels on the rear bumper to access the bolts securing the bumper to the body on both driver & passenger sides as shown in figure 1.
 - g) Gently pull outwards on the bumper to dislodge it from the vehicle. Remove the OE parking sonar harness located behind the rear bumper if fitted.
- 3 Remove & discard the impact beam. NOTE: Please retain the nuts shown in figure 3 used to mount the impact beam as they are to be used to fit the Rear Panel bracket as shown in drawing of Towbar.
- 4 Lower the exhaust off the rubber mounts (3 places). Remove the 2 bolts holding the exhaust in place and remove the exhaust.
- 5 Remove the exhaust hanger bracket shown in figure 5.
- 6 Remove the heat shield (3 bolts) from the vehicle.
- 7 Manoeuvre the main towbar to the vehicle. The main towbar assembly mounts to the inner side of the chassis shown in figure 4 on both the driver & passenger sides.
- 8 Secure both the chassis brackets on the outer side of the chassis rail loosely using m8 bolts as shown in figures 5 & 6. NOTE: Brackets to be tightened only after the exhaust hanger is fitted back on.
- 9 Refit the exhaust hanger back as in reverse of step 5.
- 10 Tighten the brackets to the chassis as shown in figures and also bolt it to the main towbar assembly on both driver & passenger sides using M10 bolts (3 places) on both sides.
- 11 Offer rear-panel bracket to the vehicle. These brackets are bolted on to the rear panel using the nuts that were used to mount the impact beam and bolted on to the main towbar assembly as shown in figure 6.
- 12 Temporarily refit the rear bumper to the vehicle and mark the location of the towbar side arms. Cut the bumper at two places as shown in figures 7&8. Allow for 3-5mm on either side of the side arms. NOTE: Always mark location of towbar side arms from inside of bumper. Cut inner bumper skin only. Do not cut outer skirt.
- 13 Trim the inner bumper as shown in figure 9. Also trim the outer bumper or skirt as shown in figure 10.
- 14 For **Camry Sportivo** variants only cut-off tab from the inside of outer skirt or bumper as shown in Figure 11.
- 15 Fasten all hardware loosely as per diagram below then tighten all hardware to torque listing.
- 16 Refit bumper in reverse of steps 2.
- 17 Towbar sticker to be consciously located on inside rear end of the driver's door. (see diagram below)

NOTE: Hayman Reese recommends that you check your tow ball to ensure it complies with the Australian standard AS 4177.2.

INSTALLATION INSTRUCTIONS



RL2262W-TO SUIT TOYOTA AURION SPORTIVO 10-06-ON & CAMRY SPORTIVO 07-2006-ON PLEASE READ INSTRUCTIONS THROUGH BEFORE YOU BEGIN

RECOMMENDED ASSEMBLY TORQUE LISTING

<u>Diameter</u>	<u>Grade 8.8 Bolt</u>
	Nm
M6	9.5
M8	21.7
M10	43.4
M12	77.3
M16	189.8

FOR TOWING PURPOSES ONLY
For towing capacity details please refer to vehicle owner's manual or to the manufacturer. Overloading can void your warranties.

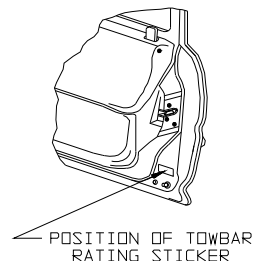

FIG 1: Shows the clips securing the bumper to car.



FIG 2: Shows impact beam on car



FIG 3: Discard impact beam, but retain nuts shown.



INSTALLATION INSTRUCTIONS



**RL2262W-TO SUIT TOYOTA AURION SPORTIVO 10-06-ON &
CAMRY SPORTIVO 07-2006-ON**
PLEASE READ INSTRUCTIONS THROUGH BEFORE YOU BEGIN

FIG 4: Shows the inside of chassis rails and the holes where the towbar mounts

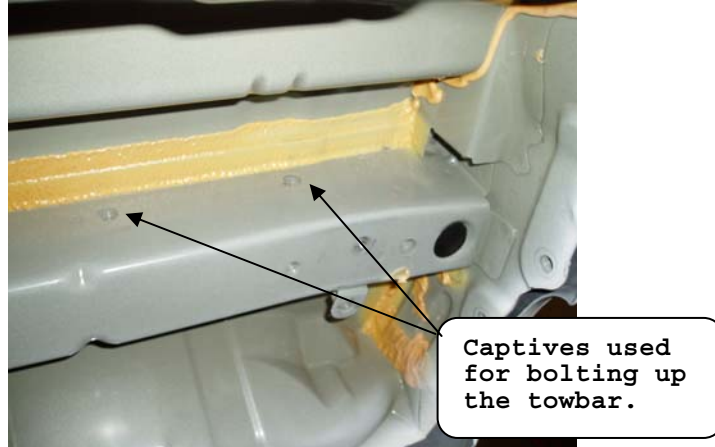

FIG 5: Shows exhaust bracket and Bolt-on side bracket being secured on.

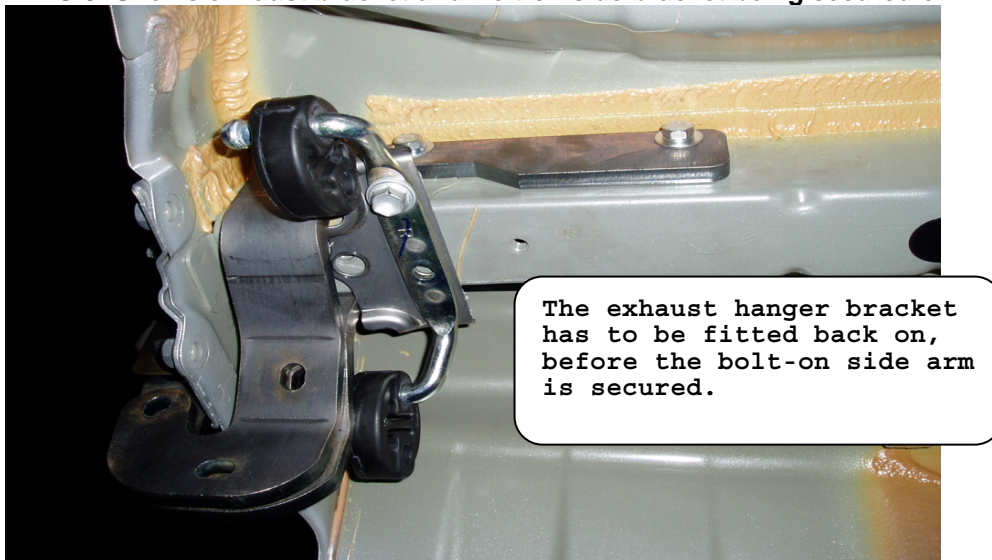
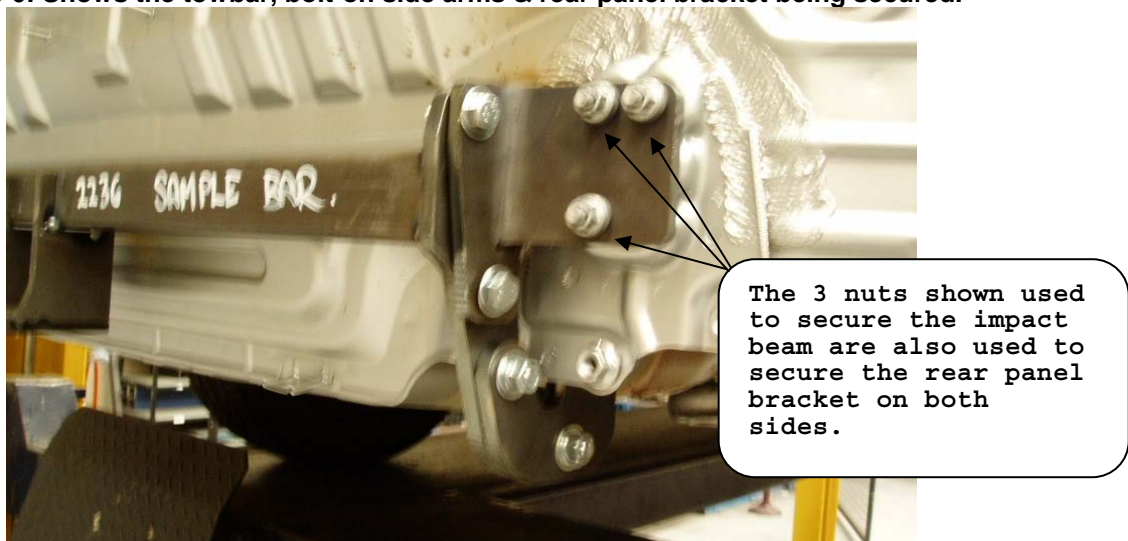

FIG 6: Shows the towbar, bolt-on side arms & rear panel bracket being secured.



INSTALLATION INSTRUCTIONS



RL2262W-TO SUIT TOYOTA AURION SPORTIVO 10-06-ON & CAMRY SPORTIVO 07-2006-ON PLEASE READ INSTRUCTIONS THROUGH BEFORE YOU BEGIN

TOYOTA AURION SPORTIVO & CAMRY SPORTIVO RL2262W TOWBAR ASSEMBLY SHOWN

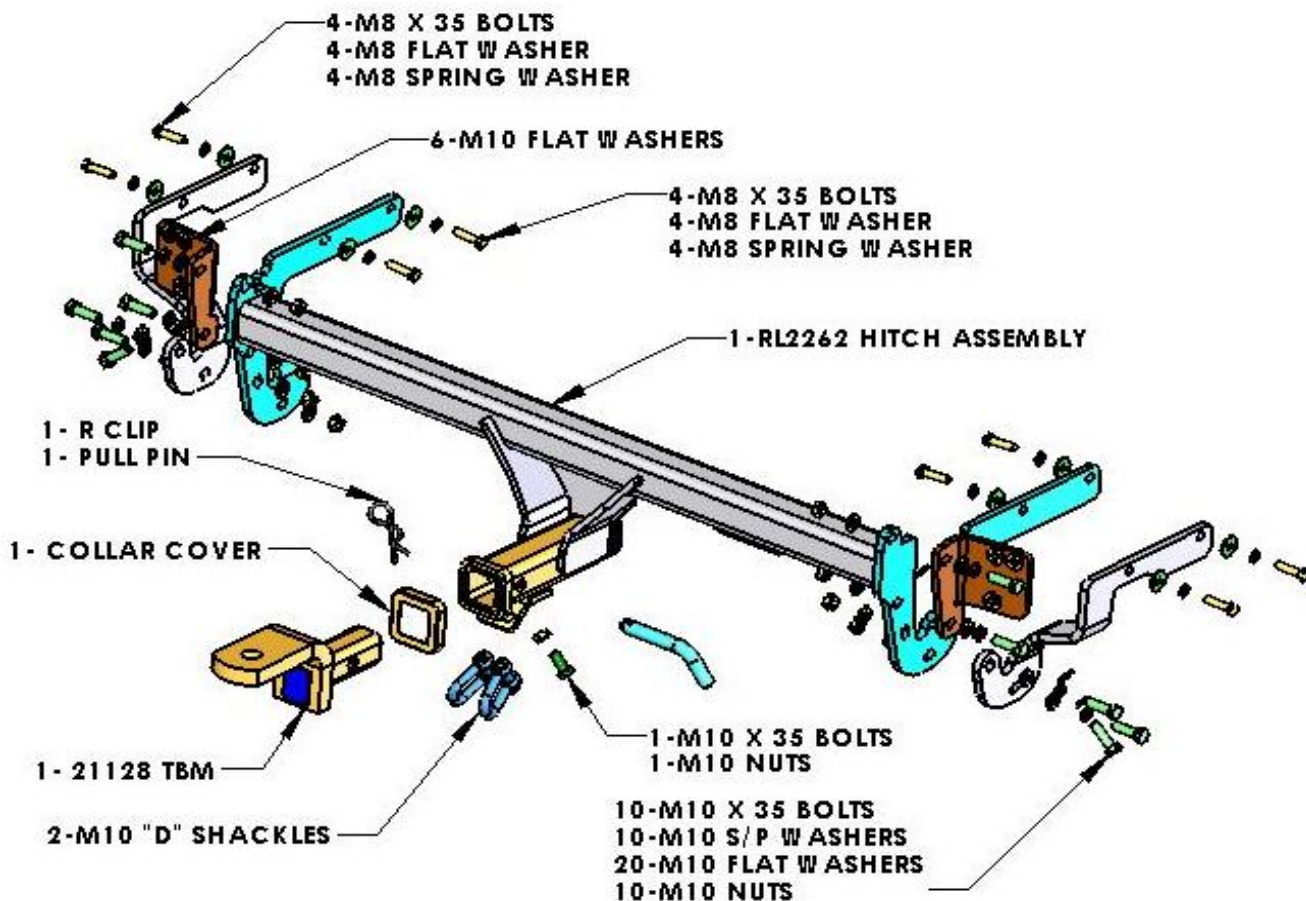
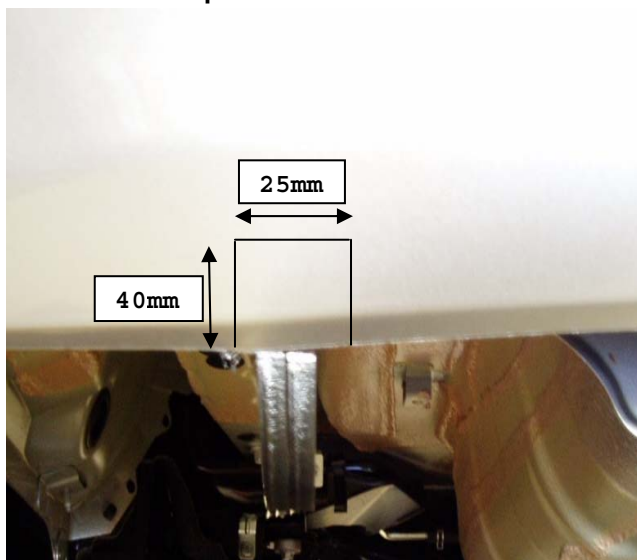

FIG 7: Bumper cut on both sides for the side arms.

FIG 8: Cut bumper shown.



NOTE: Mark location of towbar side arms from inside of bumper. Cut inner bumper skin only. Do not cut outer skirt.

INSTALLATION INSTRUCTIONS



RL2262W-TO SUIT TOYOTA AURION SPORTIVO 10-06-ON & CAMRY SPORTIVO 07-2006-ON
PLEASE READ INSTRUCTIONS THROUGH BEFORE YOU BEGIN

FIG 9: Shows Inner bumper cut for Sportivo variants.

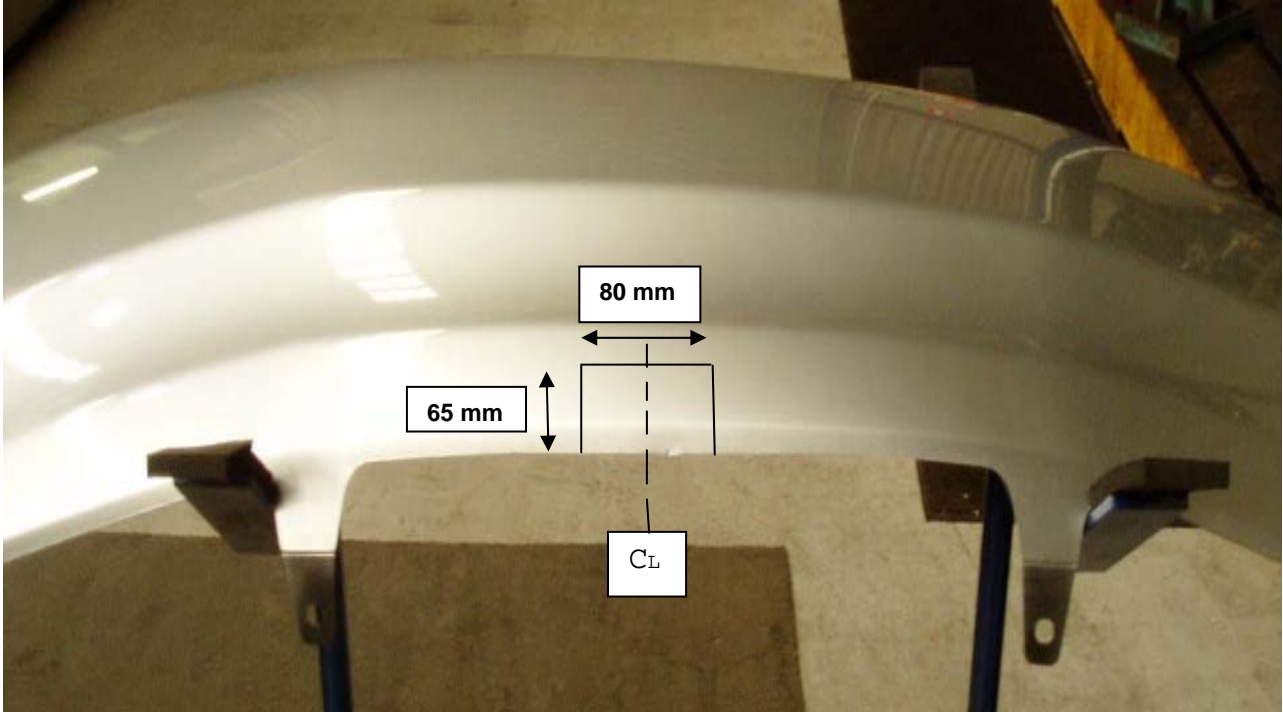

FIG 10: Shows outer bumper cut for the SPORTIVO variant. The two centremost tabs need to be cut off as well from the outer bumper.

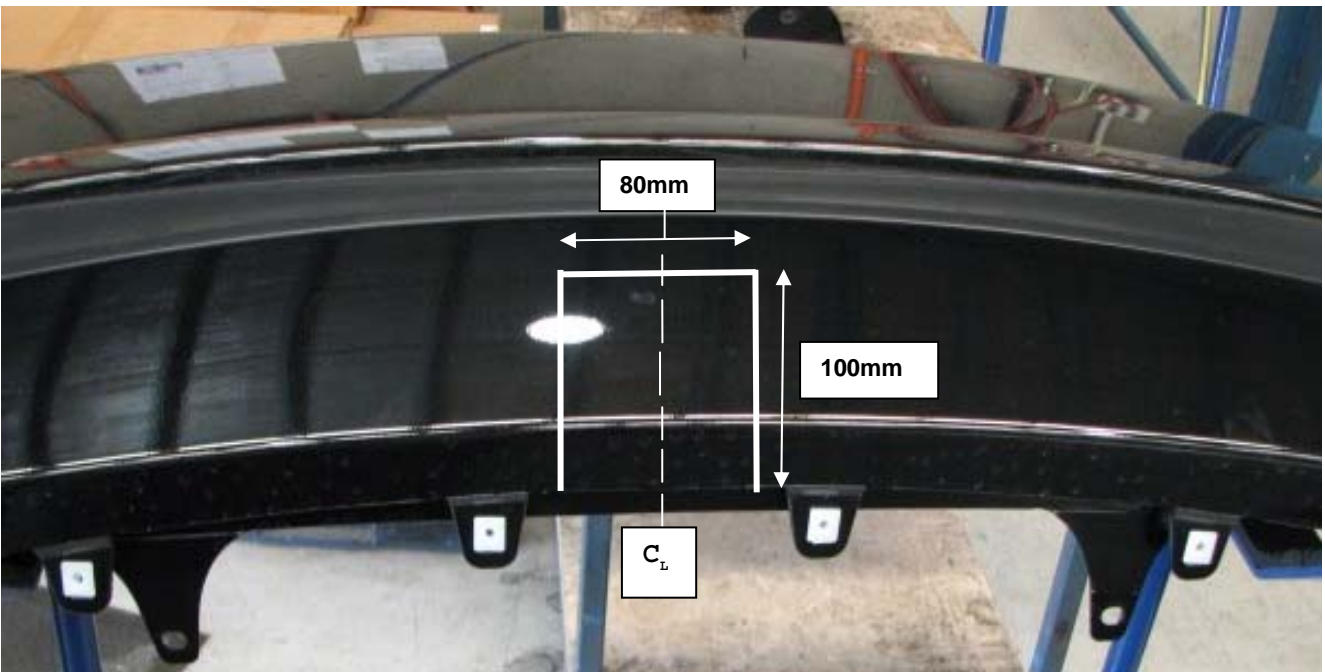

FIG 11: For Camry sportive variants Cut-off tab in the inside of outer bumper as shown, in the passenger side only.

INSTALLATION INSTRUCTIONS



**RL2262W-TO SUIT TOYOTA AURION SPORTIVO 10-06-ON &
CAMRY SPORTIVO 07-2006-ON**
PLEASE READ INSTRUCTIONS THROUGH BEFORE YOU BEGIN



NOTE
BOLT-ON SIDE BRACKETS TO BE BOLTED ON TO THE
SIDE ARM OF THE ASSEMBLY AS SHOWN
BOLT PACK TO BE SHRINK WRAPPED TO THE MAIN ASSEMBLY
THESE M10 X 45 BOLTS, NUTS & WASHERS ARE FOR
ASSEMBLY & LOGISTICS PURPOSES ONLY, THEN BOLTS
SHOULD BE DISCARDED UPON INITIAL FITMENT.

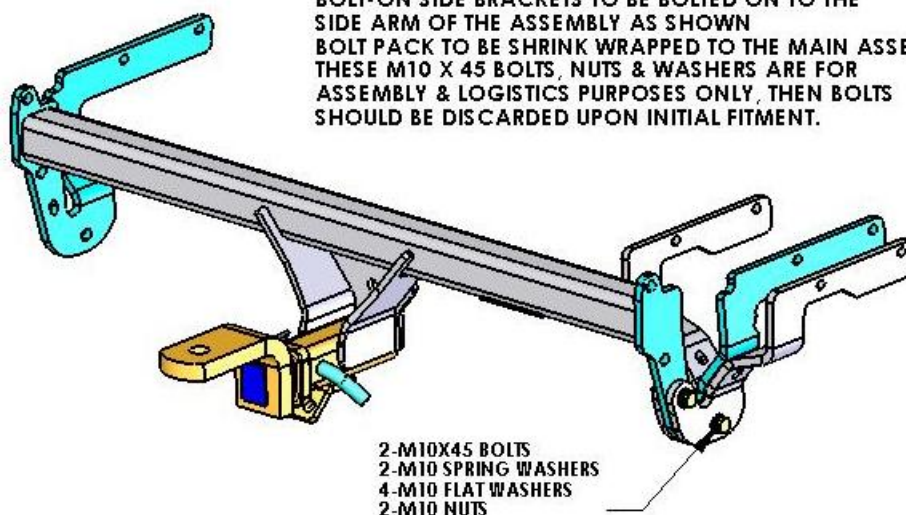

PLEASE NOTE: It is advised to remove lug from receiver box when not actually towing so as to produce a clear view of the vehicles registration plate if obscured, and to also provide increased departure angle.

HAYMAN REESE
PART No: 100084-WL
TOYOTA CAMRY/AURION

INSTALLATION INSTRUCTIONS

PLEASE ENSURE THAT INSTRUCTIONS ARE UNDERSTOOD PRIOR TO FITMENT

Wiring Loom Installation Instructions

TOYOTA CAMRY/AURION
Part No: 100084-WL

Tail Harness Length Required: 1800mm
ECU Required: 04826
RPA Override Switch Part No: 04848 (If Fitted)

Wiring Loom Installation Time: Approx 40 Mins

Issue Date 05-10-09

Page 1

Part No: 100084-WL

Hayman Reese (Cequent)
PO Box 4050, Dandenong South VIC 3164
Phone 1800 812 017 Email info@haymanreese.com.au

www.haymanreese.com.au



HAYMAN REESE
PART No: 100084-WL
TOYOTA CAMRY/AURION
INSTALLATION INSTRUCTIONS

PLEASE ENSURE THAT INSTRUCTIONS ARE UNDERSTOOD PRIOR TO FITMENT

1. In the luggage compartment, remove the luggage compartment floor carpet (1).

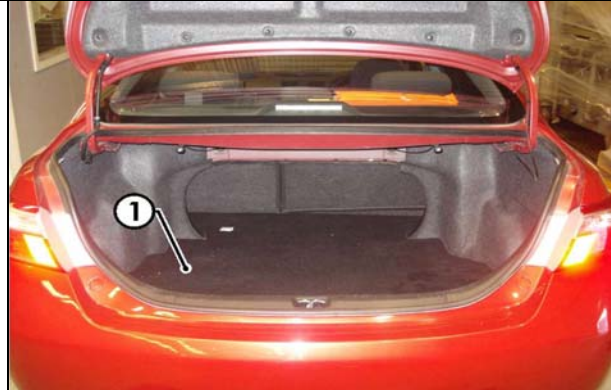

2. Remove the luggage compartment rear trim (1) by removing the trim clips.



3. Remove the LHS luggage compartment trim (1) by removing the fasteners. Repeat for RHS trim.

NOTE: Steps 4 to 8 only for vehicles that are not pre-wired. Go to Step 9 if the vehicle is pre-wired.

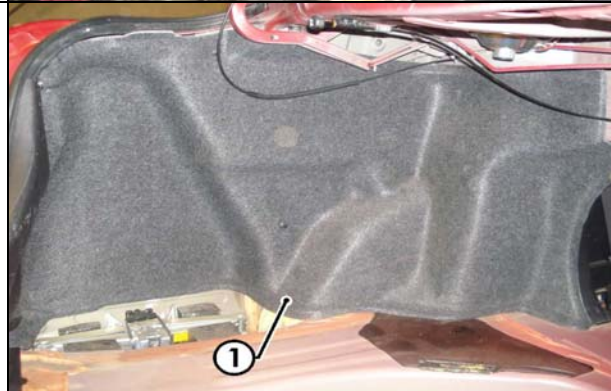

Issue Date 05-10-09

Page 2

Part No: 100084-WL

Hayman Reese (Cequent)
PO Box 4050, Dandenong South VIC 3164
Phone 1800 812 017 Email info@haymanreese.com.au

www.haymanreese.com.au



HAYMAN REESE
PART No: 100084-WL
TOYOTA CAMRY/AURION
INSTALLATION INSTRUCTIONS

PLEASE ENSURE THAT INSTRUCTIONS ARE UNDERSTOOD PRIOR TO FITMENT

4. Remove the rear passenger seat from the vehicle (1).



5. Remove the LHS rear passenger sill trim (1).



6. Remove the backseat LHS rear seat support (1) by removing the 10mm bolt that is holding it in.



Issue Date 05-10-09

Page 3

Part No: 100084-WL

Hayman Reese (Cequent)
PO Box 4050, Dandenong South VIC 3164
Phone 1800 812 017 Email info@haymanreese.com.au

www.haymanreese.com.au



HAYMAN REESE
PART No: 100084-WL
TOYOTA CAMRY/AURION
INSTALLATION INSTRUCTIONS

PLEASE ENSURE THAT INSTRUCTIONS ARE UNDERSTOOD PRIOR TO FITMENT

7. Dislodge the 'B' pillar lower trim (1).



8. Remove the front passenger sill trim (1), kick panel (2) and remove the 2 bolts (3) from the underside of the glove box. Open the glove compartment and remove the three top screws (4).

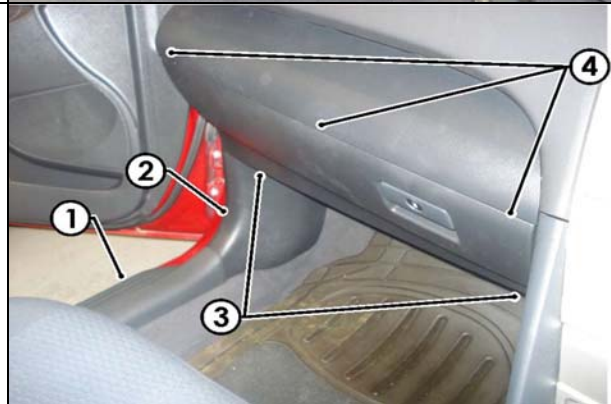

9. Underneath the vehicle at the rear LHS quarter, locate and remove the grommet (1) from the vehicle.

Using a step drill, drill the grommet hole to $\text{\O}31\text{mm}$.
Mount the Tail Harness socket using M4 fasteners.
Route the Tail Harness (tail length 1800mm) connector into the grommet hole and move the grommet along the harness into position ensuring that the Tail Harness grommet is seated correctly. Secure grommet with a cable tie.



Issue Date 05-10-09

Page 4

Part No: 100084-WL

Hayman Reese (Cequent)
PO Box 4050, Dandenong South VIC 3164
Phone 1800 812 017 Email info@haymanreese.com.au

www.haymanreese.com.au



HAYMAN REESE
PART No: 100084-WL
TOYOTA CAMRY/AURION
INSTALLATION INSTRUCTIONS

PLEASE ENSURE THAT INSTRUCTIONS ARE UNDERSTOOD PRIOR TO FITMENT

10. NOTE: For vehicles that are not pre-wired go to Step 11. Vehicles that are pre-wired, continue below:

House the Power Harness orange wire terminal (1) into Pin 2 of the female Power Harness patch connector (2).

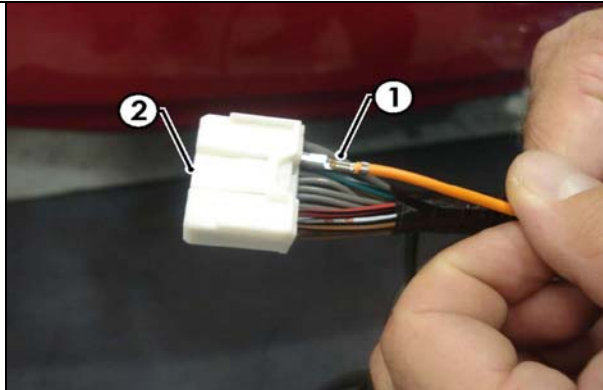

11. Disconnect the vehicle connector (1) and then patch the Trailer Patch Harness (P/No: 100084-WL) connectors (2) in between.

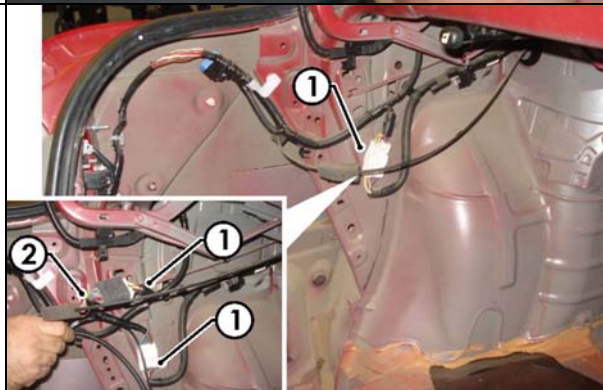

12. Connect the Tail Harness 8-way male connector (1) to the Trailer Patch Harness (P/No: 100084-WL) 8-way female connector (2).

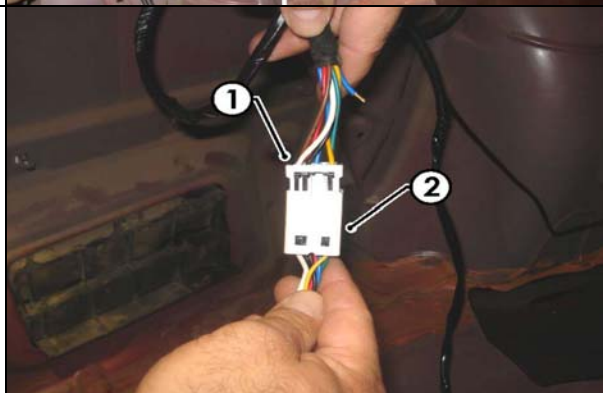

Issue Date 05-10-09

Page 5

Part No: 100084-WL

Hayman Reese (Cequent)
PO Box 4050, Dandenong South VIC 3164
Phone 1800 812 017 Email info@haymanreese.com.au

www.haymanreese.com.au



HAYMAN REESE
PART No: 100084-WL
TOYOTA CAMRY/AURION
INSTALLATION INSTRUCTIONS

PLEASE ENSURE THAT INSTRUCTIONS ARE UNDERSTOOD PRIOR TO FITMENT

Locate the 12-way female ECU connector (1) and plug it into the ECU (P/No: 04826) (2). Then secure the ECU using double sided tape on the outer side of the inner boot skin (3).

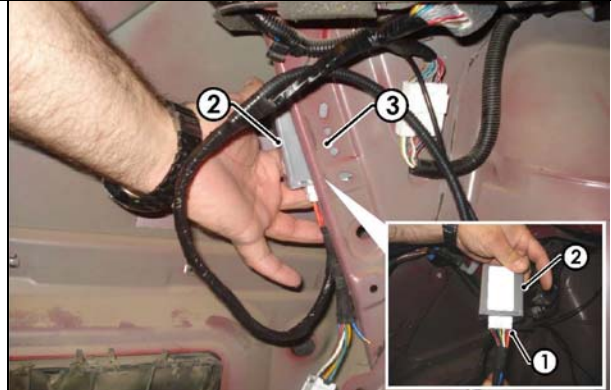

13. Secure the Power Harness ring terminal onto the grounding point (1) located at the rear of the luggage compartment area.

Note: Vehicles that are pre-wired, go to Step 20. Vehicles that are not pre-wired, continue to Step 15.

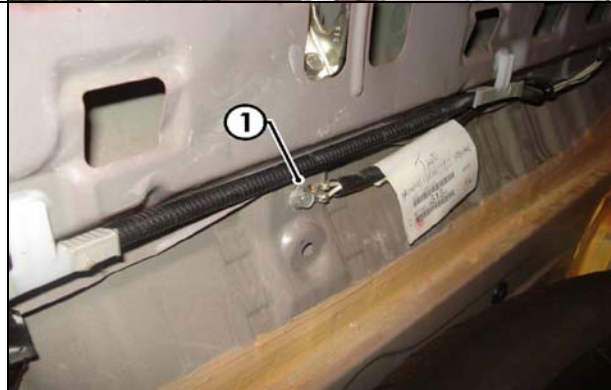

14. From the luggage compartment area, route the Power Harness ORANGE terminal (1) wire along the vehicle harness through the 'C' and 'B' pillars.

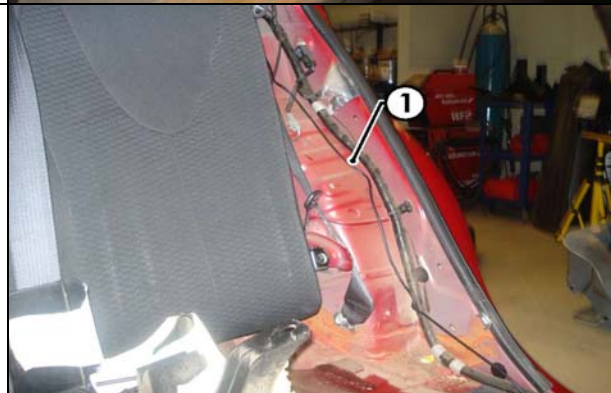

Issue Date 05-10-09

Page 6

Part No: 100084-WL

Hayman Reese (Cequent)
PO Box 4050, Dandenong South VIC 3164
Phone 1800 812 017 Email info@haymanreese.com.au

www.haymanreese.com.au



HAYMAN REESE
PART No: 100084-WL
TOYOTA CAMRY/AURION
INSTALLATION INSTRUCTIONS

PLEASE ENSURE THAT INSTRUCTIONS ARE UNDERSTOOD PRIOR TO FITMENT

15. Continue routing the Power Harness ORANGE wire (1) towards the glove compartment cavity junction box.



16. At the junction box remove the 26-way connector unclipping the lever lock (1).

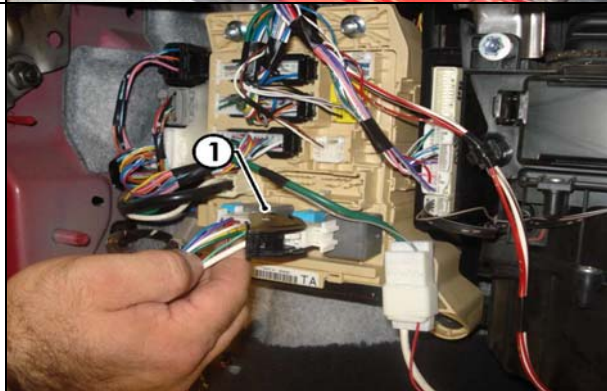

17. Slide open the 26-way connector black lever (1).

Unhouse the secondary lock on the 26-way connector (2).

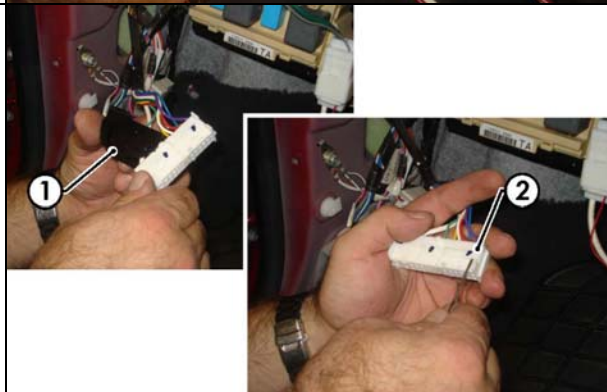

Issue Date 05-10-09

Page 7

Part No: 100084-WL

Hayman Reese (Cequent)
PO Box 4050, Dandenong South VIC 3164
Phone 1800 812 017 Email info@haymanreese.com.au

www.haymanreese.com.au



HAYMAN REESE
PART No: 100084-WL
TOYOTA CAMRY/AURION
INSTALLATION INSTRUCTIONS

PLEASE ENSURE THAT INSTRUCTIONS ARE UNDERSTOOD PRIOR TO FITMENT

18. House the Power Harness ORANGE terminal (1) into Pin 17 (2) of the 26-way connector.

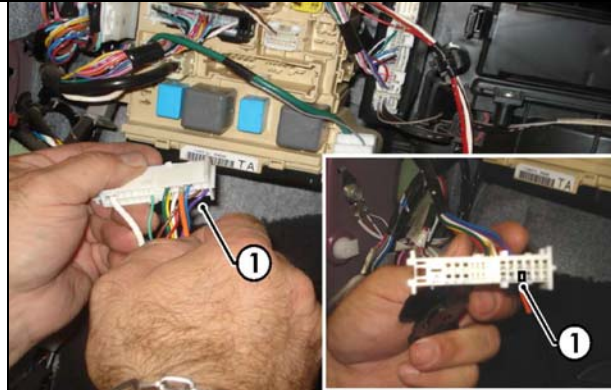

19. Underneath the Junction Box, remove the fuse panel cover.

Insert a 20 amp mini fuse into the fuse panel as shown (1) (in the position between the 30 amp and 7.5 amp fuses).

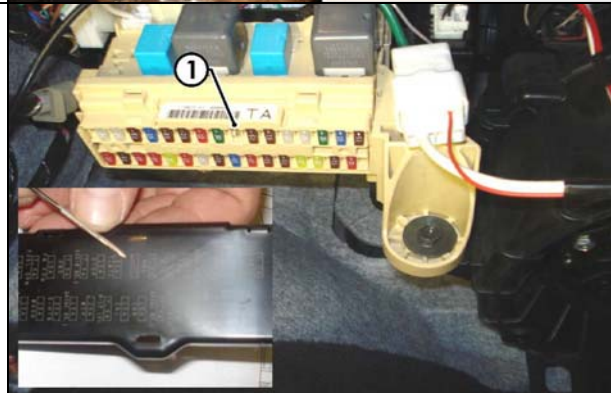

20. Test the Tail Harness function using a Light Board or multimeter.

- 21. Secure the Harness using cables ties.
- 22. Refit all removed parts and secure all fasteners ensuring there are no squeaks or rattles.
- 23. Place instructions in glove box after fitment.

Issue Date 05-10-09

Page 8

Part No: 100084-WL

Hayman Reese (Cequent)
PO Box 4050, Dandenong South VIC 3164
Phone 1800 812 017 Email info@haymanreese.com.au

www.haymanreese.com.au

