

INSTALLATION INSTRUCTIONS



R2488-TO SUIT 2007-on LAND ROVER DEFENDER 130 CAB CHASSIS
ENSURE INSTRUCTIONS ARE UNDERSTOOD BEFORE INSTALLATION.

Rating Braked 3500 Kg

Rating Unbraked 750 Kg

Max Static Ball Load 250 Kg

Warning:

1. Do not, drill, cut, weld or otherwise modify the towbar.
2. If you are using electric welding on a motor vehicle, **always** check that the vehicle is not equipped with electronic engine or instrument management equipment. Failure to do so could **destroy** any onboard computers. If in doubt, check with the vehicle's manufacturer.

1. **General:** Ensure all hardware items have been included refer to assembly diagram.
2. It is recommended that the instructions are read through and completely understood before making any attempt to fit this product.
3. Be wary of any changes to vehicle designs or other accessories that may conflict with the installation of this product.
4. Before drilling ensure that the area is clear of fuel, electrical & other components.
5. All holes drilled into the body panels shall have all burrs & swarf removed then coated with a suitable rust preventative paint.
6. The high tensile fasteners supplied with this product were used to achieve the specified rating. If replacement is required ensure that fasteners of the same rating & quality are used. Contact an authorised **Hayman Reese** dealer if further information is required.
7. Ensure that all hardware is fastened to torque list below check fasteners on regular basis.
8. Towbar load rating sticker provided with this product shall be conspicuously located on inside rear end of the driver's door. **(See diagram below).**
9. Hayman Reese recommends that you check your tow ball to ensure that it complies with the Australian standards **AS 4177.2**.
10. **PLEASE NOTE:** It is advised to remove your lug or tbn when not actually towing so as to produce a clear view of the vehicles registration plate if obscured, and to also provide maximum available departure angle.

Tow bar Maintenance and Care.

Hayman Reese recommends that bolt torque's, as listed below, are routinely and regularly inspected and checked for correct tension. Replace any worn or defective parts.

We recommended to remove Tow Ball Mounts (TBM's, tongues or lugs) when not being used for any considerable length of time.

So as to avoid injury, when not towing it is suggested that the tongue, Pull Pin and R-clip are removed then stored in a safe, clean and dry place, away from excessive moisture.

Hitch Pull Pins and spring "R" clips are regularly checked for proper installation. Replace any worn or defective parts.

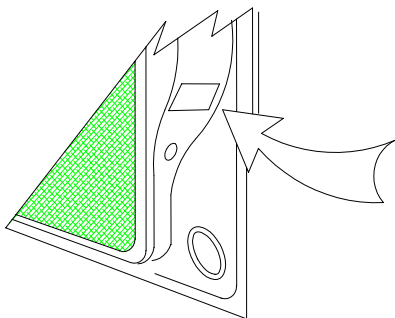

Place load rating sticker
inside driver's door here

RECOMMENDED ASSEMBLY TORQUE LISTING

Diameter Grade 8.8 Bolt

M6	9.5 Nm
M8	21.7 Nm
M10	43.4 Nm
M12	77.3 Nm
M16	189.8 Nm

FOR TOWING PURPOSES ONLY

For towing capacity details please refer to vehicle owner's manual or to the manufacturer. Overloading can void your warranties.

INSTALLATION INSTRUCTIONS



R2488-TO SUIT 2007-on LAND ROVER DEFENDER 130 CAB CHASSIS
ENSURE INSTRUCTIONS ARE UNDERSTOOD BEFORE INSTALLATION.

1. Ensure all hardware items have been included.
2. Remove two lock nuts and washers from shipping hook bolts.
3. Lift towbar up into position and fit shipping hook bolts through holes in towbar side plates.
4. Fit new M10 nuts and spring washers semi tight.
5. Swing towbar upwards and align holes in rear mounting plate with four M12 tapped holes in rear chassis cross member and fit M12x35 bolts, and spring washers as per drawing.
6. Fit three M10x30 bolts and spring washers through angle iron and into captive nuts of chassis cross member.
7. Tighten all bolts to torque listing below.
8. Towbar rating sticker to be conspicuously located on the inside of the driver door.
(See diagram below)

