

HAYMAN REESE
PART No: 03161RW
FIAT DOBLO 263

INSTALLATION INSTRUCTIONS

PLEASE ENSURE THAT INSTRUCTIONS ARE UNDERSTOOD PRIOR TO FITMENT
PLACE THESE INSTRUCTIONS IN THE VEHICLE'S GLOVEBOX AFTER INSTALLATION IS COMPLETED



Installation Time: Approx 100 Mins

Towbar Installation Instructions

Towbar capacity

FIAT DOBLO 263 CL4

Part Number 03161RW	Max Towing Braked	1500kg
	Max Towing Unbraked	500kg
	Max Static Ball Load	150kg
Tail Harness Length Required: 1800 mm		

Hayman Reese (Cequent)
PO Box 4050, Dandenong South VIC 3164
Phone 1800 812 017 Email info@haymanreese.com.au

www.haymanreese.com.au



HAYMAN REESE
PART No: 03161RW
FIAT DOBLO 263

INSTALLATION INSTRUCTIONS

PLEASE ENSURE THAT INSTRUCTIONS ARE UNDERSTOOD PRIOR TO FITMENT
PLACE THESE INSTRUCTIONS IN THE VEHICLE'S GLOVEBOX AFTER INSTALLATION IS COMPLETED

Warning:

1. Do not, drill, cut, weld or otherwise modify the towbar.
2. If you are using electric welding on a motor vehicle, **always** check that the vehicle is not equipped with electronic engine or instrument management equipment. Failure to do so could **destroy** any on board computers. If in doubt, check with the vehicle's manufacturer.
3. If TBM is used in inverted position tow ball may make contact with rear tailgate when lowered, which could cause damage.

General:

1. Ensure all hardware items have been included refer to assembly diagram.
2. It is recommended that the instructions are read through and completely understood before making any attempt to fit this product.
3. Be wary of any changes to vehicle designs or other accessories that may conflict with the installation of this product.
4. Before drilling ensure that the area is clear of fuel, electrical & other components.
5. All holes drilled into the body panels shall have all burrs & swarf removed then coated with a suitable rust preventative paint.
6. The high tensile fasteners supplied with this product were used to achieve the specified rating. If replacement is required ensure that fasteners of the same rating & quality are used. Contact an authorised **Hayman Reese** dealer if further information is required.
7. Ensure that all hardware is fastened to torque list below check fasteners on regular basis.
8. Towbar load rating sticker provided with this product shall be conspicuously located on inside rear end of the driver's door. **(See diagram below).**
9. Hayman Reese recommends that you check your tow ball to ensure that it complies with the Australian standards **AS 4177.2**.
10. **PLEASE NOTE:** It is advised to remove your LUG or TBM when not actually towing so as to produce a clear view of the vehicles registration plate if obscured, and to also provide maximum available departure angle.

Tow bar Maintenance and Care.

Hayman Reese recommends that bolt torque's, as listed below, are routinely and regularly inspected and checked for correct tension. Replace any worn or defective parts.

We recommended to remove Tow Ball Mounts (TBM's, tongues or lugs) when not being used for any considerable length of time.

So as to avoid injury, when not towing it is suggested that the tongue, Pull Pin and R-clip are removed then stored in a safe, clean and dry place, away from excessive moisture.

Hitch Pull Pins and spring "R" clips are regularly checked for proper installation. Replace any worn or defective parts.

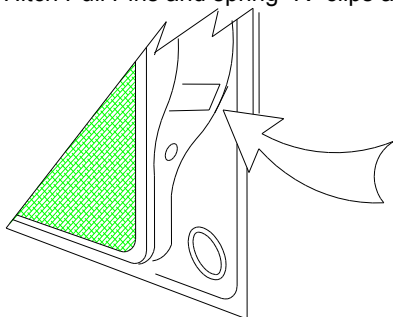

**Place load rating sticker
inside driver's door here**

FOR TOWING PURPOSES ONLY
**For towing capacity details please refer to vehicle
owner's manual or to the manufacturer. Overloading can
void your warranties.**

Hayman Reese (Cequent)
PO Box 4050, Dandenong South VIC 3164
Phone 1800 812 017 Email info@haymanreese.com.au

www.haymanreese.com.au



HAYMAN REESE
PART No: 03161RW
FIAT DOBLO 263

INSTALLATION INSTRUCTIONS

PLEASE ENSURE THAT INSTRUCTIONS ARE UNDERSTOOD PRIOR TO FITMENT
 PLACE THESE INSTRUCTIONS IN THE VEHICLE'S GLOVEBOX AFTER INSTALLATION IS COMPLETED

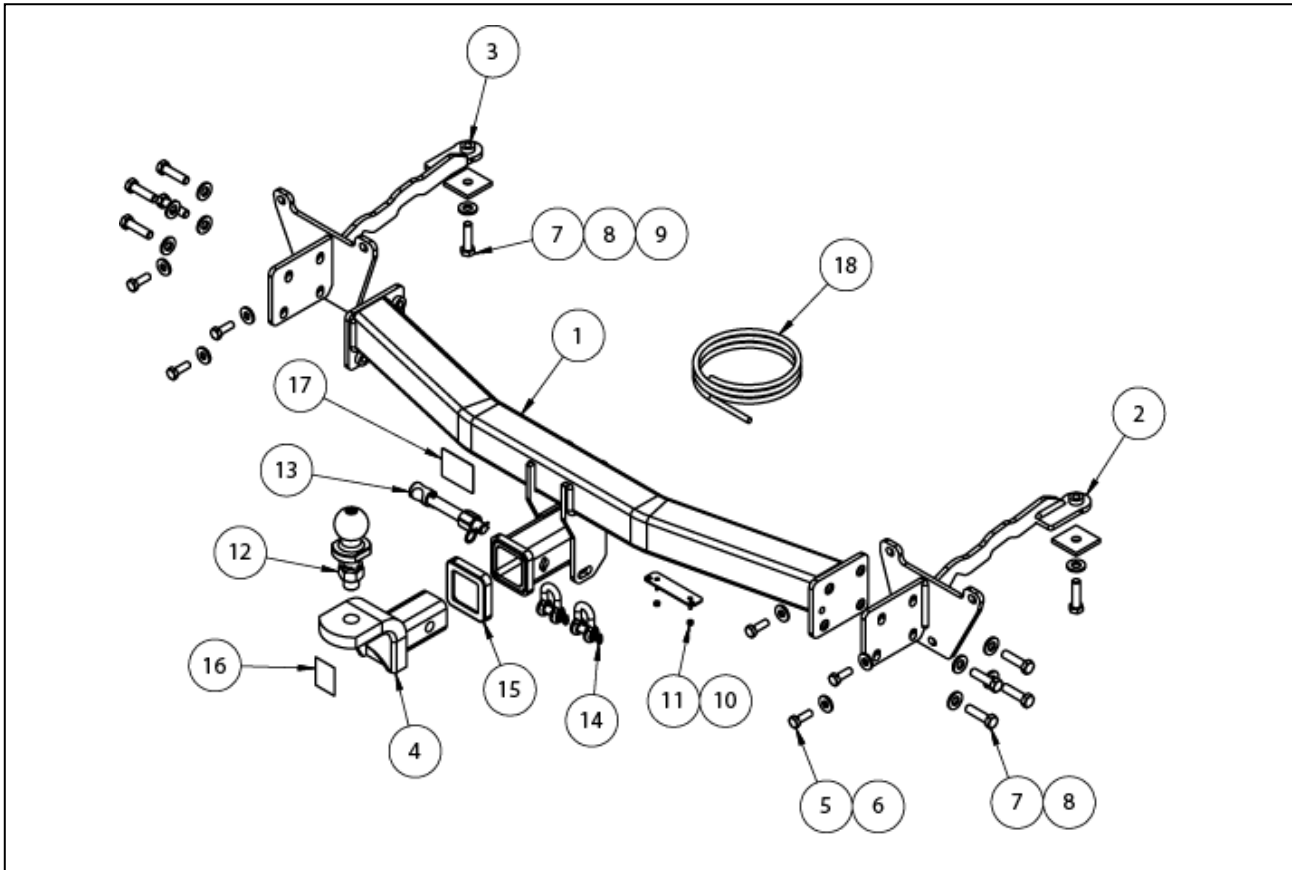

ITEM	DESCRIPTION	QTY
1	WELDED ASSEMBLY	1
2	SIDE ARM ASSEMBLY RHS	1
3	SIDE ARM ASSEMBLY LHS	1
4	TRAIL BALL MOUNT	1
5	SET SCREW M10-1.25x30 GR 8.8Z/P	6
6	WASHER FT M10 x 25.4 x 3	6
7	SET SCREW M12 x 45 x 1.25P G10.9	10
8	WASHER FLAT 1/2"x1 1/8"x1/8"	10
9	LOOSE PLATE	2

ITEM	DESCRIPTION	QTY
10	PLUG BRACKET	1
11	NUT NYLOC M4-0.7 Z/P	2
12	HR TOWBALL	1
13	ANTI-RATTLE PULL PIN ASSY GOLD	1
14	"D" SHACKLE 10 MM	2
15	HITCH BOX COLLAR COVER	1
16	H.R STICKER	1
17	ACRYLIC CP LABEL	1
18	WIRING LOOM	1

Hayman Reese (Cequent)
 PO Box 4050, Dandenong South VIC 3164
 Phone 1800 812 017 Email info@haymanreese.com.au

www.haymanreese.com.au



HAYMAN REESE
PART No: 03161RW
FIAT DOBLO 263

INSTALLATION INSTRUCTIONS

PLEASE ENSURE THAT INSTRUCTIONS ARE UNDERSTOOD PRIOR TO FITMENT
PLACE THESE INSTRUCTIONS IN THE VEHICLE'S GLOVEBOX AFTER INSTALLATION IS COMPLETED

1. Remove 4 x Screws from top of rear bumper.

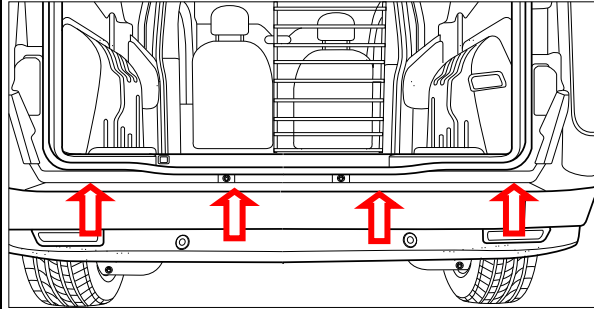

2. Remove 3 x Screws securing rear tail light assembly.

Repeat for opposite side of vehicle.

3. Remove and disconnect tail light assembly.

Repeat for opposite side of vehicle.

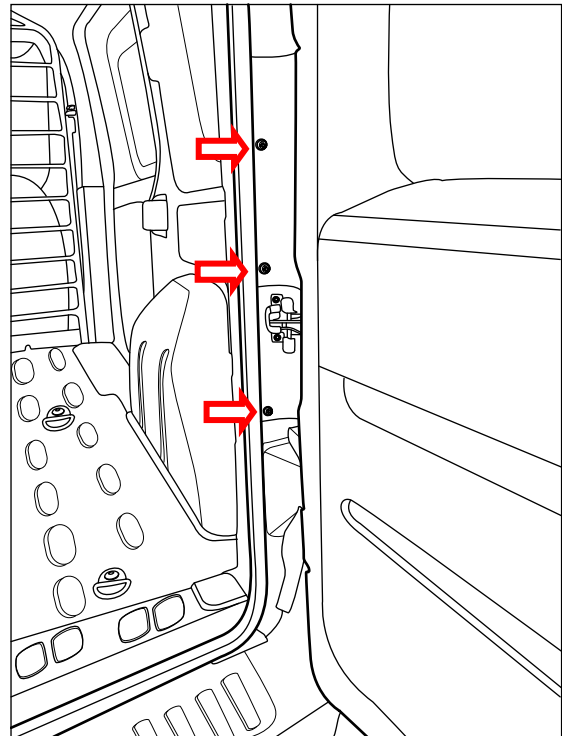

Hayman Reese (Cequent)
PO Box 4050, Dandenong South VIC 3164
Phone 1800 812 017 Email info@haymanreese.com.au

www.haymanreese.com.au



HAYMAN REESE
PART No: 03161RW
FIAT DOBLO 263

INSTALLATION INSTRUCTIONS

PLEASE ENSURE THAT INSTRUCTIONS ARE UNDERSTOOD PRIOR TO FITMENT
PLACE THESE INSTRUCTIONS IN THE VEHICLE'S GLOVEBOX AFTER INSTALLATION IS COMPLETED

4. Remove 1 x Screw at top of rear bumper, at tail light assembly cavity.

Repeat for opposite side of vehicle.

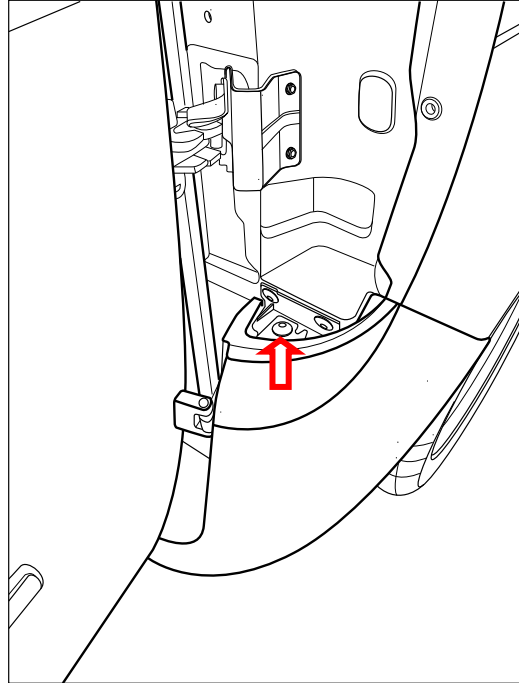

5. Remove 3 x Screws from underside of rear bumper.

6. Remove 1 x Screw from underside of rear bumper, behind rear wheel arch.

Repeat for opposite side of vehicle.

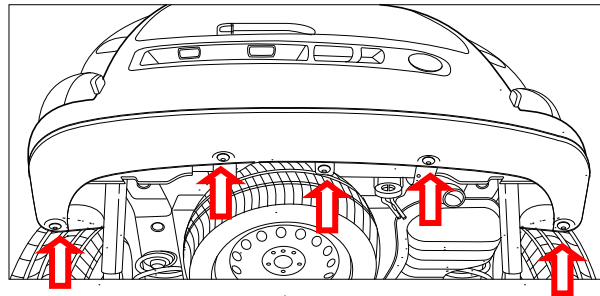

Hayman Reese (Cequent)
PO Box 4050, Dandenong South VIC 3164
Phone 1800 812 017 Email info@haymanreese.com.au

www.haymanreese.com.au



HAYMAN REESE
PART No: 03161RW
FIAT DOBLO 263

INSTALLATION INSTRUCTIONS

PLEASE ENSURE THAT INSTRUCTIONS ARE UNDERSTOOD PRIOR TO FITMENT
PLACE THESE INSTRUCTIONS IN THE VEHICLE'S GLOVEBOX AFTER INSTALLATION IS COMPLETED

7. Remove 2 x Screws from inside rear wheel arch.
 8. Remove 1 x Screw from where top of rear bumper meets rear wheel arch.
- Repeat steps 7 and 8 for opposite side of vehicle.

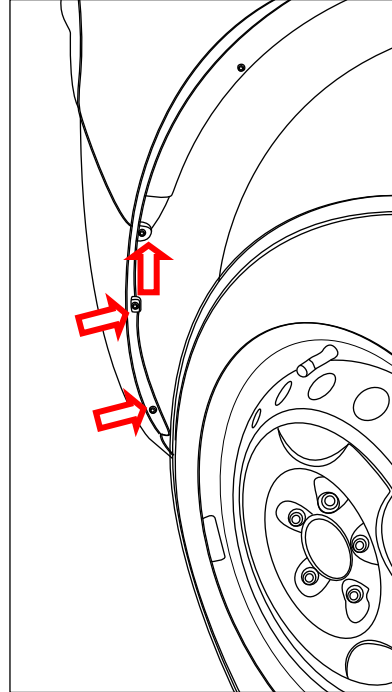

9. Lower rear muffler by disconnecting exhaust hangers.

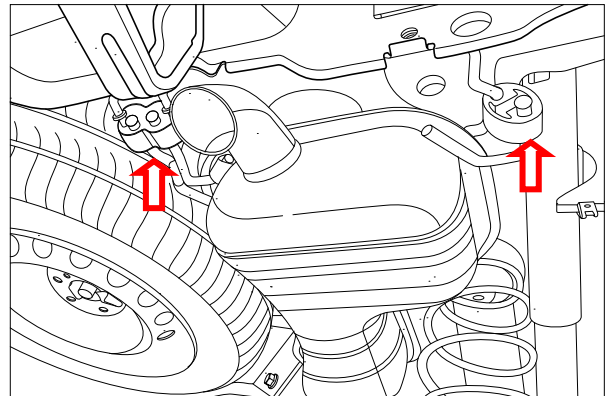

Hayman Reese (Cequent)
PO Box 4050, Dandenong South VIC 3164
Phone 1800 812 017 Email info@haymanreese.com.au

www.haymanreese.com.au



HAYMAN REESE
PART No: 03161RW
FIAT DOBLO 263

INSTALLATION INSTRUCTIONS

PLEASE ENSURE THAT INSTRUCTIONS ARE UNDERSTOOD PRIOR TO FITMENT
PLACE THESE INSTRUCTIONS IN THE VEHICLE'S GLOVEBOX AFTER INSTALLATION IS COMPLETED

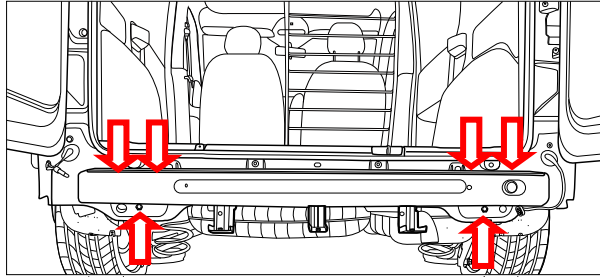
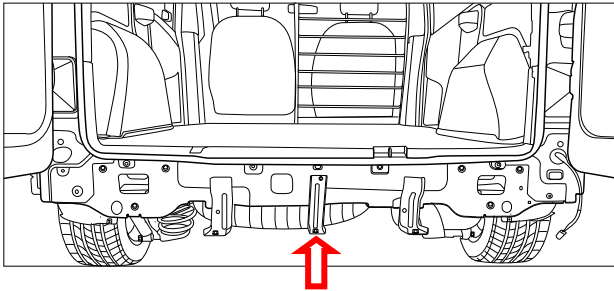
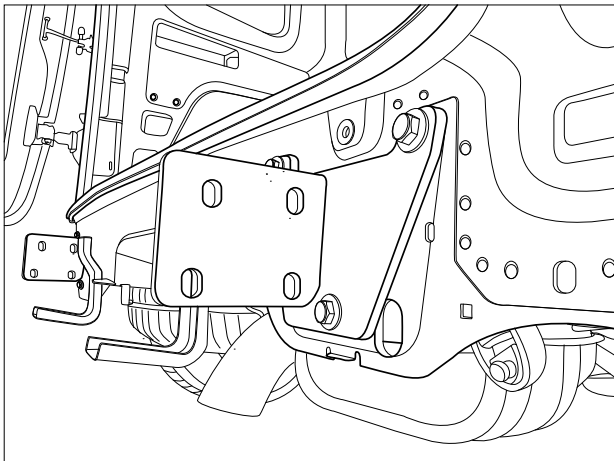
<p>10. Carefully unclip and remove rear bumper by peeling outwards, then pulling removing rearward.</p> <p>Disconnect parking sensor loom during remove, where applicable.</p> <p>11. Remove and discard 6 x hex head screws securing impact beam to rear panel of vehicle.</p> <p>Remove and discard rear impact beam.</p>	
<p>12. Remove and discard central bumper tab bracket and screw.</p>	
<p>13. Insert side arm bracket into chassis rail, and loosely secure with 3 x M10 hex head Screws, complete with 1 x M10 Washer per Screw.</p> <p>Repeat for opposite side of vehicle.</p>	

Hayman Reese (Cequent)
PO Box 4050, Dandenong South VIC 3164
Phone 1800 812 017 Email info@haymanreese.com.au

www.haymanreese.com.au



HAYMAN REESE
PART No: 03161RW
FIAT DOBLO 263

INSTALLATION INSTRUCTIONS

PLEASE ENSURE THAT INSTRUCTIONS ARE UNDERSTOOD PRIOR TO FITMENT
PLACE THESE INSTRUCTIONS IN THE VEHICLE'S GLOVEBOX AFTER INSTALLATION IS COMPLETED

14. Remove rubber grommet from underside of chassis rail.

Repeat for opposite side of vehicle.

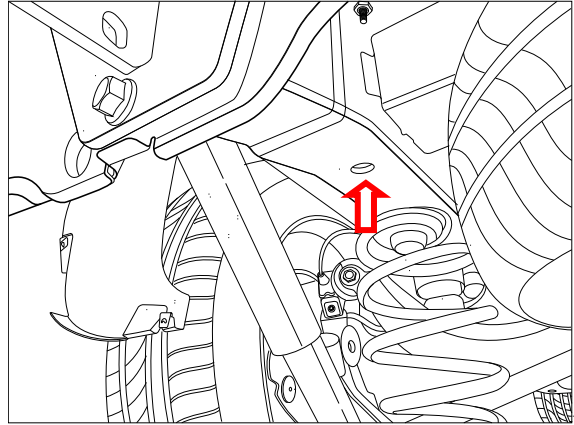

15. Loosely secure side arm bracket to underside of chassis rail using 1 x M12 Hex head Screw, complete with 1 x M12 Washer and 1 x 50mm x 50mm loose plate.

Repeat for opposite side of vehicle.

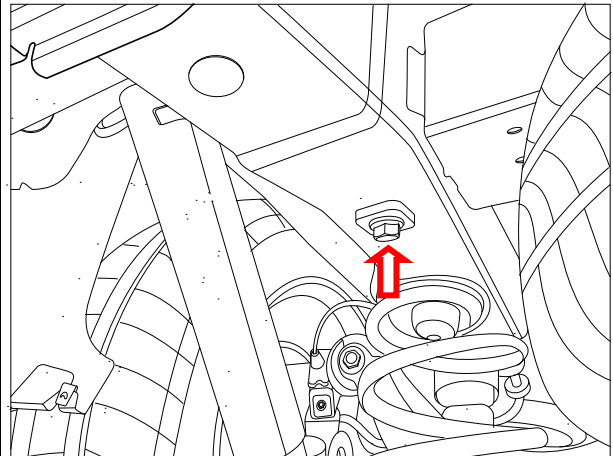

Hayman Reese (Cequent)
PO Box 4050, Dandenong South VIC 3164
Phone 1800 812 017 Email info@haymanreese.com.au

www.haymanreese.com.au



HAYMAN REESE
PART No: 03161RW
FIAT DOBLO 263

INSTALLATION INSTRUCTIONS

PLEASE ENSURE THAT INSTRUCTIONS ARE UNDERSTOOD PRIOR TO FITMENT
PLACE THESE INSTRUCTIONS IN THE VEHICLE'S GLOVEBOX AFTER INSTALLATION IS COMPLETED

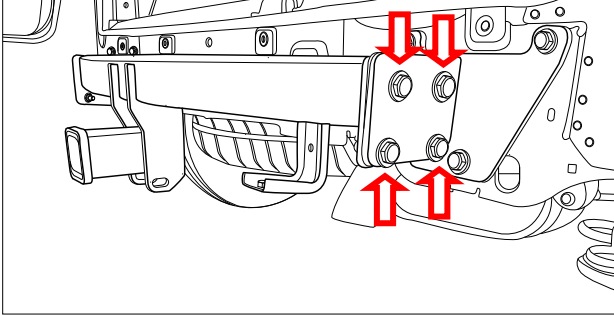
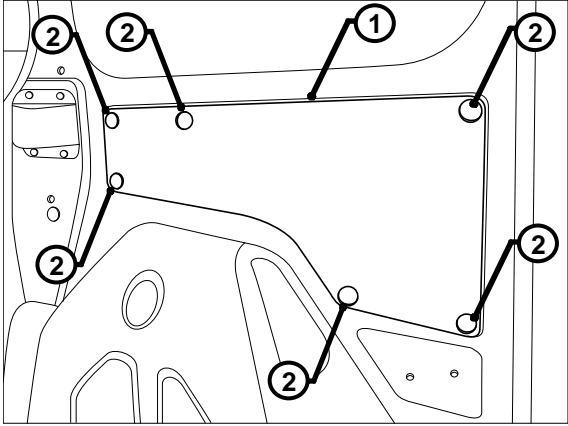
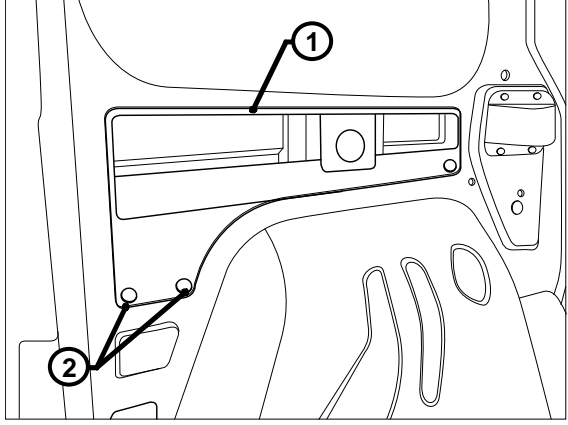
<p>16. Offer Towbar to side arm brackets and loosely secure using 8 x M12 hex head Screws (4 per side), complete with 1 x M12 Flat washer per Screw.</p> <p>17. Tighten all fasteners to torques listed below:</p> <p>M10: 48N.m M12: 125N.m</p>	
<p>18. Inside the rear cargo hold, remove the cargo hold RHS trim (1) by removing the six clips (2).</p>	
<p>19. Remove the LHS trim (1) by removing the two clips (2) and undoing the trim clipping points. Take caution when removing trim to avoid damage as this trim can be difficult to remove.</p>	

Hayman Reese (Cequent)
PO Box 4050, Dandenong South VIC 3164
Phone 1800 812 017 Email info@haymanreese.com.au

www.haymanreese.com.au



HAYMAN REESE
PART No: 03161RW
FIAT DOBLO 263

INSTALLATION INSTRUCTIONS

PLEASE ENSURE THAT INSTRUCTIONS ARE UNDERSTOOD PRIOR TO FITMENT
PLACE THESE INSTRUCTIONS IN THE VEHICLE'S GLOVEBOX AFTER INSTALLATION IS COMPLETED

20. On the LHS rear quarter exterior, remove the vent (1) by the wheel arch and remove the grommet (2) from inside.
Repeat for the RHS vent and grommet.

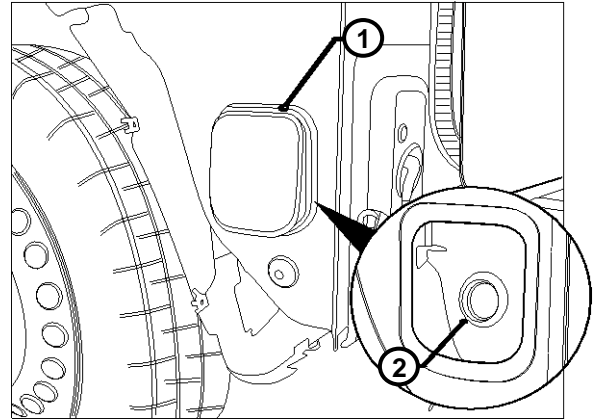

21. On the RHS rear quarter exterior, drill a Ø30mm hole (1) above the vent in the specified location.
Ensure the area being drilled into is clear of all obstructions before drilling. After drilling, file down any rough edges and apply rust inhibitor (not supplied).

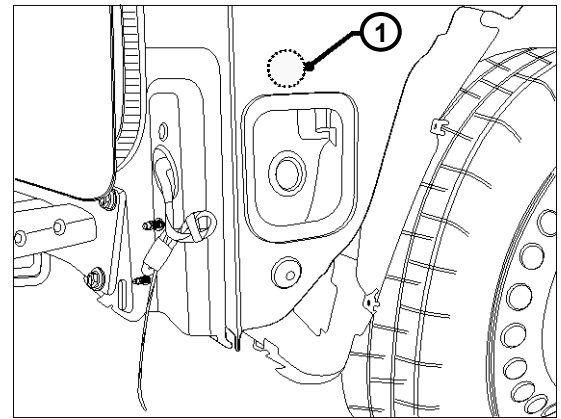

22. Route the trailer patch (P/No: 101416-WL) (1), starting from the interior RHS cavity, down to the RHS Ø40mm grommet (2) across the top of the towbar and then underneath the vehicle and out of the LHS Ø40mm grommet hole (3).
Refer to the harness labels for routing orientation.

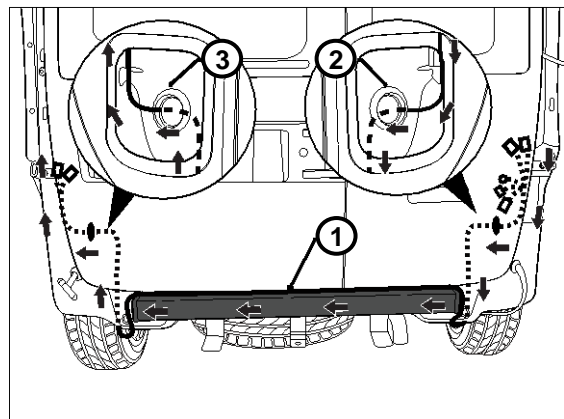

Hayman Reese (Cequent)
PO Box 4050, Dandenong South VIC 3164
Phone 1800 812 017 Email info@haymanreese.com.au

www.haymanreese.com.au



HAYMAN REESE
PART No: 03161RW
FIAT DOBLO 263

INSTALLATION INSTRUCTIONS

PLEASE ENSURE THAT INSTRUCTIONS ARE UNDERSTOOD PRIOR TO FITMENT
PLACE THESE INSTRUCTIONS IN THE VEHICLE'S GLOVEBOX AFTER INSTALLATION IS COMPLETED

23. Inside the cargo hold, retrieve the vehicle tail light harness (1) into the trim cavity and then connect the trailer patch harness RHS mating connector (2). Route the other tail light connector (3) out of the tail light (3) cavity.

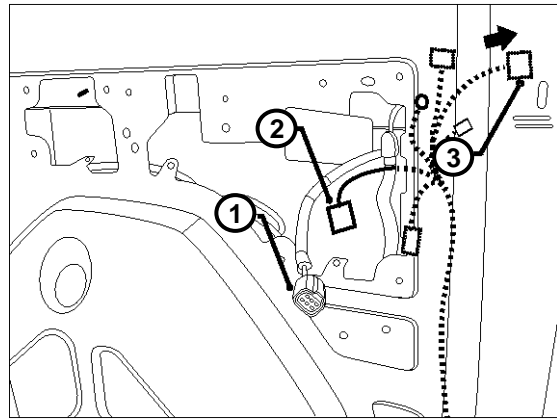

24. Secure the trailer patch ground ring terminal (1) to the vehicle grounding point (2).

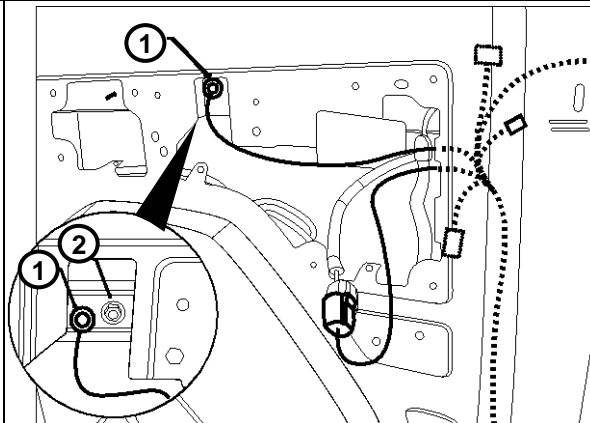

25. Connect the trailer patch ECU connector (1) to the ECU (P/No: 04826) (2).

26. Inside the RHS trim cavity, locate a suitable area on the sheet metal (3) to mount the ECU (2). Clean the chosen location using an alcohol wipe (not supplied) and then mount the ECU (2) into place.

Note: Ensure ECU is mounted with the connector facing downwards.

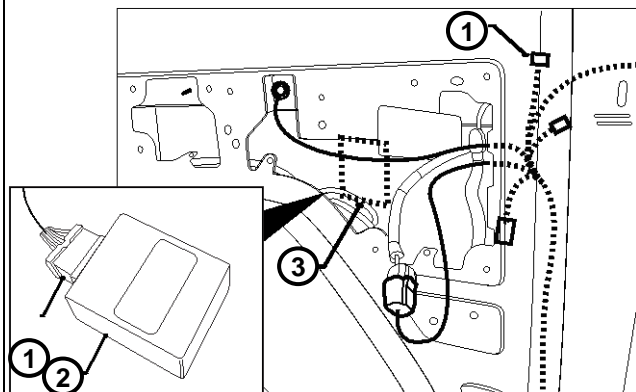

Hayman Reese (Cequent)
PO Box 4050, Dandenong South VIC 3164
Phone 1800 812 017 Email info@haymanreese.com.au

www.haymanreese.com.au



HAYMAN REESE
PART No: 03161RW
FIAT DOBLO 263

INSTALLATION INSTRUCTIONS

PLEASE ENSURE THAT INSTRUCTIONS ARE UNDERSTOOD PRIOR TO FITMENT
PLACE THESE INSTRUCTIONS IN THE VEHICLE'S GLOVEBOX AFTER INSTALLATION IS COMPLETED

27. At the rear exterior of the vehicle, mount the tail harness socket (1) to the towbar mounting bracket using M4 fasteners.

28. Route the tail harness (tail length: 1800mm) (2) across the RHS and up into the drilled out hole (3). Adjust the trailer patch harness grommet so that it is seated correctly. **Do not seal or tie off the tail harness grommet yet.**

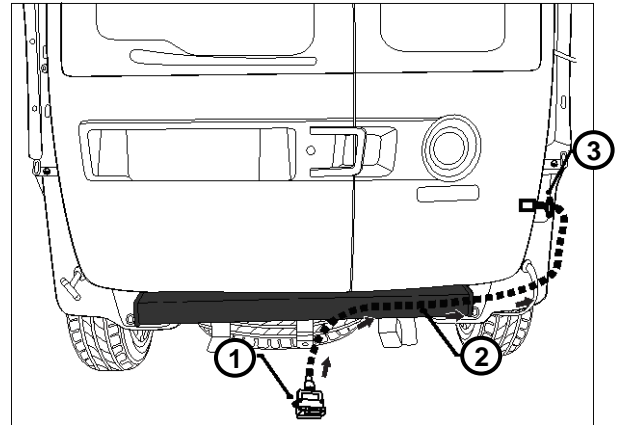

29. Connect the tail harness (tail length 1800mm) 8-way connector (1) to the trailer patch mating 8-way connector (2).

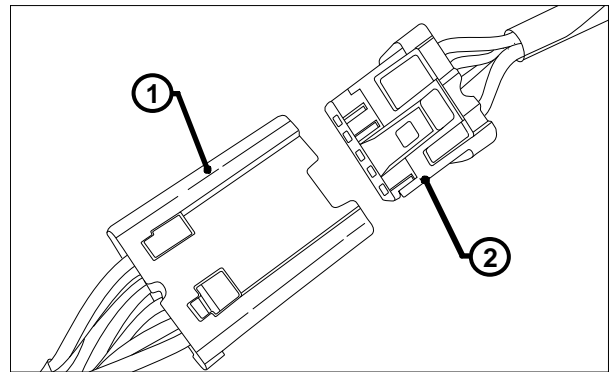

30. In the engine bay battery area, route the power harness (P/No: 04825) (1) from the battery area, down to the LHS chassis rail.
Do not connect the harness ring terminal to the battery yet. Ensure to route harness away from sharp edges, moving parts or sources of extreme heat.

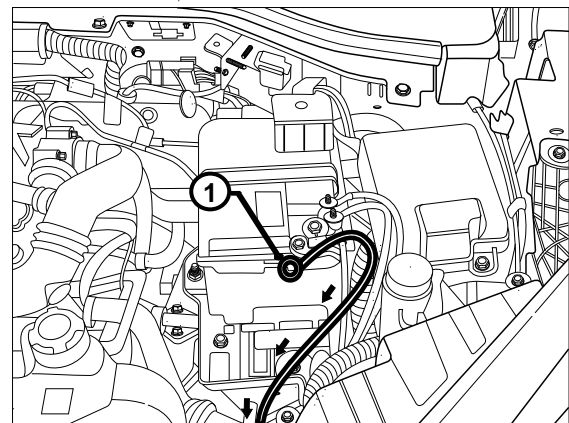

Hayman Reese (Cequent)
PO Box 4050, Dandenong South VIC 3164
Phone 1800 812 017 Email info@haymanreese.com.au

www.haymanreese.com.au



HAYMAN REESE
PART No: 03161RW
FIAT DOBLO 263

INSTALLATION INSTRUCTIONS

PLEASE ENSURE THAT INSTRUCTIONS ARE UNDERSTOOD PRIOR TO FITMENT
PLACE THESE INSTRUCTIONS IN THE VEHICLE'S GLOVEBOX AFTER INSTALLATION IS COMPLETED

31. Route the power harness (1) along the LHS chassis rail, towards the rear of the vehicle.
Ensure to route harness away from sharp edges, moving parts or sources of extreme heat.

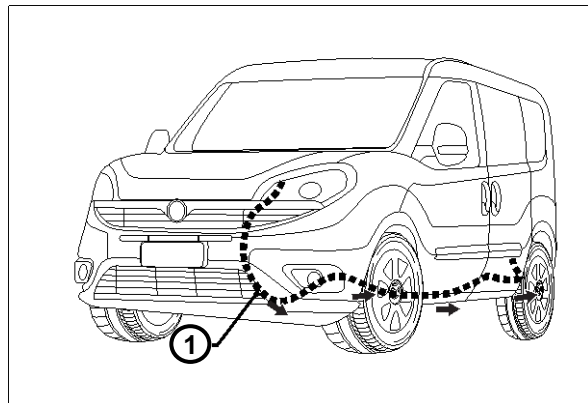

32. Route the power harness (1) along the top of the towbar and into the tail harness grommet (2).
Ensure to route harness away from sharp edges, moving parts or sources of extreme heat.

33. Connect the power harness 1-way connector (3) to the trailer patch mating 1-way connector (4).
Seal off the tail harness grommet (2) using a cable tie (not supplied).

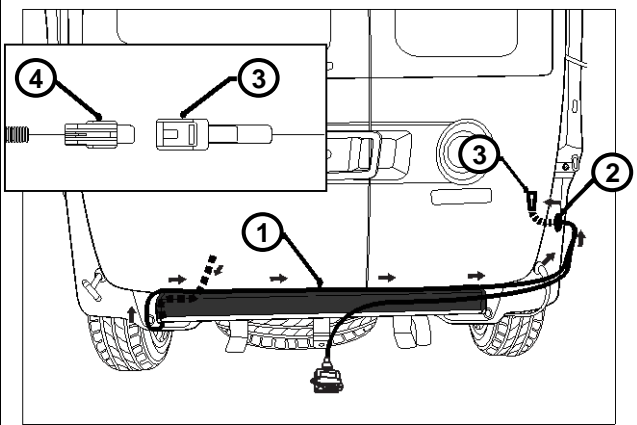

34. Connect the trailer patch tail light connectors to the tail light assemblies. Refit the tail light assemblies.

In the engine bay, connect the power harness ring terminal (1) to the battery positive terminal (2).

36. Test the trailer patch function using a light board or multi-meter.
37. Secure all harnesses using cable ties (not supplied).
38. Re-fit all removed trim parts and secure all fasteners, ensuring there are no squeaks or rattles.

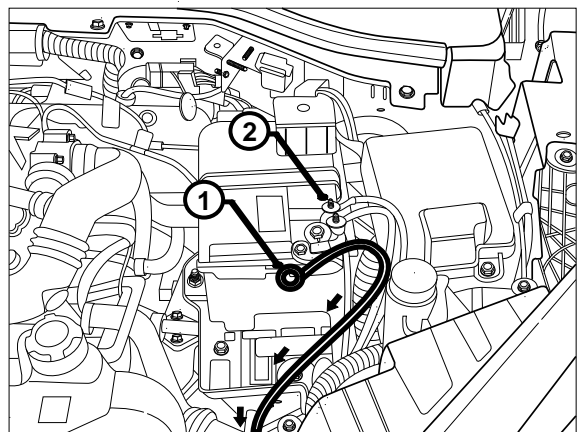

Hayman Reese (Cequent)
PO Box 4050, Dandenong South VIC 3164
Phone 1800 812 017 Email info@haymanreese.com.au

www.haymanreese.com.au



HAYMAN REESE
PART No: 03161RW
FIAT DOBLO 263

INSTALLATION INSTRUCTIONS

PLEASE ENSURE THAT INSTRUCTIONS ARE UNDERSTOOD PRIOR TO FITMENT
PLACE THESE INSTRUCTIONS IN THE VEHICLE'S GLOVEBOX AFTER INSTALLATION IS COMPLETED

39. Create bumper cut 90mm wide x 150mm long, starting at corner of bumper lip.

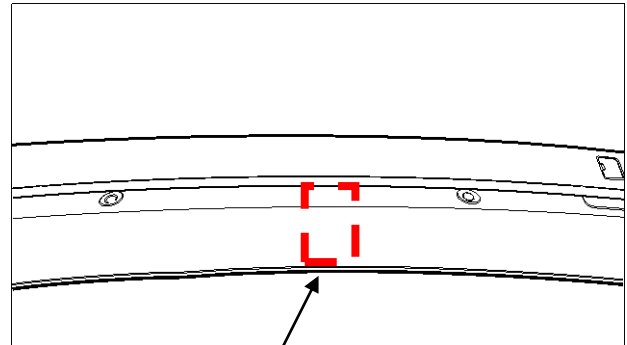

Bottom lip of bumper

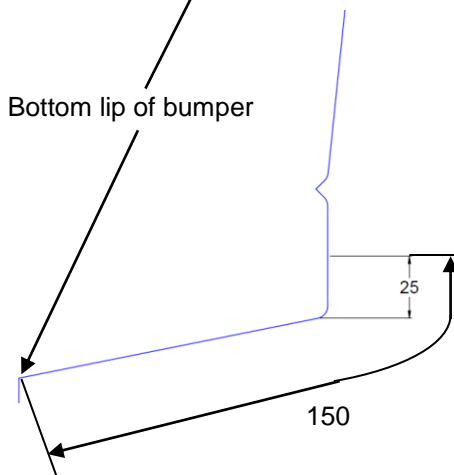

Hayman Reese (Cequent)
PO Box 4050, Dandenong South VIC 3164
Phone 1800 812 017 Email info@haymanreese.com.au

www.haymanreese.com.au



HAYMAN REESE
PART No: 03161RW
FIAT DOBLO 263

INSTALLATION INSTRUCTIONS

PLEASE ENSURE THAT INSTRUCTIONS ARE UNDERSTOOD PRIOR TO FITMENT
PLACE THESE INSTRUCTIONS IN THE VEHICLE'S GLOVEBOX AFTER INSTALLATION IS COMPLETED

40. Mark out and drill 2x ø5mm holes 69mm apart on bumper skin to support plug bracket. Feed bracket threads through drilled holes prior to reinstalling bumper.

41. Reinstall bumper following steps 1 to 10 in reverse order.

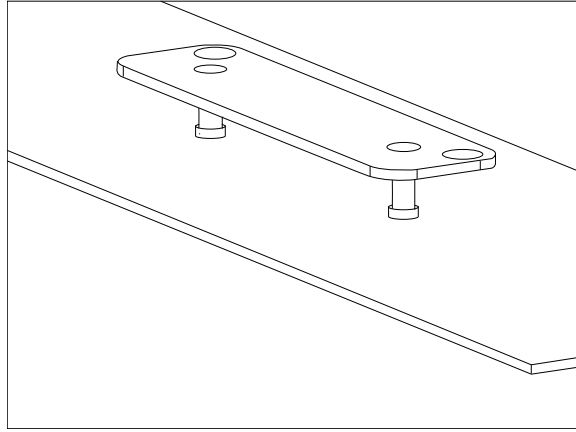

Hayman Reese (Cequent)
PO Box 4050, Dandenong South VIC 3164
Phone 1800 812 017 Email info@haymanreese.com.au

www.haymanreese.com.au

