



TOWBAR INSTALLATION INSTRUCTIONS

PART NUMBER 03286RW

BMW X3 G01 & X4 G02 CL4



PRODUCT DETAILS:

Part Number:	03286RW	Maximum Towing Braked:	2000	kg
ECU Number:	WLE70011	Maximum Towing Unbraked:	750	kg
Tail Harness Length Required:	1200 mm	Maximum Static Ball Load:	100	kg
TBM/Lug Part Number:	21148			
Wiring Part Number:	WLL90011			

FITTING DETAILS:

Towbar Installation Time:	145 Mins.	Vehicle Coding Required:	NO
Wiring Installation Time:	60 Mins.	RPA Disable/Other:	YES
Total Installation Time:	205 Mins.	Note:	
Bumper Cut Required:	Yes		<ul style="list-style-type: none">Electric Brake = Brake Prep Connector



TOWBAR INSTALLATION INSTRUCTIONS

PART NUMBER 03286RW

BMW X3 G01 & X4 G02 CL4

ENSURE THAT INSTRUCTIONS ARE UNDERSTOOD PRIOR TO FITMENT.

i BEFORE YOU START:

Hayman Reese recommends that instructions are read completely prior to fitment. Check all hardware items have been included refer to assembly diagram. Please ensure this towbar is only fitted to vehicle models as per Hayman Reese application guide (www.haymanreese.com.au).

Bumper Cuts



Vehicle and bumper variations can and do occur during vehicle manufacture after initial towbar design. Fitment of towbar to vehicle and accuracy of bumper cut must be assessed prior to any bumper modifications made. Incorrect bumper cuts are not covered under Hayman Reese warranty.

NOTE: Bumper cuts need to be approached with care, refer to notes below.

- Bumper centreline – where the centreline of the bumper needs to be determined, the installer must assess centre point by measurement of bumper width or determining two symmetrical reference points to give centreline.
- Bumper edge – To assist with accurate bumper cut measurement, reference to the start of the bumper edge is now being commonly used.
 - Measure from bottom edge along bumper and around corner to the 70 mm point (Figure 1).
 - Do not measure from visible bumper front of corner, upwards (Figure 2).

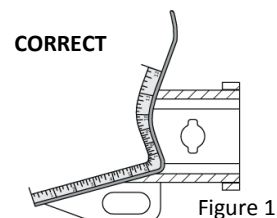

Figure 1

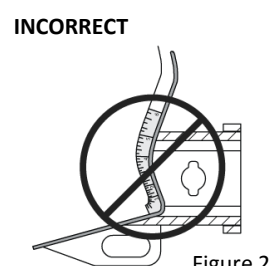

Figure 2

Drilling

- For any required drilling during installation, ensure that the area is clear of fuel, electrical & other components that may be damaged.
- All holes drilled into the body panels shall have all burrs & swarf removed then coated with a suitable rust preventative paint.

Bolts/Fasteners

- Ensure that all hardware is fastened to correct torque as specified in this fitting instruction.
- All fasteners supplied with this product are used to achieve a specified clamp loading. If replacement is required ensure that fasteners of the same grade and class are used.



NOTE: Achieving correct torque is critical to proper installation and responsibility of the installer. Towbar failures attributed to tension issues from over tightening or under tightening are not covered by Hayman Reese warranty.

Product Labels

- a. Towbar load rating sticker provided with this product shall be conspicuously located on inside rear end of the driver's door.
- b. Powertrain Control Module (PCM)/Body Control Module (BCM) upgrade warning label will be provided in towbar kit for vehicles as required. Affix warning label in door and owner's handbook.

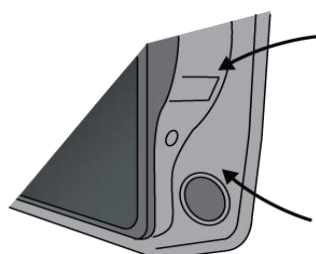

Place **Load Rating sticker** inside driver's door here

Place **Vehicle PCM/ BCM upgrade warning label** in door AND on front cover of owner's service handbook

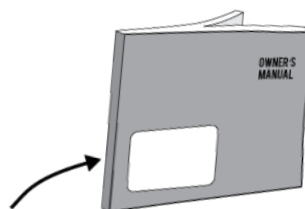

WARNING:

Do not, drill, cut, weld or otherwise modify the towbar.

FOR TOWING PURPOSES ONLY - This towbar is designed and tested by Hayman Reese to adhere to ADR 62/02 which provides only for the expected load demands of towing.



TOWBAR INSTALLATION INSTRUCTIONS

PART NUMBER 03286RW

BMW X3 G01 & X4 G02 CL4

i TOWBAR ASSEMBLY DIAGRAM

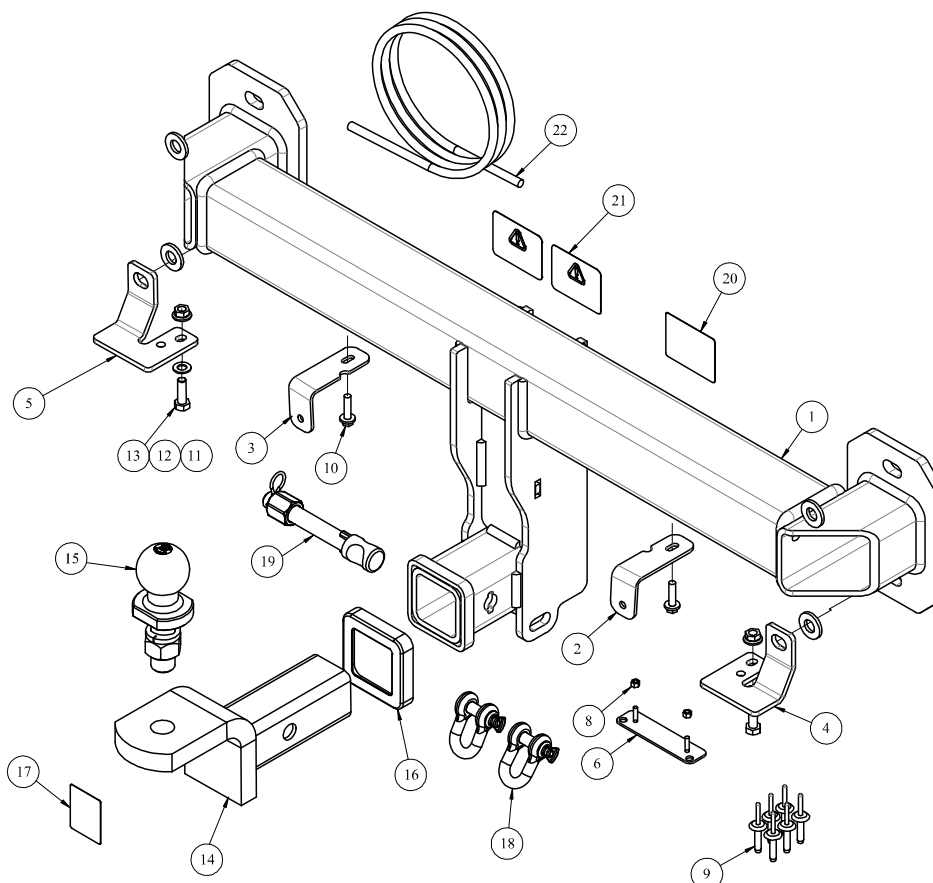

ITEM	DESCRIPTION	QTY
1	BMW X3 & X4 TOWBAR	1
2	BUMPER TAB RHS	1
3	BUMPER TAB LHS	1
4	EXHAUST BRACKET RHS	1
5	EXHAUST BRACKET LHS	1
6	VE PLUG BRACKET	1
7	WASHER PLAIN 1/2X1-1/8X16G	4
8	NUT NYLON LOCK HEX HD M4X0.7P G8	2
9	POP RIVET	6
10	TEK SCREW 14-20 HEX HD 22mm	2
11	NUT HEX FLANGED M8 X 1.25P	2

ITEM	DESCRIPTION	QTY
12	WASHER FLAT M8 x 17 x 1.20P	2
13	SETSCREW M8 x 25 Gr 8.8	2
14	TRAILER BALL MOUNT	1
15	HR TOWBALL	1
16	HITCH BOX COLLAR COVER	1
17	H.R STICKER	1
18	10mm "D" SHACKLE	2
19	ANTI-RATTLE PULL PIN ASSY GOLD	1
20	ACRYLIC COMPLIANCE LABEL	1
21	CAN TRAILER WARNING LABEL	2
22	WIRING LOOM	1



TOWBAR INSTALLATION INSTRUCTIONS

PART NUMBER 03286RW

BMW X3 G01 & X4 G02 CL4



WIRING ASSEMBLY DIAGRAM

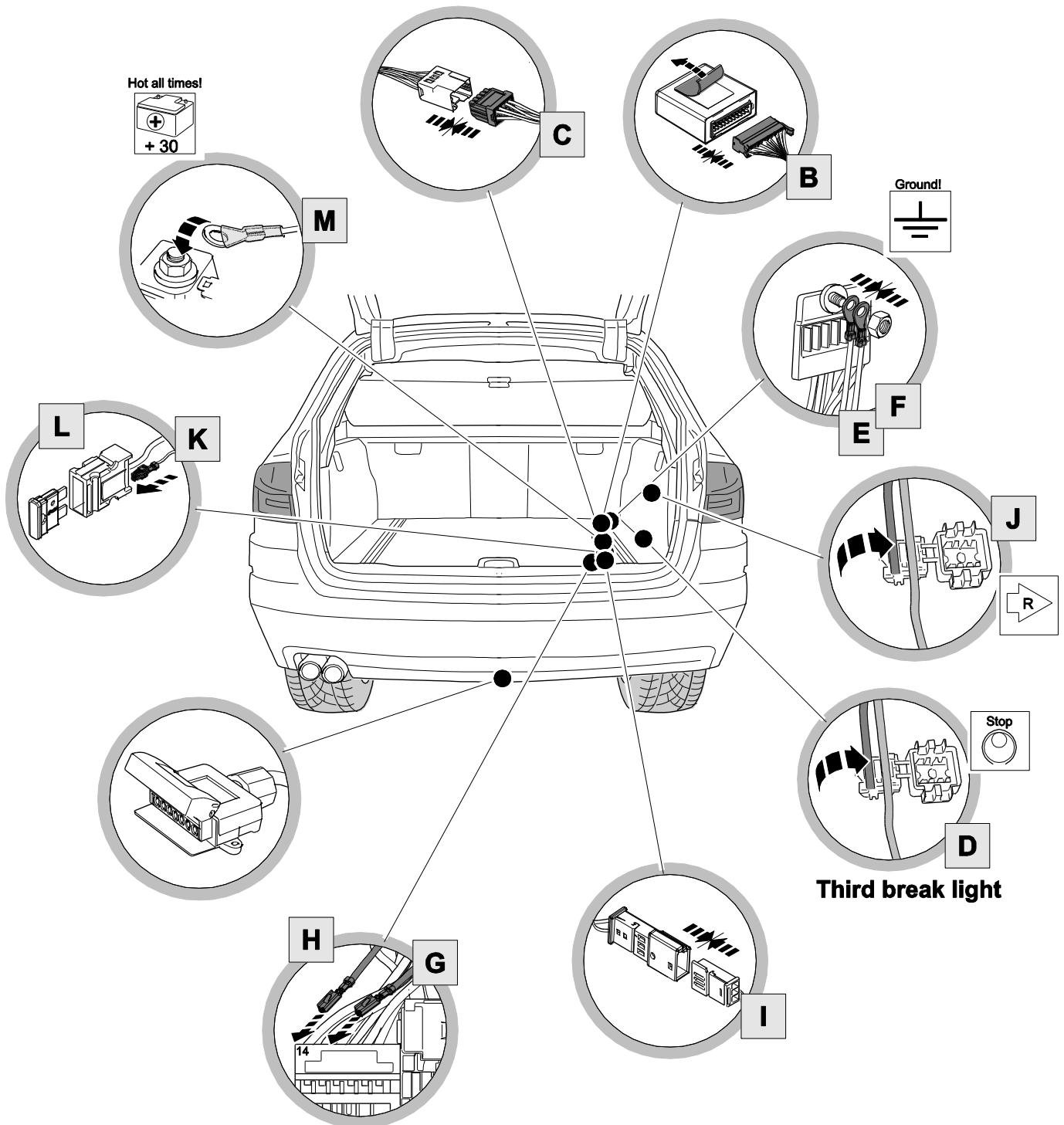



TOWBAR INSTALLATION INSTRUCTIONS

PART NUMBER 03286RW

BMW X3 G01 & X4 G02 CL4

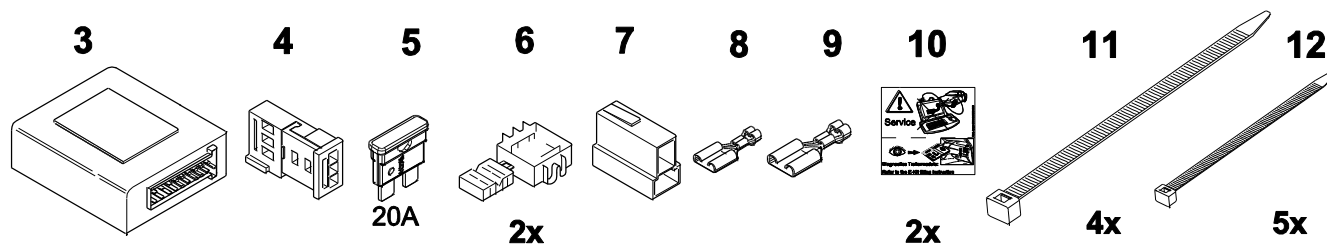
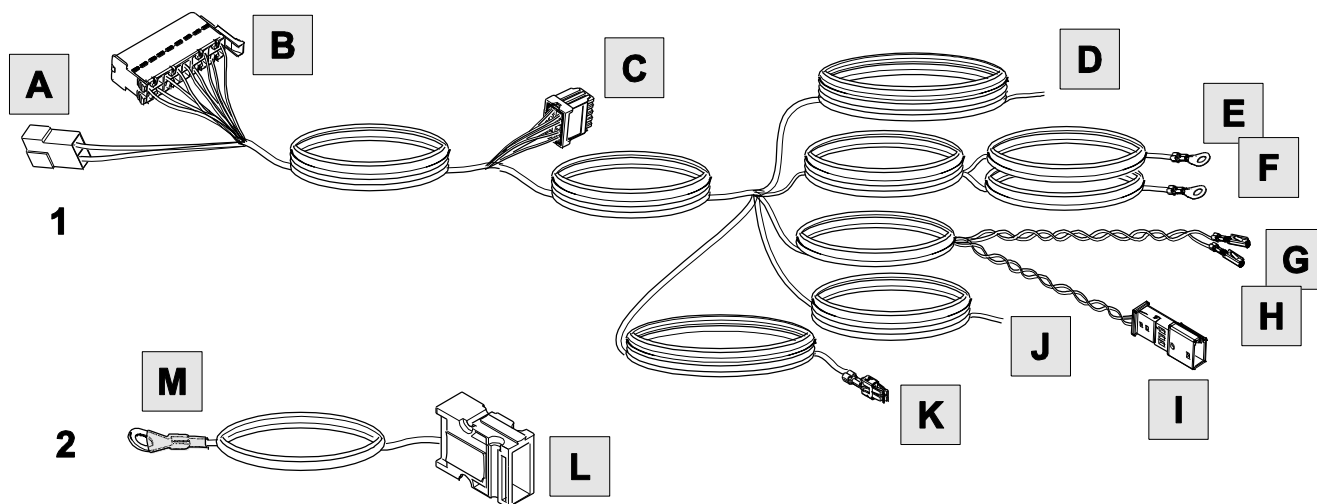

ITEM	DESCRIPTION	QTY
1	Main Harness	1
2	Fuse line	1
3	Trailer module → WLE70011	1
4	CAN 3-pin housing	1
5	20amp fuse	1
6	Wire Tap	2
7	Brake controller 2-pin housing	1
8	Brake controller plug pin - small	1
9	Brake controller plug pin - large	1
10	Label Diagnostics CAN-Module	2
11	Tie straps 300mm	4
12	Tie straps 150mm	5

Tools

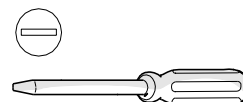
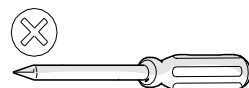
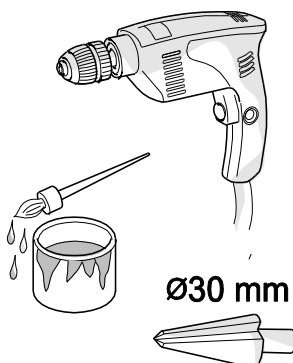
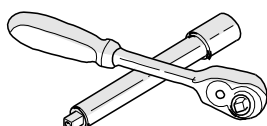
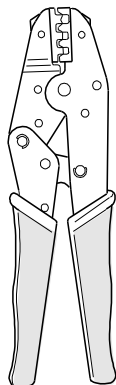

1. Open tail gate and remove the LH and RH side covers in the luggage compartment.

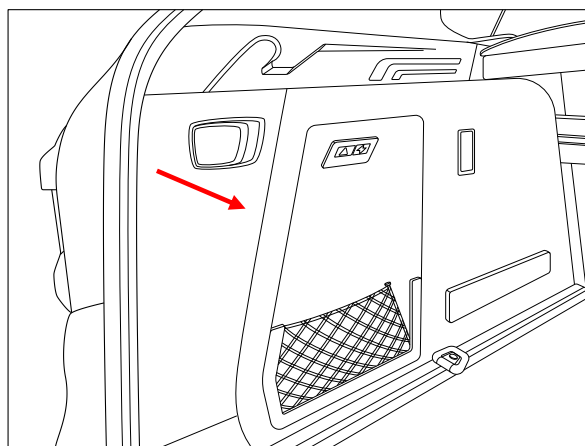

2. On the LH side, unclip and remove the safety triangle container.

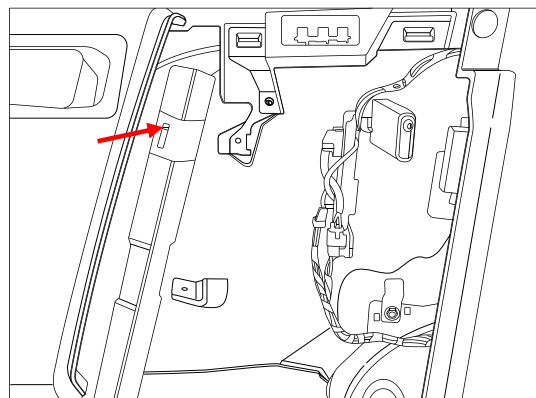

-
3. Remove plastic grommet and unclip cover from the water channel.

Repeat for opposite side.

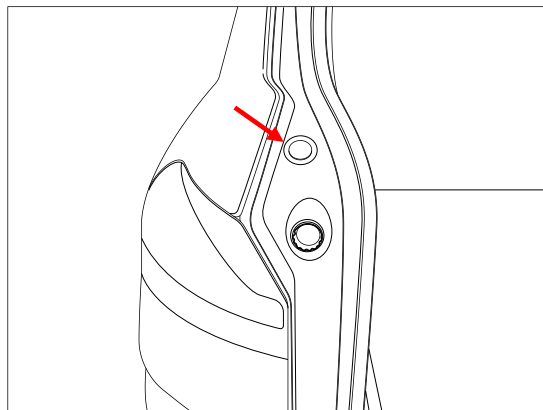

-
4. Remove 2 x screws securing interior side panel and remove panel.

Repeat for opposite side.

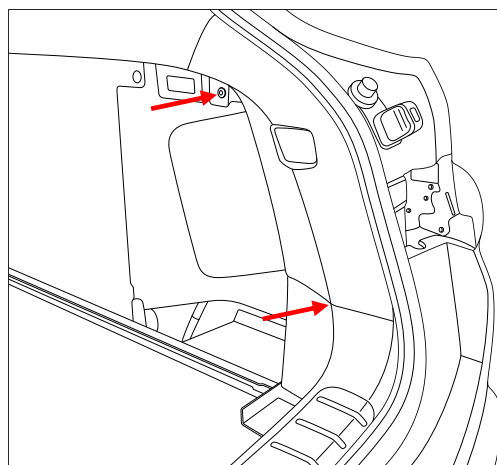

-
5. Remove the 2 x plastic grommets.
 6. Remove the 2 x nuts exposed within.

Repeat for opposite side.

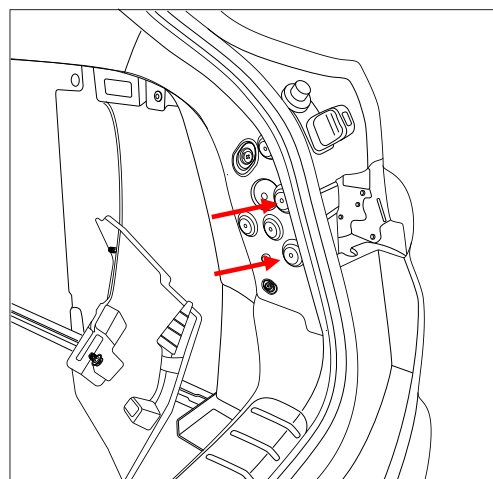



TOWBAR INSTALLATION INSTRUCTIONS

PART NUMBER 03286RW

BMW X3 G01 & X4 G02 CL4

-
7. Remove the exposed 2 x nuts securing the taillight.

Repeat for opposite side.

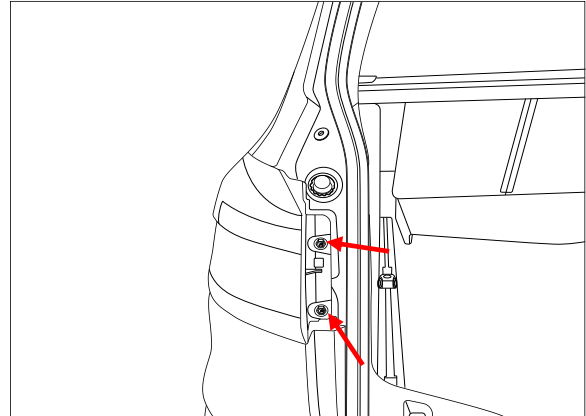

-
8. In the luggage compartment, remove 1 x nut securing the side of the tail light.
 9. Remove tail light rearwards and disconnect from wiring harness.

Repeat for opposite side.

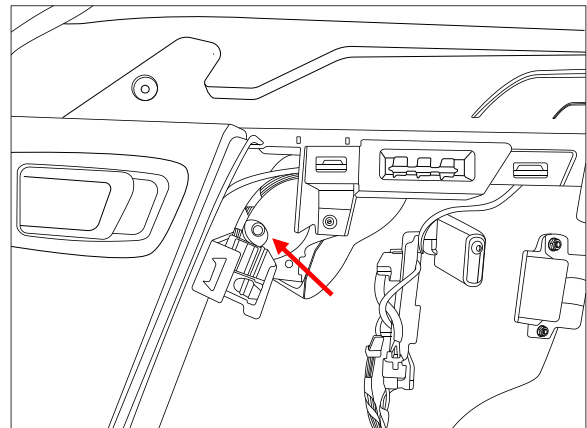

-
10. Remove reflector from bumper (push plastic tool from the side to release clip). Disconnect any plug connections.

Repeat for opposite side.

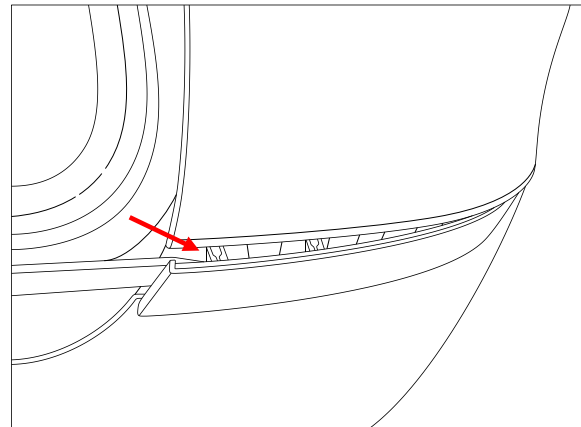

-
11. Remove 2 x screws located on the bumper in the reflector cavity.

Repeat for opposite side.

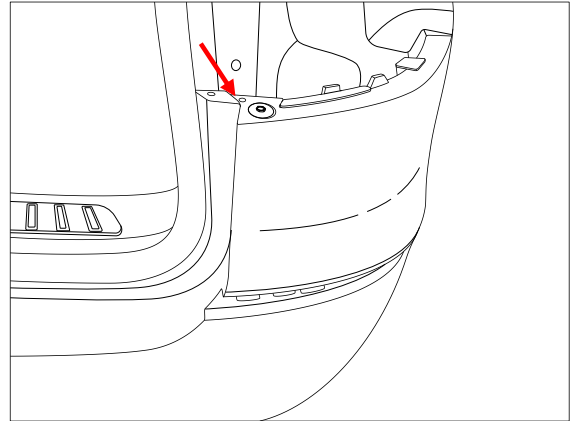

-
12. Remove 8 x screws from the bottom edge of the bumper.

13. Remove the underside protector secured with 10 x screws.

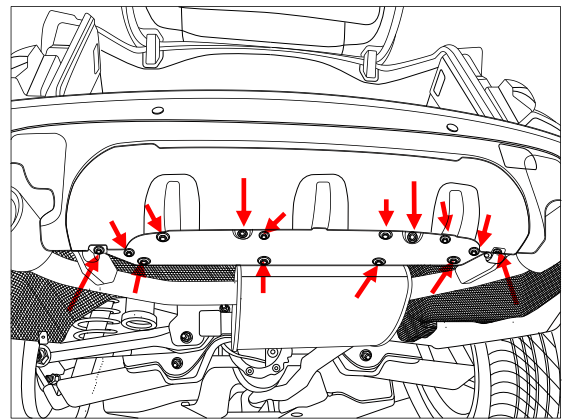

-
14. In wheel arch remove (cut off) the 3 x plastic rivets.

Repeat for opposite side.

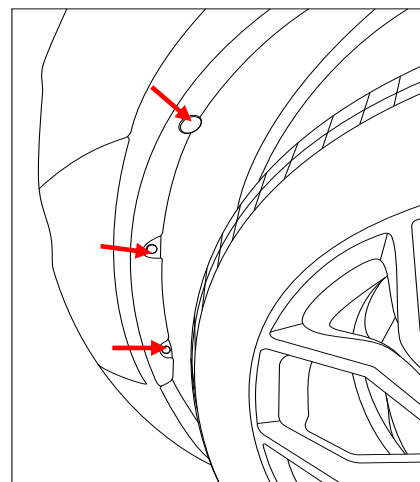

-
15. Peel away wheel arch trim to expose 2 x screws.
Remove the screws.

Repeat for opposite side.

16. Peel the bumper away from the sides and remove.

Ensure to disconnect any plug connections
located on the RH side.

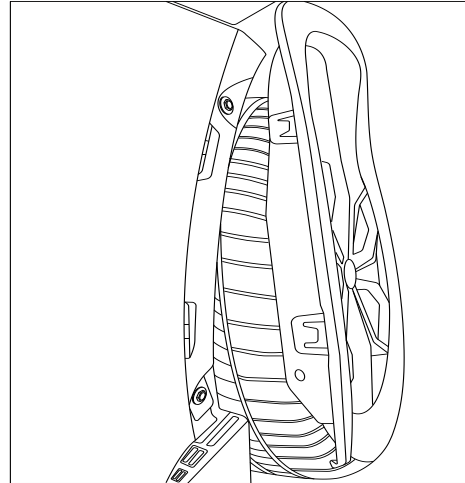

-
17. Remove the plastic sensor holder from the
impact beam secured with 6 x scrivenets.

Ensure to disconnect the centre plug connection
and supporting clip located on the RH side.

Repeat for opposite side.

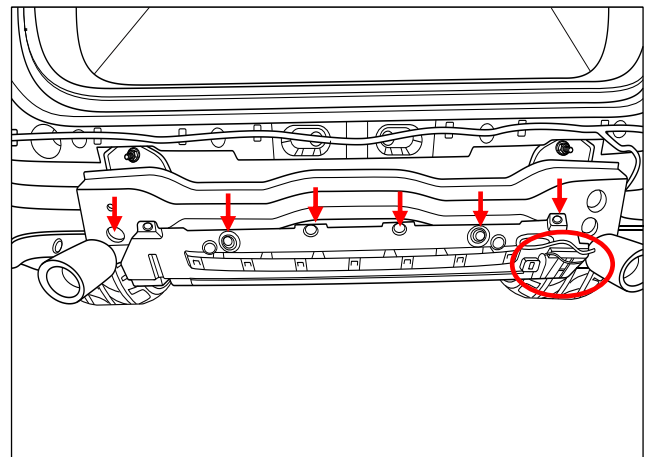

-
18. Remove the exhaust hanger bracket from the
impact beam secured with 1 x nut.

Repeat for opposite side.

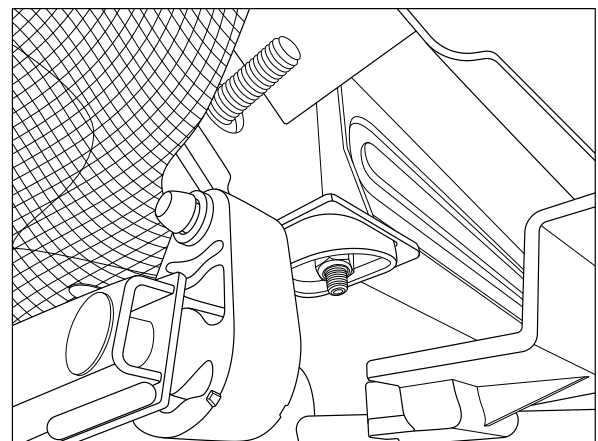



TOWBAR INSTALLATION INSTRUCTIONS

PART NUMBER 03286RW

BMW X3 G01 & X4 G02 CL4

19. Remove and discard impact beam secured with 2 x M12 nuts per side.

Retain the nuts for towbar installation.

Ensure the water ingress seal behind the impact beam remains intact and on the vehicle.

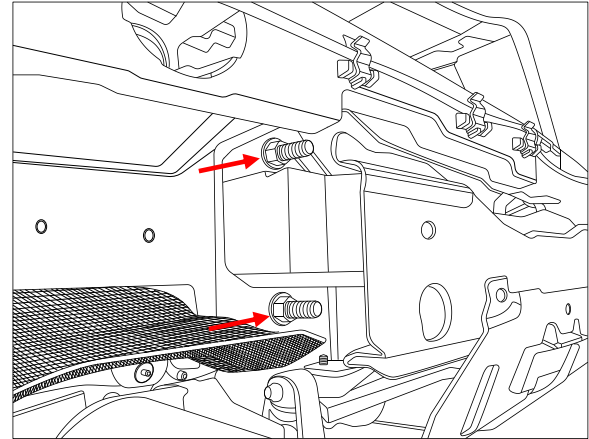

20. Secure the exhaust hanger bracket to the exhaust hanger plate with 1 x M8 bolt complete with 1 x washer and 1 x flange nut.

Torque fastener to 22Nm.

Repeat for opposite side.

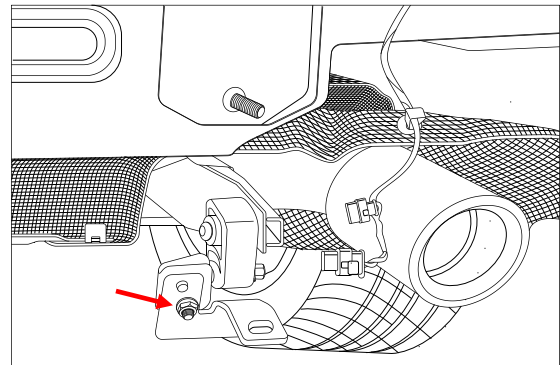

21. Position towbar onto vehicle and loosely secure the top mounting studs (LH and RH side) with 1 x M12 Nut (removed step 19) complete with 1 x M12 washer.

22. Position the exhaust hanger bracket assembly (LH and RH side) onto the bottom mounting stud and loosely secure with 1 x M12 Nut (retained) complete with 1 x M12 washer.

Torque all M12 Nuts to 108Nm

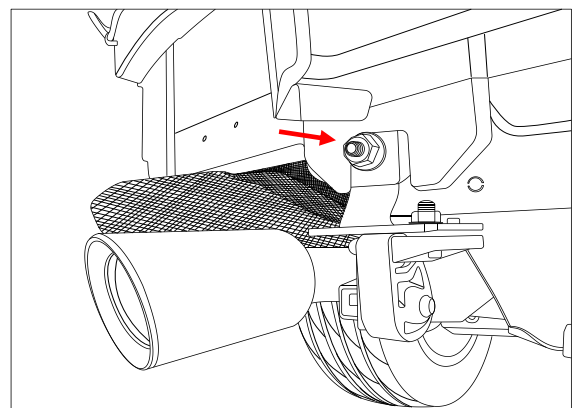

23. Secure 2 x bumper tabs onto the inside of the wiring sensor holder (removed step 13) with 2 x scrivenets (retained).

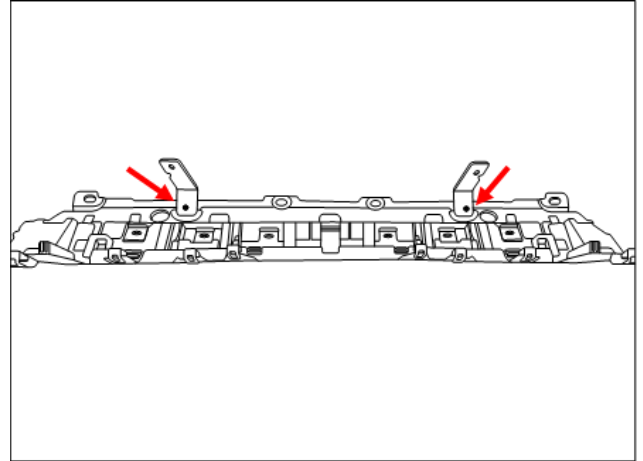

24. Refit the wiring sensor holder to the bumper and secure with 4 x Screws.

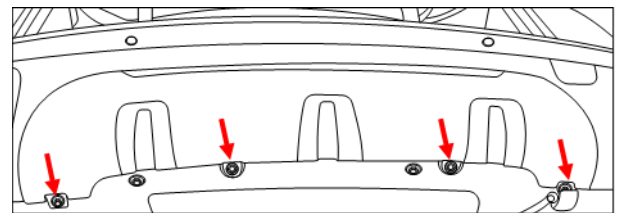

25. Refit the bumper ensuring to reconnect the centre plug connection and supporting clip of the sensor holder removed in step 16.

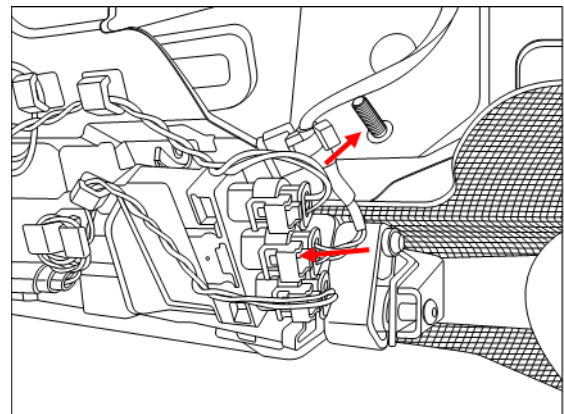

26. With the bumper in position secure the LHS and RHS Bumper tabs to the crosstube with 2 x tek screws (1 per bumper tab).

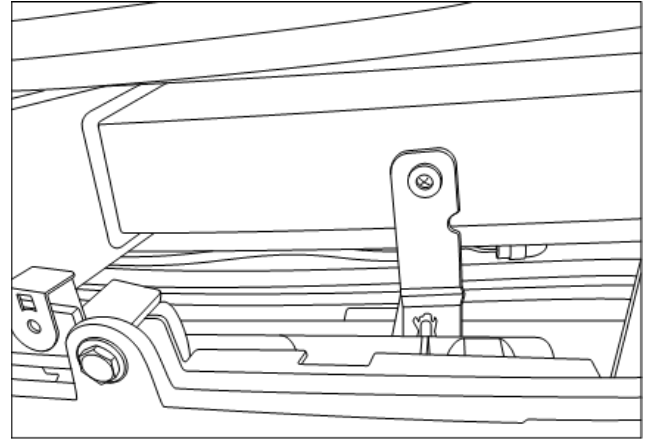

27. On underside protector, find the centre, mark off and cut out 90mm x 90mm as depicted.

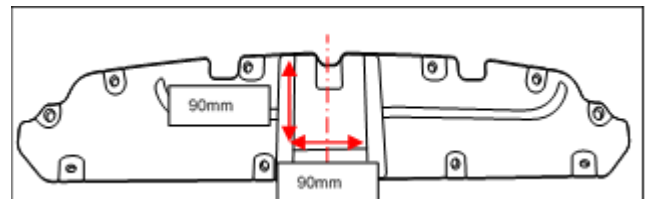

28. On the underside protector, at an appropriate position (LH side of the previous cut out), mark out and drill 2x \varnothing 5mm holes 69mm apart for the plug bracket.

Cut out a feedthrough slot for the wiring harness.

Fit the plug bracket to the underside protector.

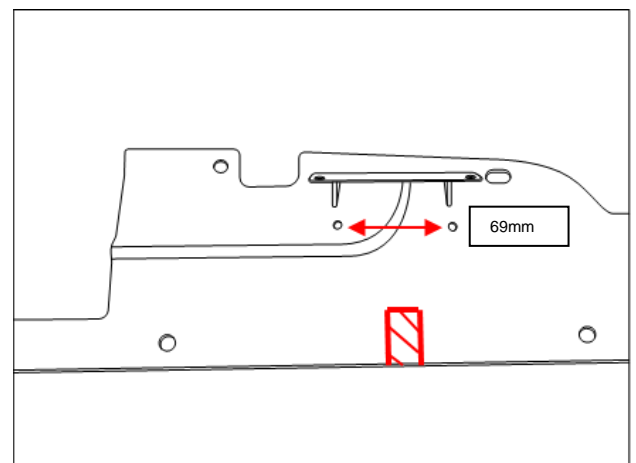



TOWBAR INSTALLATION INSTRUCTIONS

PART NUMBER 03286RW

BMW X3 G01 & X4 G02 CL4

29. Refit all removed components to the vehicle following steps 1 to 15 in reverse.

Use the supplied plastic rivets to attach the wheel arch trim removed in step 14.

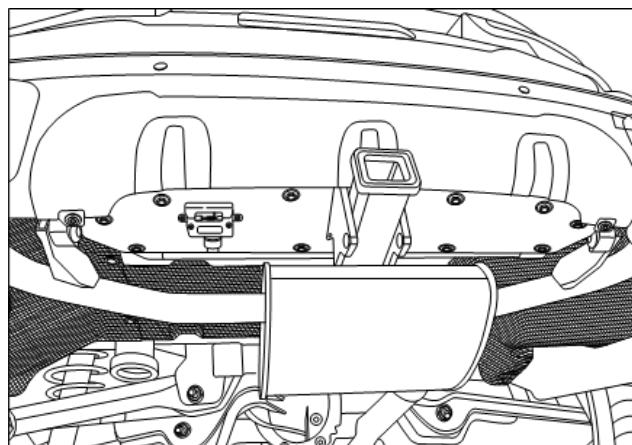



TOWBAR INSTALLATION INSTRUCTIONS

PART NUMBER 03286RW

BMW X3 G01 & X4 G02 CL4

IMPORTANT

Due to possible vehicle variations, always confirm any noted vehicle colour wires with a multi-meter to ensure the correct function is identified before soldering or scotch locking. For vehicle wires denoted with two colours (example; RED/GREEN) the first colour will always be the main wire colour while the second colour is the thinner trace colour on the wire.

30. Open the tailgate remove the RHS & LHS access panels

Fold the rear seats.
Remove the boot floor by removing the 2x Torx bolts.

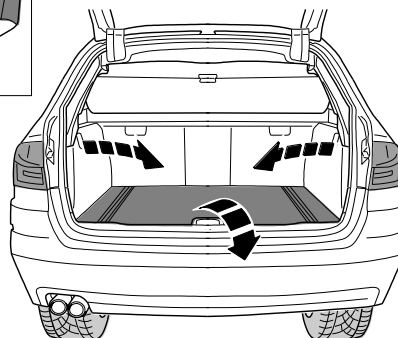
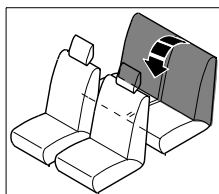

31. Remove the 2x screws that secure the side panel and move the panel to the side.

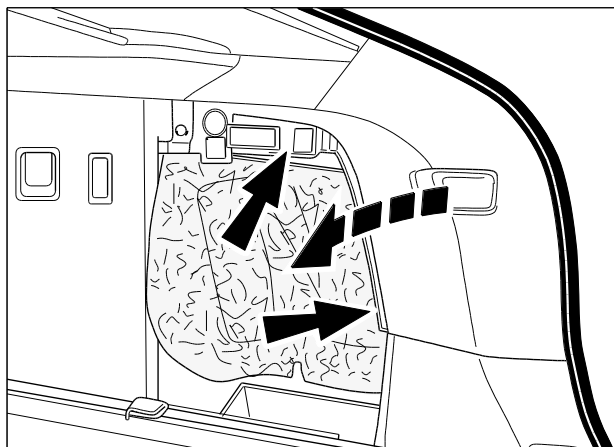

32. Remove the 2x scrivenets that hold the sill trim in place and remove the trim.

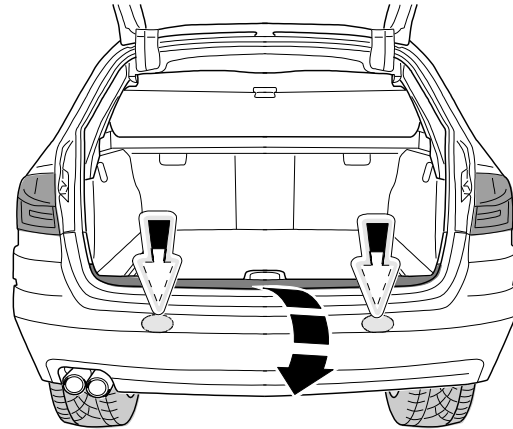

33. Remove the 3x Torx screws that secure the cargo track and remove.

Release the 3 scrivenets that secure the storage tub and remove.

Remove the side plastic bracket that will enable the cloth trim to be peeled back and give better access to vehicle wiring harness.

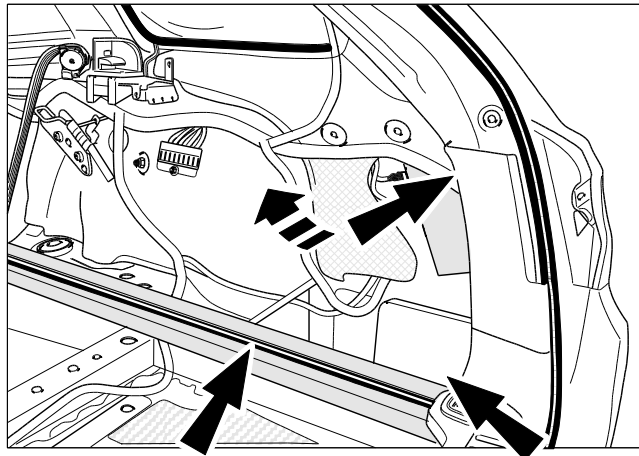

34. Remove the 3x Torx screws that secure the cargo track and remove.

Release the 3 scrivenets that secure the storage tub and remove.

Remove the side plastic bracket that will enable the cloth trim to be peeled back and give better access to vehicle wiring harness.

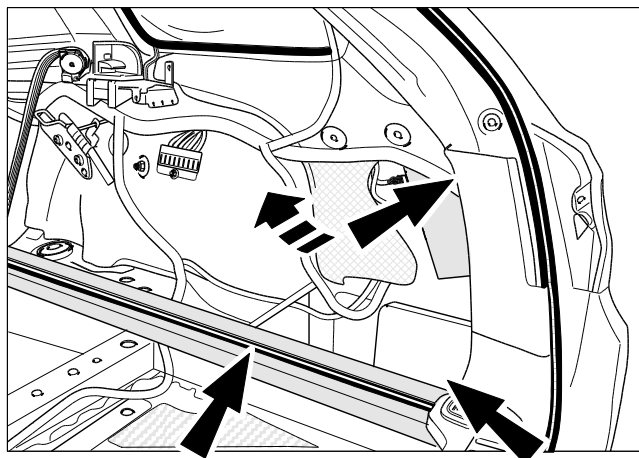

35. Locate the blanking grommet on the RHS and remove.

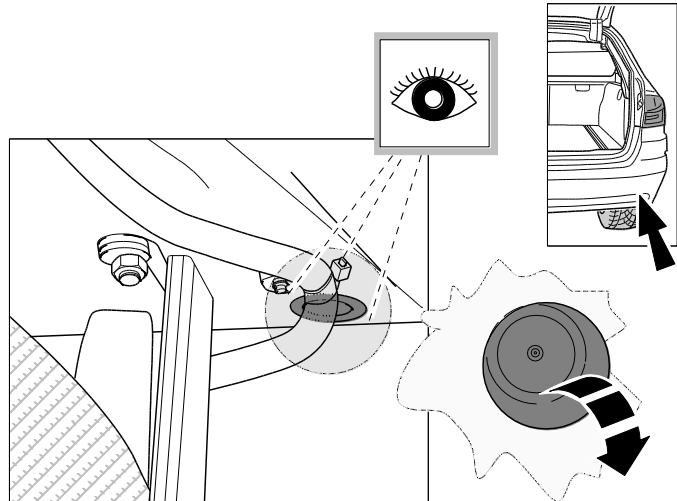

36. Drill it out to $\varnothing 30\text{mm}$ feed the tail harness (1800) blue connector through the blanking grommet, replace the blanking grommet back in the vehicle

Slide the tail grommet to desired location ensure the grommet is seated properly.

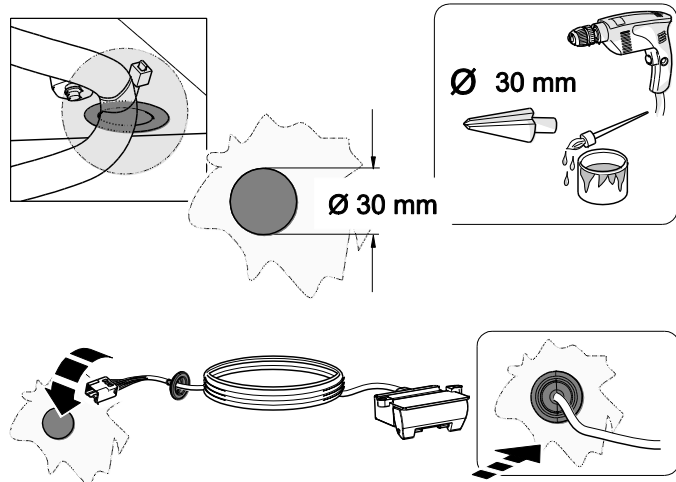

37. Run the tail 1800 where the socket will be mounted and slide the grommet to desired location and secure with a cable.

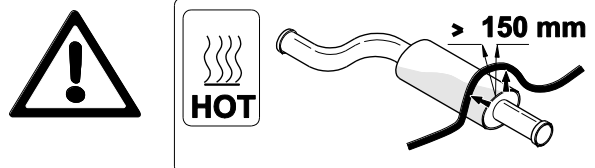
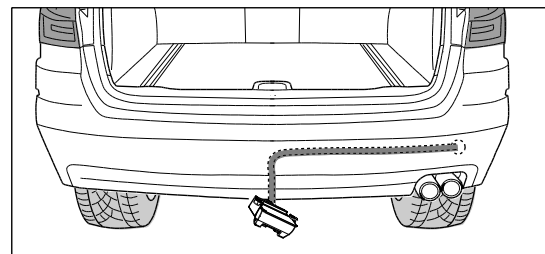



TOWBAR INSTALLATION INSTRUCTIONS

PART NUMBER 03286RW
BMW X3 G01 & X4 G02 CL4

38. Locate the 8-way tail harness connector and connect it to the 8-way female connector on the trailer patch.

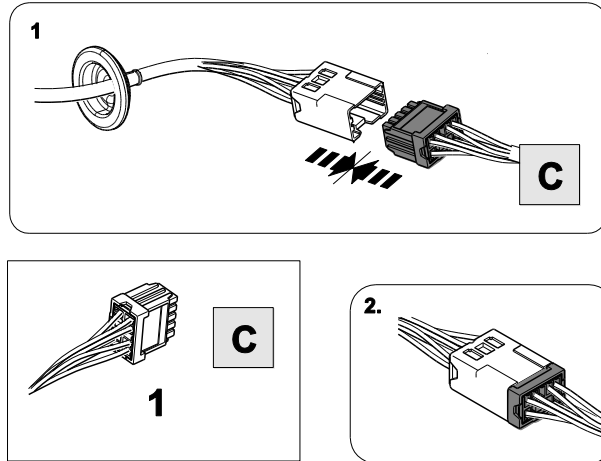

39. Locate and disconnect the white CAN connector position 1 and remove the shell.

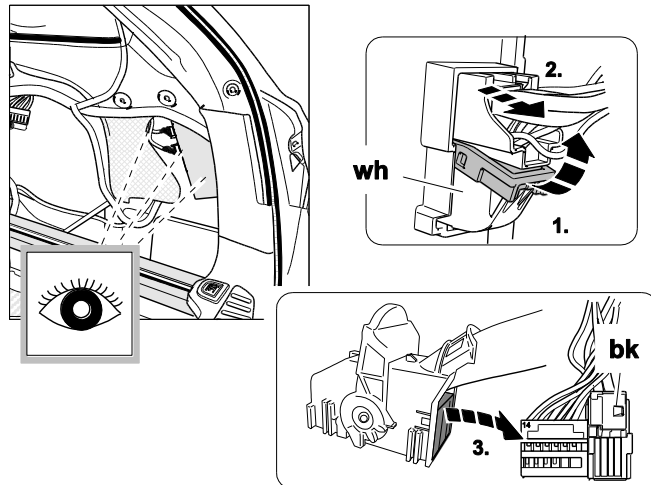

40. Unhouse using the following arrangement:

Pin 13 ye/rd (Yellow/Red)

Pin 14 ye/bn (Yellow/Brown)

41. Use enclosed the 3-way female connector and insert the previously removed wires into the following arrangement:

Yellow/Brown = Pin 1

Yellow/Red = Pin 3

42. Close the locking tab.

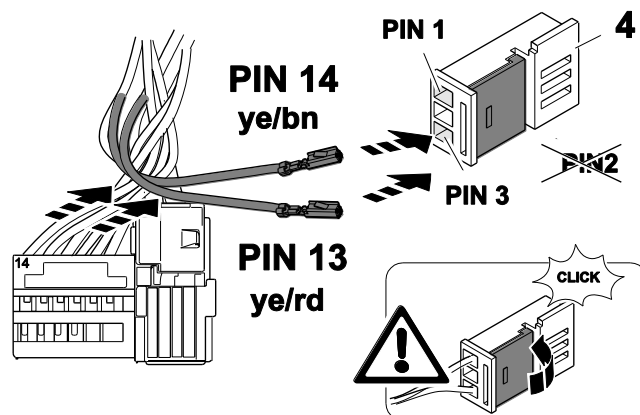



TOWBAR INSTALLATION INSTRUCTIONS

PART NUMBER 03286RW
BMW X3 G01 & X4 G02 CL4

43. Locate the CAN wires on the harness and insert the wires into the vehicle connector in the following arrangement:

Pin 13 Yellow/Red

Pin 14 Yellow

44. Connect the 3-way female connector with the counterpart.

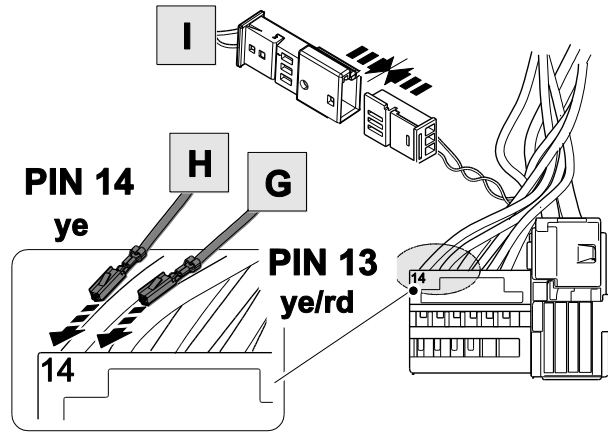

45. Assemble white CAN connector and reconnect in position 1.

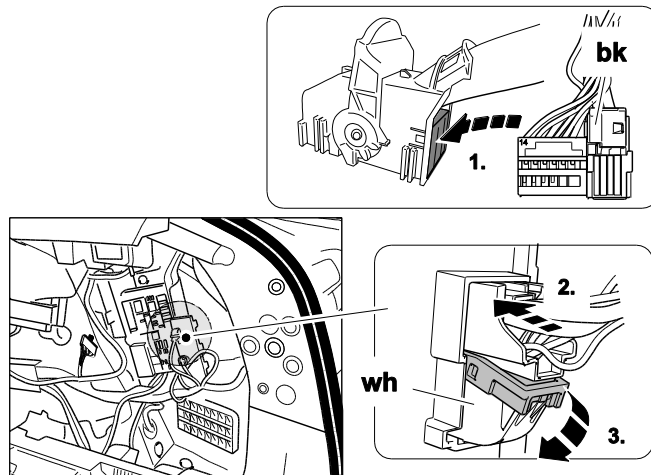

46. Locate the taillight harness and connect the following wire using a wiretap.

Harness bk-bu (Black/Blue) = bu-bn (Blue/Brown) R.IND Pin 1

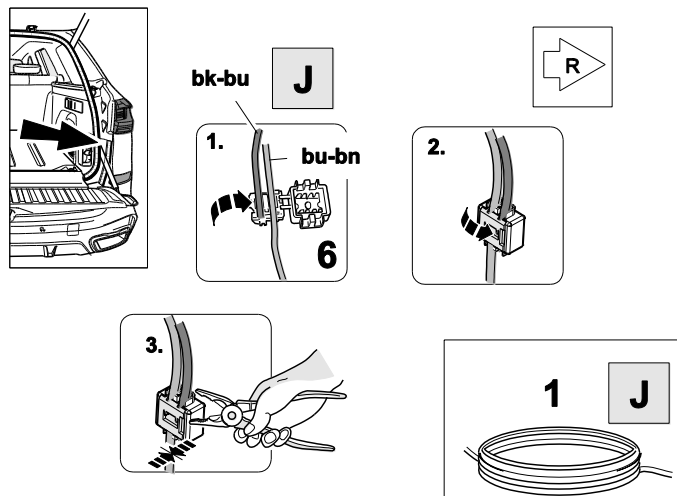



TOWBAR INSTALLATION INSTRUCTIONS

PART NUMBER 03286RW

BMW X3 G01 & X4 G02 CL4

47. >> G01

Locate the third brake light wire and connect the following wire using a wiretap.

Harness bk-ye (Black/Yellow) = gn-gy (Green/Gray) Third brake light

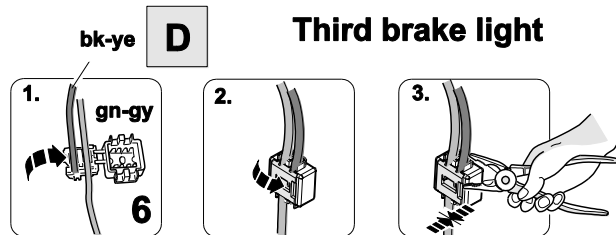
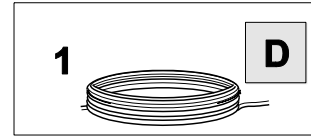
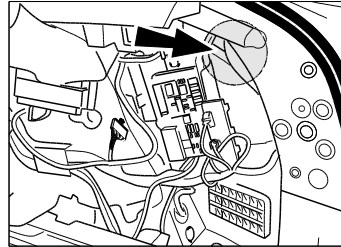

48. >> G02

Locate the third brake light wire and connect the following wire using a wiretap.

Harness bk-ye (Black/Yellow) = gn-gy (Green/Gray) Third brake light

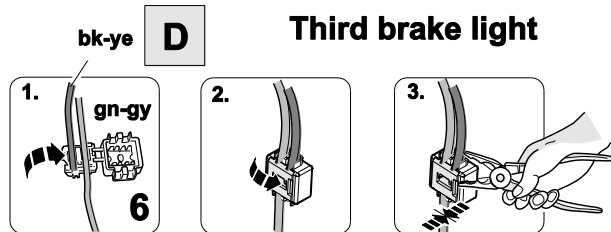
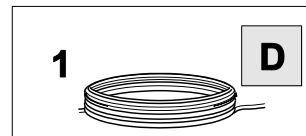
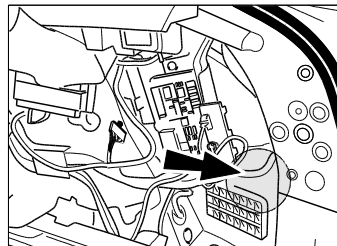

49. Connect Harness Ground ring terminals White & White/Brown to the factory Ground location.

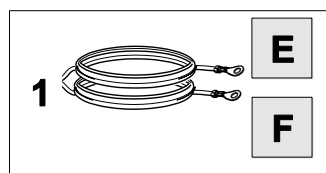

Ground!

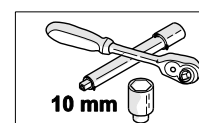
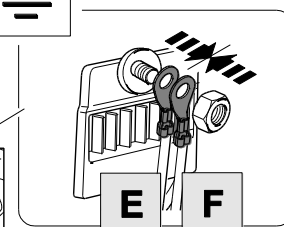
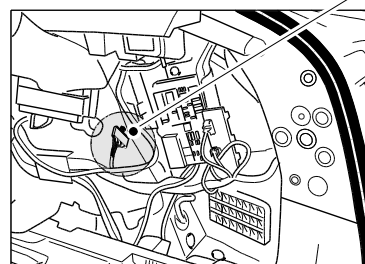



TOWBAR INSTALLATION INSTRUCTIONS

PART NUMBER 03286RW

BMW X3 G01 & X4 G02 CL4

50. Connect the trailer ECU. Peel the adhesive backing tape from the module, slide into the ECU Slot and press the module against this surface.

Apply pressure for 60 seconds to ensure good adhesion.

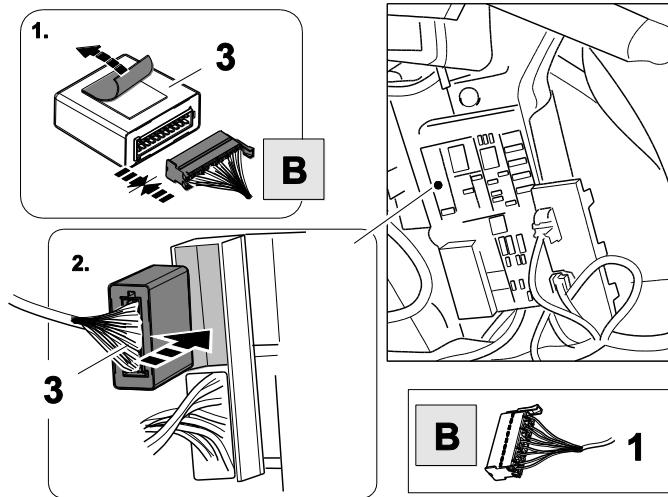

51. Route the power harness towards and insert into the fuse connector.

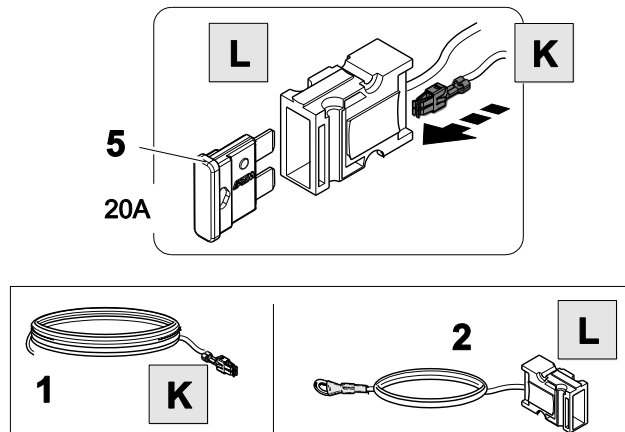

52. Secure the ring terminal to the positive terminal.

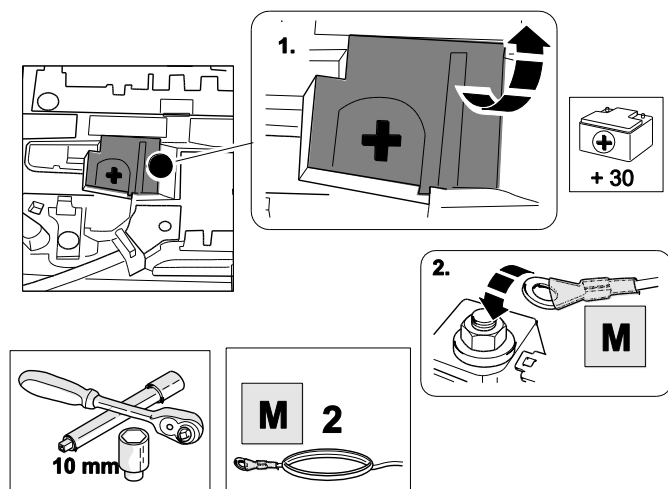



TOWBAR INSTALLATION INSTRUCTIONS

PART NUMBER 03286RW
BMW X3 G01 & X4 G02 CL4

53. Reconnect the battery.

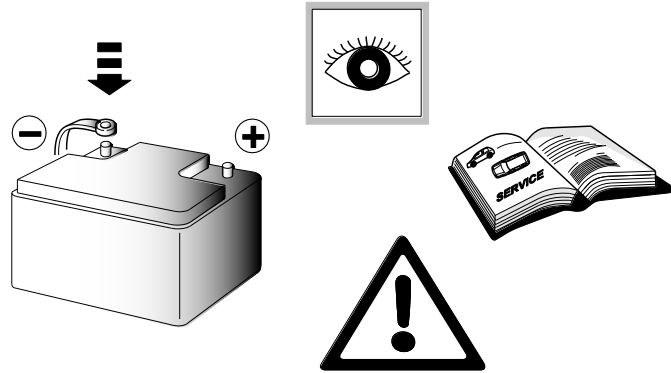

54. Check all light functions.

Before testing the lights with a tester or trailer connected, the trailer module must be activated by putting your foot on the brake.

This allows the module to detect if a trailer is connected. Once a trailer is disconnected, another press on the brake will enable the module to detect no trailer is connected.

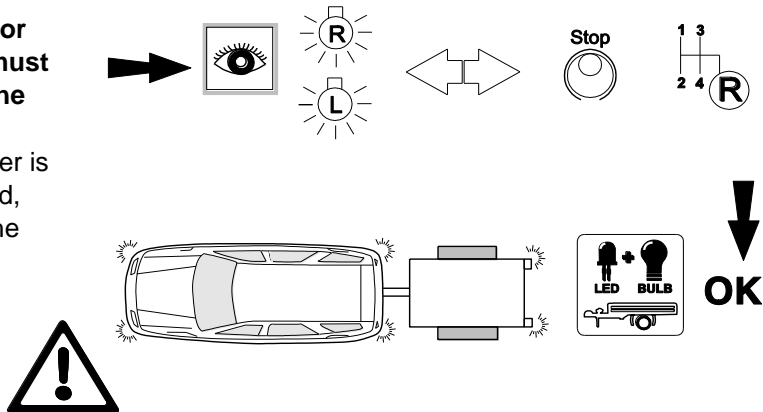

55. A trailer bulb out condition is indicated with an increased indicator frequency as well as a display on the dash.

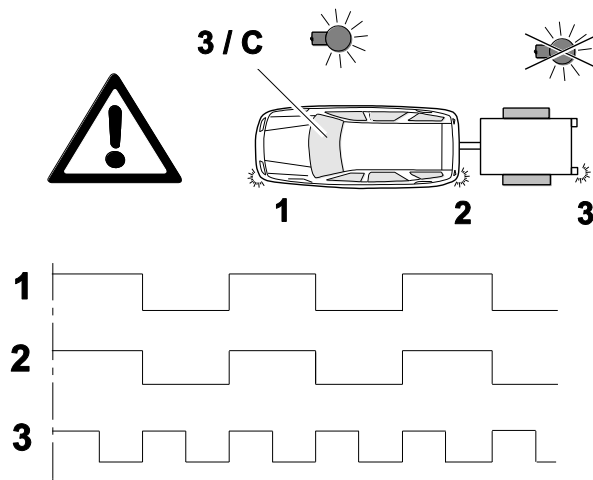



TOWBAR INSTALLATION INSTRUCTIONS

PART NUMBER 03286RW

BMW X3 G01 & X4 G02 CL4

56. Information service.

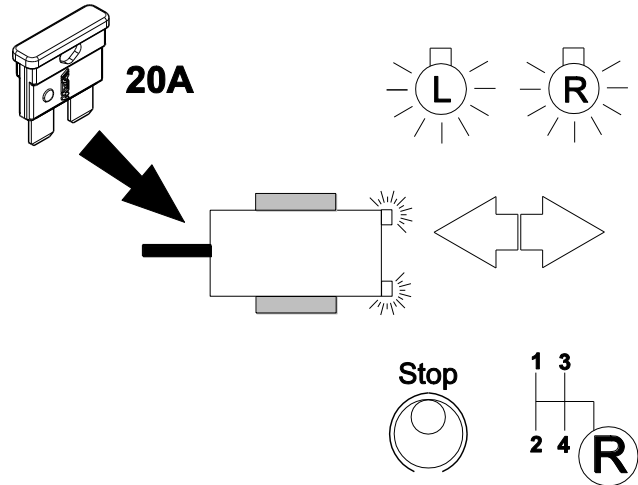

57. Reinstall all parts including the bumper mount the trailer socket.

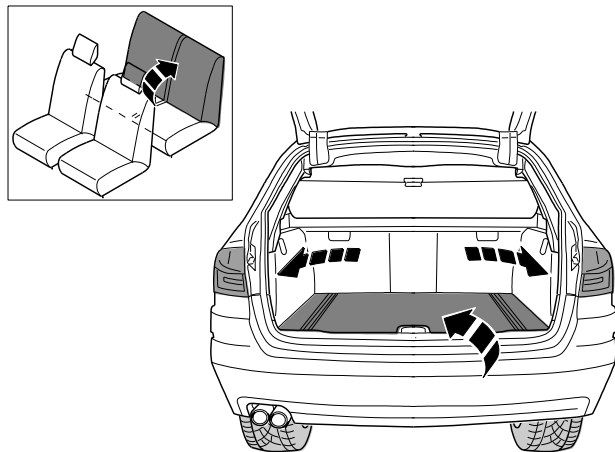

58. Information to enclosed Label Diagnostics CAN-Module.

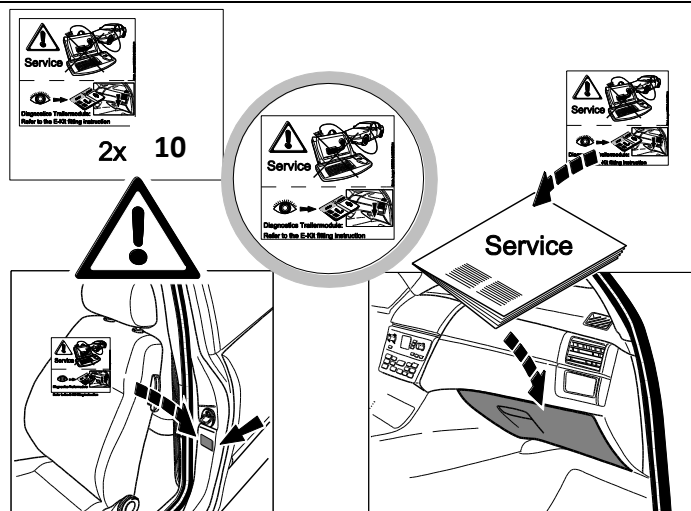

Operation support

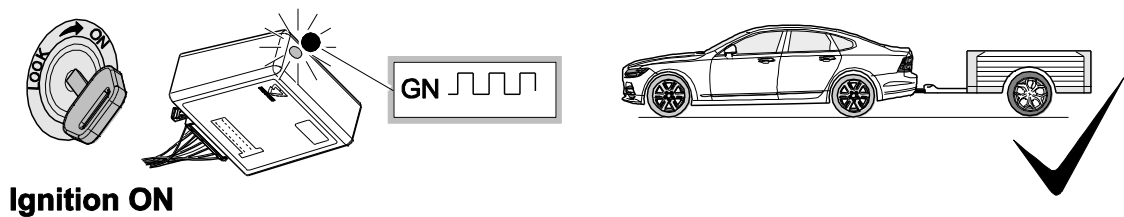
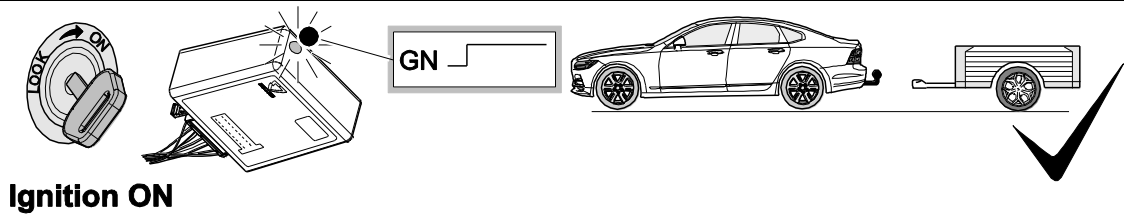
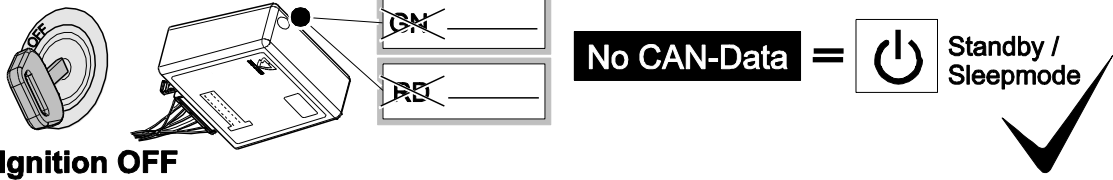

Failure support

Check CAN-Data Wire

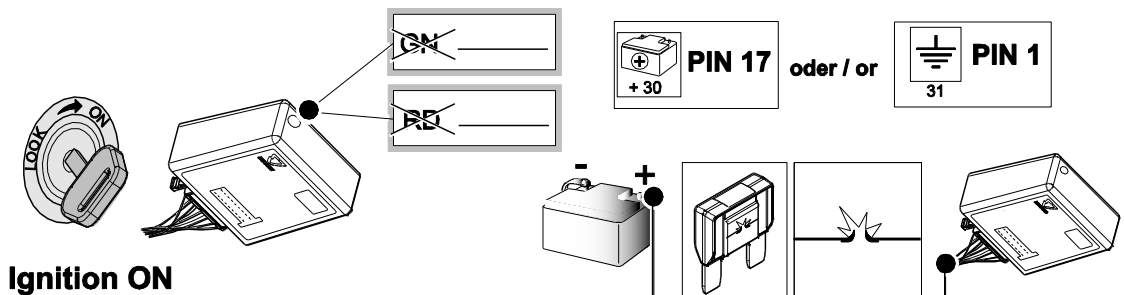
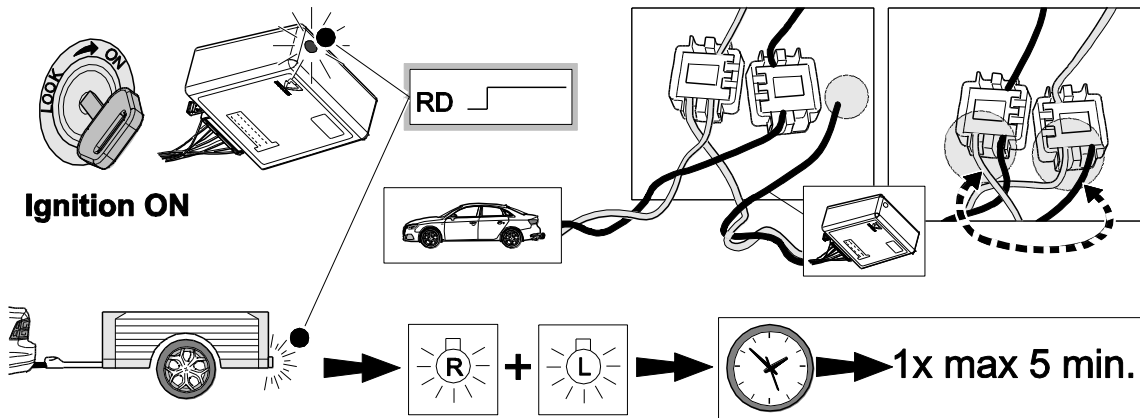



CUSTOMER INFORMATION

PLACE THESE INSTRUCTIONS IN THE VEHICLE'S GLOVEBOX AFTER INSTALLATION

**THANK YOU FOR PURCHASING HAYMAN REESE.
WITH CORRECT MAINTENANCE AND CARE THIS PRODUCT WILL PROVIDE A
LIFETIME OF TROUBLE-FREE OPERATION.**

TOWBAR MAINTENANCE AND CARE:

1. Hayman Reese recommend that the towbar LUG or TBM (tow ball Mount) Pull Pin and R-clip are removed and stored when not in use. Removal of LUG or TBM (tow ball mount) is advisable when not in use to assist with any of the following.
 - Ensure rear number plate is not obscured.
 - Allow maximum available departure angle and prevent any potential interference.
 - Prevent possible interference with vehicles reverse sensors or camera detecting a tow ball mount as an obstruction during reversing.
 - Removes towball mount as an obstruction for when moving around the rear of the vehicle.
2. Hayman Reese recommends routine inspection of your towbar to ensure trouble free towing.
 - Bolt security and tension should be regularly inspected and checked for correct tension. Replace any worn or defective parts with suitable grade & class fasteners. Inspection should be requested to coincide with vehicle major services.
3. It is the owner's responsibility to ensure towing and down ball weight capacities of the towing vehicle are not exceeded.
 - Towing and down ball weights allowable may differ according to model variations. Please refer to owner's manual or vehicle dealer to confirm exact rating for your vehicle model variant.
 - It is not uncommon for the vehicle tow rating to differ from the towbar rating. When this occurs, the lesser rating must be adhered to.
 - For vehicles fitted with enhanced vehicle functions that may be altered/changed when towing i.e Trailer sway mitigation, blind spot detection, adaptive cruise control etc. Please consult owner's manual to understand changes enabled when towing and after towing.



WARRANTY INFORMATION:

Hayman Reese Towbars are covered by a Lifetime Warranty.

Our goods come with guarantees that cannot be excluded under the Australian Consumer Law. You are entitled to a replacement or refund for a major failure and for compensation for any other reasonably foreseeable loss or damage. You are also entitled to have the goods repaired or replaced if the goods fail to be of acceptable quality and the failure does not amount to a major failure.

For further details please visit www.haymanreese.com.au/warranty or contact customer service on 1800 812 017 or info@haymanreese.com.au.



CUSTOMER INFORMATION

PLACE THESE INSTRUCTIONS IN THE VEHICLE'S GLOVEBOX AFTER INSTALLATION

HAYMAN REESE SMART PIN

Your Hayman Reese towbar is equipped with Smart Pin technology to help reduce towbar tongue rattle in most driving conditions. Please ensure below instructions are understood and routine maintenance is carried out to ensure best towing experience.

i Regularly inspect for wear and check the tightness of the Smart Pin Nut. Follow instructions below to re-tighten the nut as necessary when movement and noise in the tow ball mount is noted.

- Before towing, ensure R-Clip is properly installed and Smart pin nut is installed and tensioned. Replacement parts are available from your Hayman Reese Distributor.

TOWBALL MOUNT REMOVAL/INSTALLATION

STEP 1

Insert Trailer Ball Mount (TBM) (a) into towbar hitchbox (b), aligning hole in TBM shank (c) with hole in hitchbox (d) (Fig. 1)

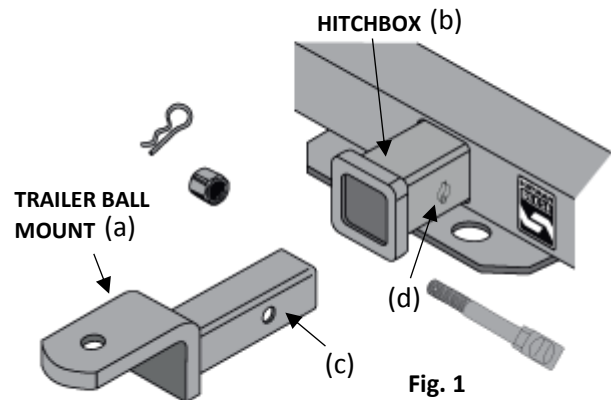

STEP 2

Insert Smart Pin (e) through hole in hitchbox and hole in TBM shank (g); ensure the locators are inserted into the notches in the hitchbox (Fig. 2)

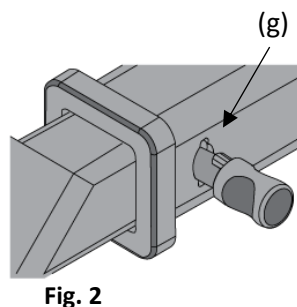

STEP 3

Screw Smart Pin Nut (f) onto Smart Pin (g); tighten Smart Pin Nut until finger tight, ensuring TBM is restrained from up and down movement.

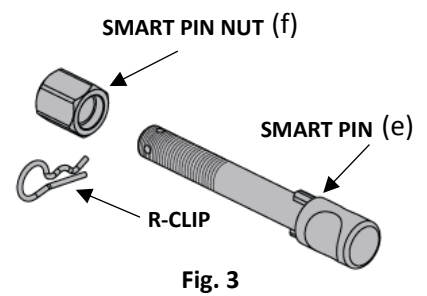

STEP 4

Tighten Smart Pin Nut by turning nut a further 1/8th of a turn in the clockwise direction using a 24mm spanner (Fig. 4).

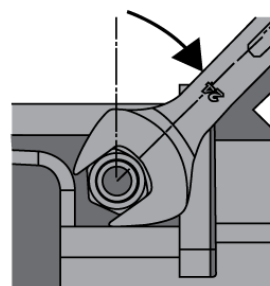

STEP 5

Install Smart Pin R-Clip through the hole that provides best clearance or easiest access. (Fig. 5)

