



# TOWBAR INSTALLATION INSTRUCTIONS

PART NUMBER 03402RW

HAVAL H6 B01 CL4



## PRODUCT DETAILS:

Part Number:	03402RW	Maximum Towing Braked:	2000	kg
ECU Number:	04826	Maximum Towing Unbraked:	750	kg
Tail Harness Length Required:	1800 mm	Maximum Static Ball Load:	200	kg
TBM/Lug Part Number:	21325			
Wiring Part Number:	102695-WL			

## FITTING DETAILS:

Towbar Installation Time:	120 Mins.	Hayman Reese SmartCODE Solution Required:	NO
Wiring Installation Time:	60 Mins.	RPA Disable/Other:	YES
Total Installation Time:	180 Mins.	Note:	
Bumper Cut Required:	Yes	<ul style="list-style-type: none"><li>04937 for RPA Disable</li></ul>	



# TOWBAR INSTALLATION INSTRUCTIONS

PART NUMBER 03402RW

HAVAL H6 B01 CL4

**ENSURE THAT INSTRUCTIONS ARE UNDERSTOOD PRIOR TO FITMENT.**

## **i** BEFORE YOU START:

Hayman Reese recommends that instructions are read completely prior to fitment. Check all hardware items have been included refer to assembly diagram. Please ensure this towbar is only fitted to vehicle models as per Hayman Reese application guide ([www.haymanreese.com.au](http://www.haymanreese.com.au)).

### **Bumper Cuts**



Vehicle and bumper variations can and do occur during vehicle manufacture after initial towbar design. Fitment of towbar to vehicle and accuracy of bumper cut must be assessed prior to any bumper modifications made. Incorrect bumper cuts are not covered under Hayman Reese warranty.

**NOTE: Bumper cuts need to be approached with care, refer to notes below.**

- Bumper centreline – where the centreline of the bumper needs to be determined, the installer must assess centre point by measurement of bumper width or determining two symmetrical reference points to give centreline.
- Bumper edge – To assist with accurate bumper cut measurement, reference to the start of the bumper edge is now being commonly used.
  - Measure from bottom edge along bumper and around corner to the 70 mm point (Figure 1).
  - Do not measure from visible bumper front of corner, upwards (Figure 2).

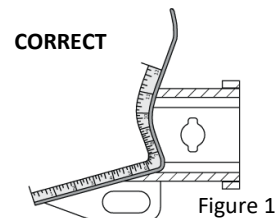

Figure 1

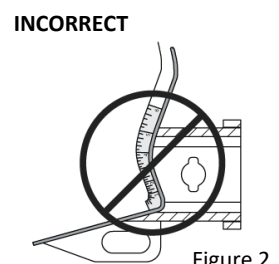

Figure 2

### **Drilling**

- For any required drilling during installation, ensure that the area is clear of fuel, electrical & other components that may be damaged.
- All holes drilled into the body panels shall have all burrs & swarf removed then coated with a suitable rust preventative paint.

### **Bolts/Fasteners**

- Ensure that all hardware is fastened to correct torque as specified in this fitting instruction.
- All fasteners supplied with this product are used to achieve a specified clamp loading. If replacement is required ensure that fasteners of the same grade and class are used.



**NOTE: Achieving correct torque is critical to proper installation and responsibility of the installer. Towbar failures attributed to tension issues from over tightening or under tightening are not covered by Hayman Reese warranty.**

### **Product Labels**

- a. Towbar load rating sticker provided with this product shall be conspicuously located on inside rear end of the driver's door.
- b. Powertrain Control Module (PCM)/Body Control Module (BCM) upgrade warning label will be provided in towbar kit for vehicles as required. Affix warning label in door and owner's handbook.

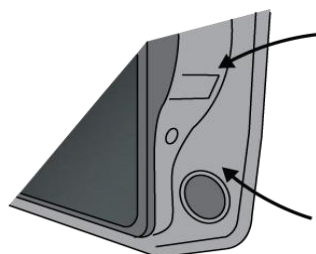

Place **Load Rating sticker** inside driver's door here

Place **Vehicle PCM/ BCM upgrade warning label** in door AND on front cover of owner's service handbook

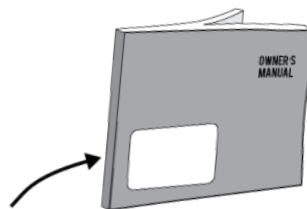

## **WARNING:**

**Do not, drill, cut, weld or otherwise modify the towbar.**

**FOR TOWING PURPOSES ONLY - This towbar is designed and tested by Hayman Reese to adhere to ADR 62/02 which provides only for the expected load demands of towing.**



# TOWBAR INSTALLATION INSTRUCTIONS

PART NUMBER 03402RW

HAVAL H6 B01 CL4

## **i** TOWBAR ASSEMBLY DIAGRAM

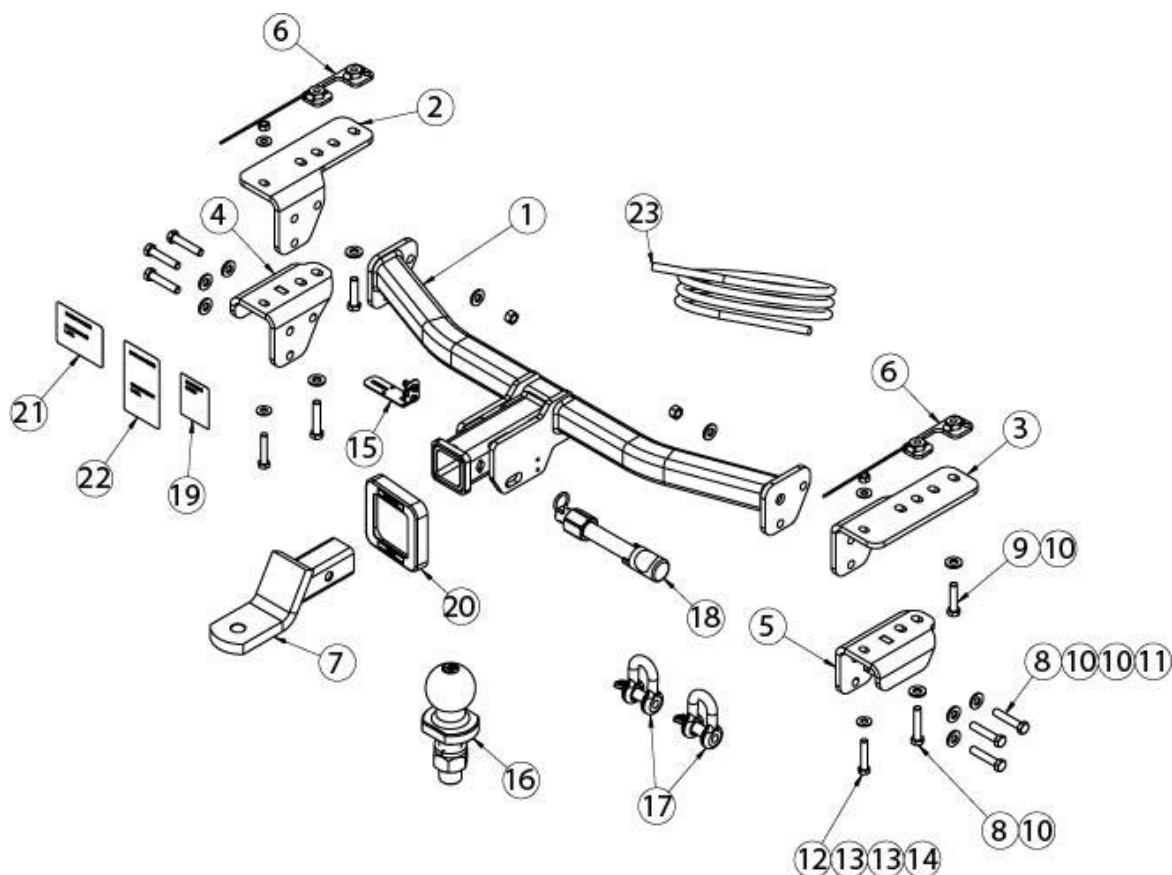

ITEM	DESCRIPTION	QTY
1	HAVAL H6 MY21 AM TOWBAR	1
2	SIDE ARM SUPPORT LH	1
3	SIDE ARM SUPPORT RH	1
4	SIDE ARM SUPPORT ASSY LH	1
5	SIDE ARM SUPPORT ASSY RH	1
6	M12 COARSE PITCH WELD NUT ASSY	2
7	TRAILER BALL MOUNT	1
8	BOLT HEX HD M12x60x1.75P	8
9	BOLT HEX HD M12x50x1.75P	2
10	WASHER PLAIN 1/2"	14
11	NUT HEX HD M12x1.75P	4
12	BOLT HEX M10xx55x1.5P	2

ITEM	DESCRIPTION	QTY
13	WASHER PLAIN M10x23x2	4
14	NUT HEX HD M10x1.5P	2
15	UNIVERSAL PLUG BRACKET KIT	1
16	TOWBALL 50mm	1
17	"D" SHACKLE 10mm	2
18	SMART PIN GOLD	1
19	HAYMAN REESE LOGO STICKER	1
20	HITCH BOX COLLAR COVER	1
21	COMPLIANCE LABEL	1
22	LOAD RATING LABEL	1
23	WIRING LOOM	1

1. Release the rear lift gate to expose the boot cabin.

Remove the 2 x Tail light fastener covers.

Remove the 2x Screws from taillight and 2 x  
Screws from the bumper.

Repeat for the other side

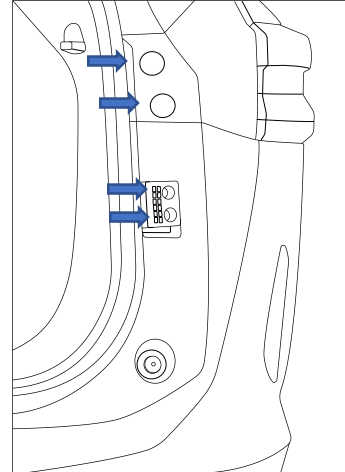

2. Pull the taillight rear ward and disconnect wiring.

Repeat for the other side

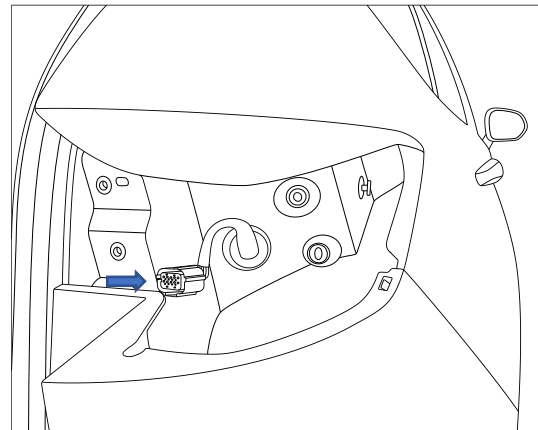

3. Remove 1x Torx screw securing bumper to vehicle.

Repeat for the other side

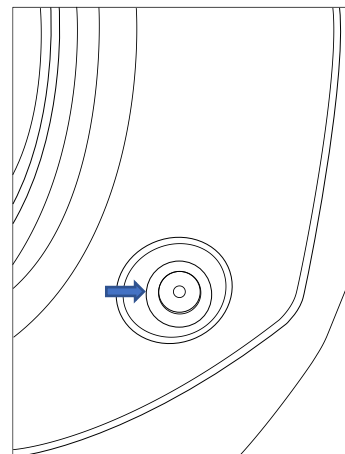



# TOWBAR INSTALLATION INSTRUCTIONS

PART NUMBER 03402RW

HAVAL H6 B01 CL4

- 
4. Remove 3x screws connecting wheel arch liner to the rear bumper.

Repeat for other side.

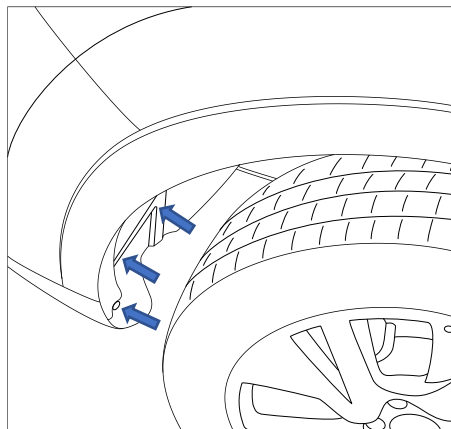

- 
5. Unclip Peel back the side guard mouldings to expose and remove the 1 x Screw.

Repeat for other side

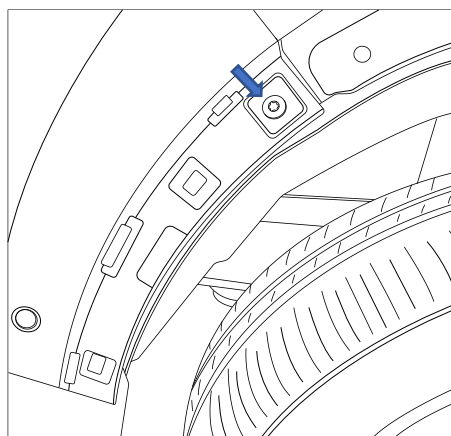

- 
6. Remove 4x screws connecting the underside of the rear bumper.

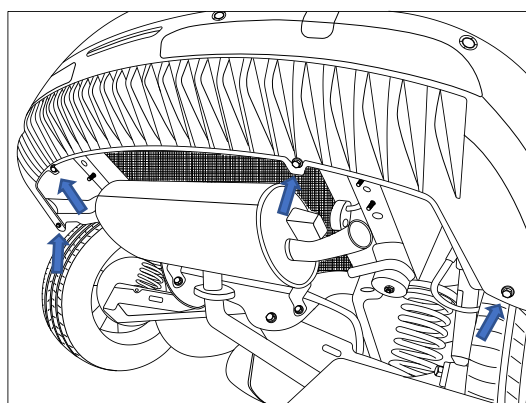



# TOWBAR INSTALLATION INSTRUCTIONS

PART NUMBER 03402RW

HAVAL H6 B01 CL4

- 
7. Unclip the rear bumper.

Repeat for the other side

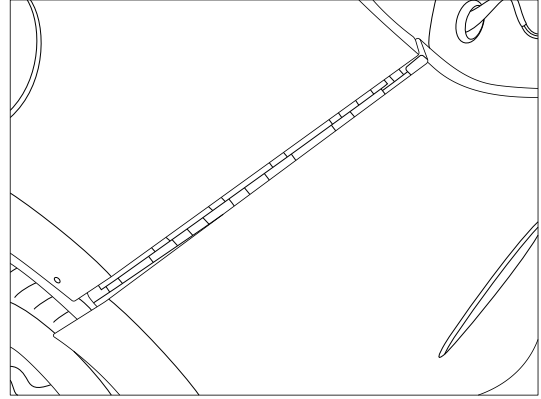

- 
8. Carefully Remove rear bumper and disconnect wiring loom from LHS of vehicle.

Store safely to avoid damage.

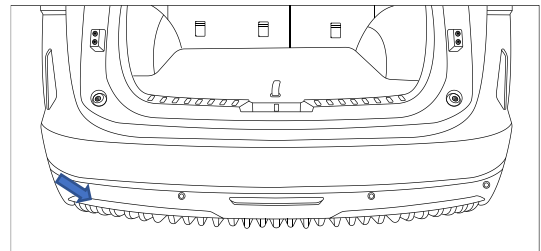

- 
9. Detach the wiring loom from the impact beam and remove the impact beam by removing the 8 x M10 HEX NUTS.

Retain Impact Beam and nuts.

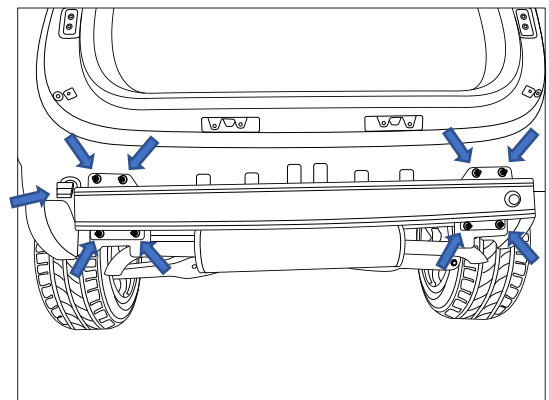



# TOWBAR INSTALLATION INSTRUCTIONS

PART NUMBER 03402RW

HAVAL H6 B01 CL4

10. Drill out hole location (2) to 13mm on both sides.  
Use 10mm chassis hole as guide.

Loosely attach the Side Arms by inserting the Weld nut assembly into the chassis rail and fastening the Side Arm support & Side Arm Support Assembly Brackets using 1 x M12-1.75x50 BOLT (1), 1x M12-1.75P BOLT (2) and 2 x M12 WASHER, 1 x M10 x 1.5x55 BOLT (3), M10 Washer and 1 x M10-1.5 Hex Nut as shown.

Repeat for other side

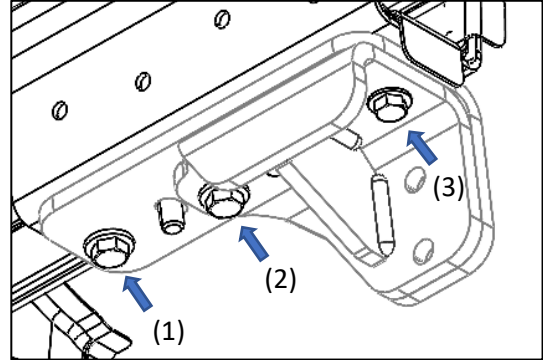

11. Loosely place the Towbar Welded Assembly between the side arms using 3x M12-1.75x60 BOLTS & 4 M12 3x WASHERS, & 2 x M12-1.75 NUTS.

Repeat for other side.

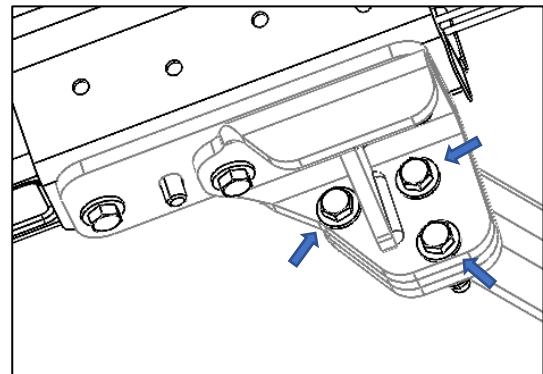

12. With the towbar now fitted Torque all Fasteners on both sides as follows:

**M12 BOLTS = 77Nm**

**M10 BOLTS = 44Nm**

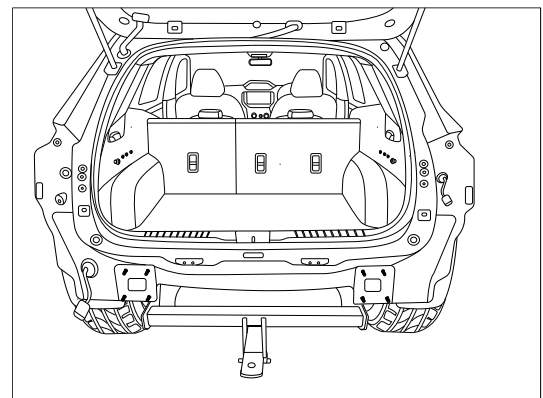



# TOWBAR INSTALLATION INSTRUCTIONS

PART NUMBER 03402RW

HAVAL H6 B01 CL4

13. Fit the plug bracket to the dropper and secure with 2x M4 screws, 4x washers and 2x nuts.

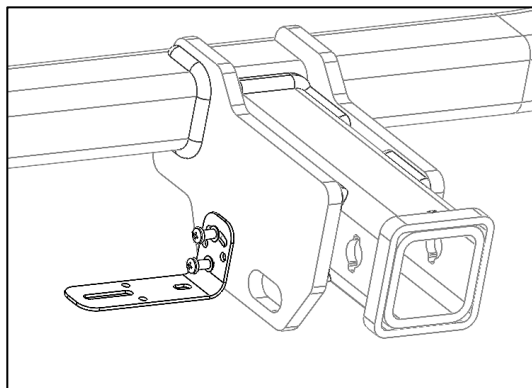

14. Using masking tape, mark and cut out an area as shown to clear the hitch box. Cut out is on bumper centre line.

Remove all swarf and rough edges.

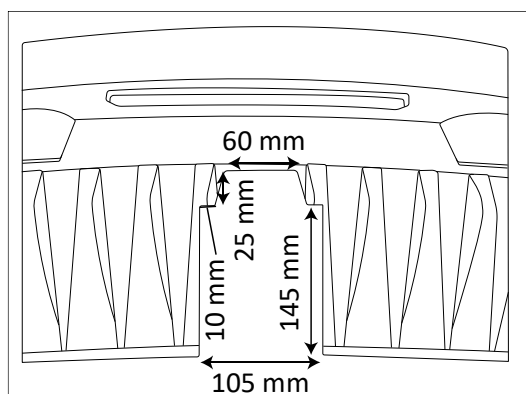

15. Re-fit all removed parts and secure all fasteners, ensuring there are no squeaks or rattles.

Following steps 1-9, in reverse





# TOWBAR INSTALLATION INSTRUCTIONS

PART NUMBER 03402RW

HAVAL H6 B01 CL4

## IMPORTANT

Due to possible vehicle variations, always confirm any noted vehicle colour wires with a multi-meter to ensure the correct function is identified before soldering or scotch locking. For vehicle wires denoted with two colours (example; RED/GREEN) the first colour will always be the main wire colour while the second colour is the thinner trace colour on the wire.

16. In the Engine Bay, disconnect the vehicle battery negative terminal (1).

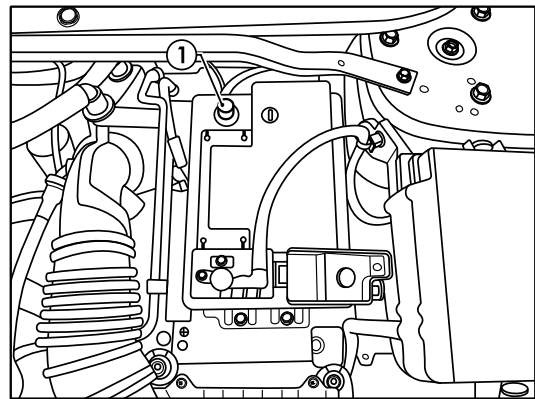

17. At the rear of the vehicle, remove the two caps (1) and bolts (2) securing the Tail Lamps.
18. Dislodge the tail lamps and disconnect the connectors before removing both Tail Lamp Assemblies.
19. Remove Rear Scruff plate (3) by unclipping the two push clips.

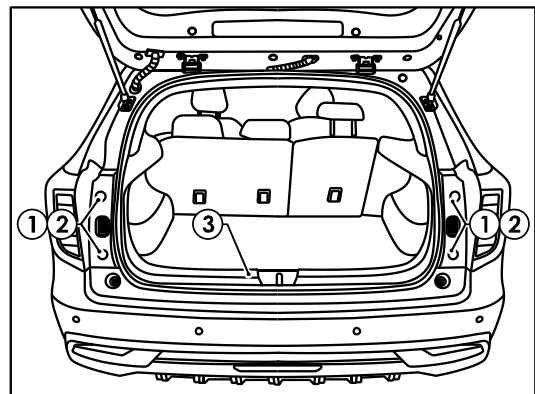

20. Fold down rear passenger seats.
21. Remove Luggage Compartment Floor exposing the vehicle spare tyre.
22. Remove polystyrene insert, wingnut, plate to remove the spare Tyre.
23. Remove the plastic nuts to remove the polystyrene insert and tools.

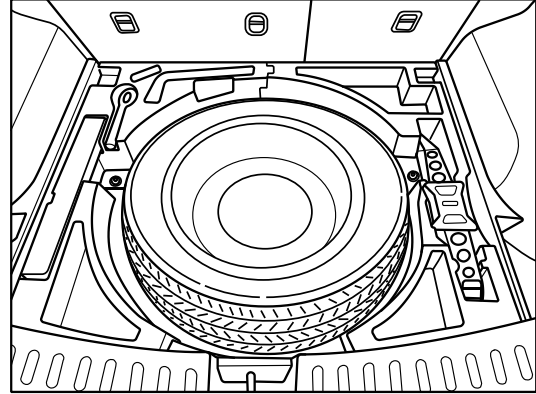

24. Remove screws and bolts holding both the RHS & LHS Rear Interior Trim (1).
25. Dislodge both the RHS & LHS Rear Interior Trim (1) towards the centre of the vehicle.

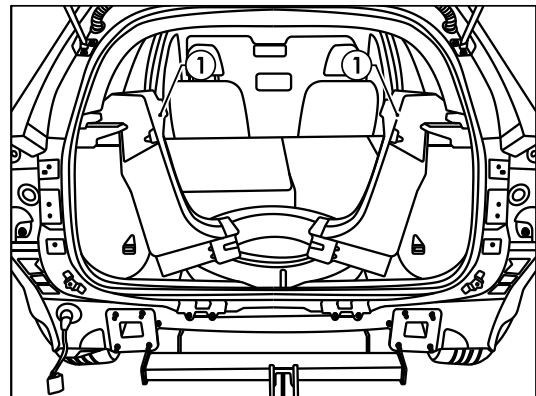

26. For Haval H6, house the 4 terminals (1) into the LHS Male/Female Tail Light Connector (2) on the harness according to the table and images below.

Cavity Number	Function	Trailer Patch
1	Pass Thru	Grey
2	Tail	Brown/Black
3	Stop	Red/Black
4	LHS Indicator	Yellow/Black
5	-	Grey

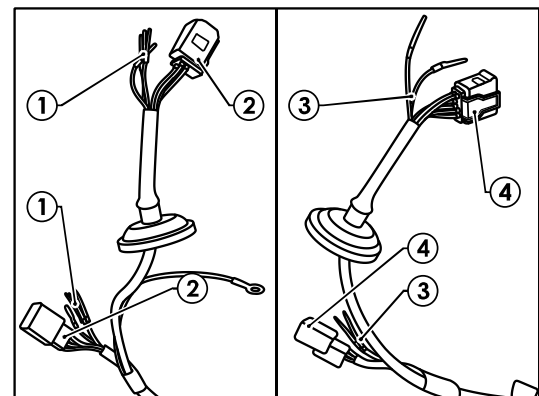



# TOWBAR INSTALLATION INSTRUCTIONS

PART NUMBER **03402RW**  
**HAVAL H6 B01 CL4**

27. For Haval H6, house the 2 terminals **(3)** into the RHS tail light connector **(4)** on the harness according to the table below.

Cavity Number	Function	Trailer Patch
1	-	Grey
2	-	Grey
3	Pass Thru	Grey
4	RHS Indicator	Green/Black
5	-	Grey

28.

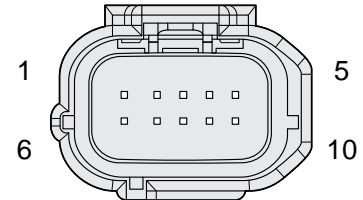

FRONT VIEW

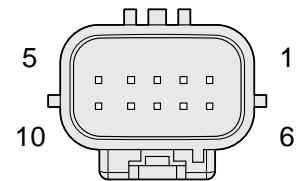

FRONT VIEW

28. Push the Vehicle LHS tail lamp grommet **(1)** and connector inside the vehicle and connect the vehicle LH tail lamp connector to the mating Trailer Harness connector.
29. Pull the Trailer Wiring Harness LHS tail lamp connector back thru the hole and secure the grommet.
30. Route the Trailer Wiring Harness across to the RHS Tail Lamp and repeat the above process, ensuring to tuck the harness as you go.

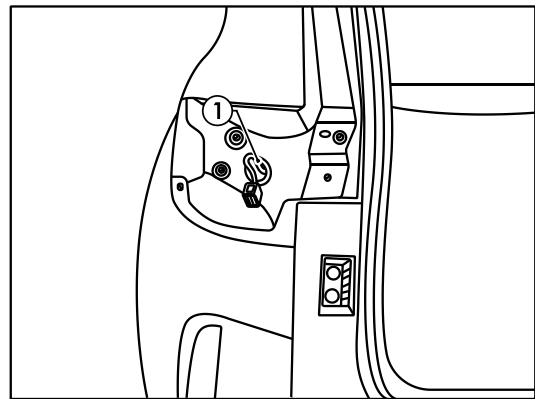

31. Behind the LHS rear panel, clean ECU mounting location **(1)** shown and base of ECU **(2)** using supplied cleaning pad.
32. Connect the Trailer Harness 12-way connector **(3)** to ECU **(2)** and mount in the location shown using the supplied Double Sided Tape **(4)**.
33. Secure Trailer Harness **(7)** to existing vehicle harness using supplied 200mm cable ties.

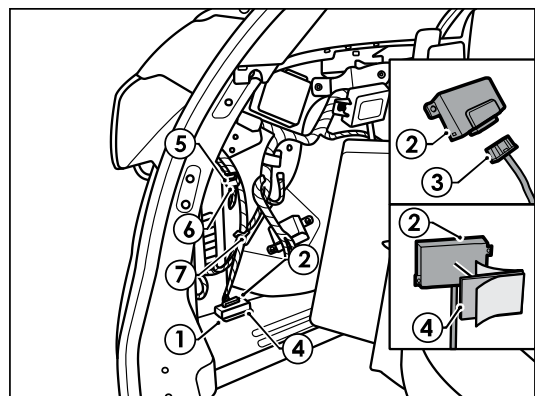

34. In the rear Cabin Area, connect the white M6 ground wire ring terminal to the vehicle earthing point **(1)** on the rear arch.

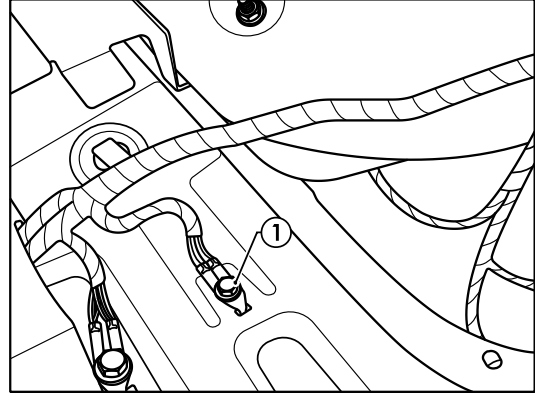

35. Route the orange power wire towards the vehicle interior Fuse box.  
36. Tuck the power wire under the trim as required.  
37. Remove Fuse box Cover to expose 6mm positive stud **(1)**. Connect the M6 positive ring terminal to the positive stud **(1)** on the fuse box.

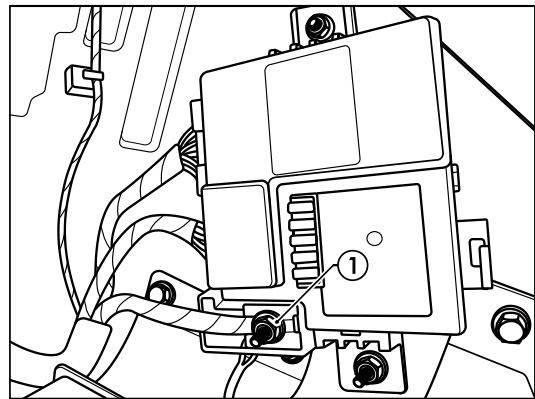

38. On the LHS of the vehicle remove the existing grommet **(1)** and drill out the hole to 30mm.

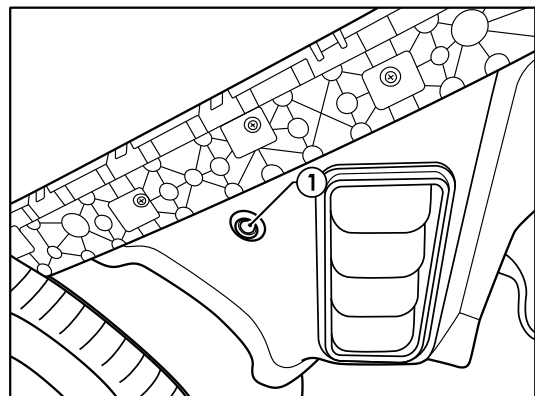



# TOWBAR INSTALLATION INSTRUCTIONS

PART NUMBER 03402RW

HAVAL H6 B01 CL4

39. With the rear bumper removed, secure tail harness to towbar.
40. Route tail harness up through chassis and previously drilled 30mm hole.
41. For RPA Disable route Grey and Grey/Black Wire back through grommet neck to outside of vehicle.
42. Seat grommet in 30mm hole and route to trailer harness blue connector on patch loom.

**Note: Keep harness routing clear of all sharp edges, moving parts and places of extreme heat.**

**Note: Ensure grommet is seated correctly and makes a good seal.**

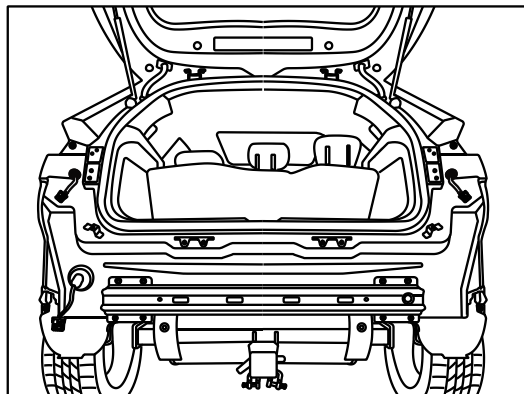

43. For RPA Disable locate the bumper connector on the LHS rear of the vehicle.

**Note: RPA Disable Grey & Grey/Black Wires may need to be extended.**

**For Haval H6 build date prior to 06/21**

44. Peel back the tube on Pin 13 Black/Yellow wire (2) on the 26 Way Connector and cut it 100mm back from the connector. Strip, crimp, and seal the tail harness (04937) GREY and GREY/BLACK wires to the vehicle Pin 5 Black/Yellow wire (2). (1 wire going to each side of the Black/Yellow wire).

**For Haval H6 build date after 07/21**

45. Peel back the tube on Pin 6 Red/Yellow wire (2) on the 26 Way Connector and cut it 100mm back from the connector. Strip, crimp, and seal the tail harness (04937) GREY and GREY/BLACK wires to the vehicle Pin 6 Red/Yellow wire (2). (1 wire going to each side of the Red/Yellow wire).

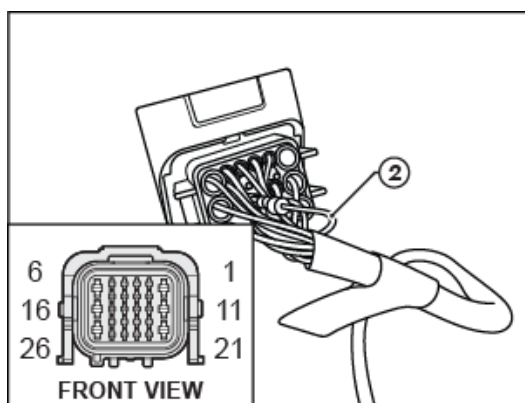

46. Connect the tail harness (tail length 1200mm) 8-way connector to the trailer patch mating 8-way connector.
47. Use silicone grease to seal the blue connectors.
48. Secure all harness using supplied cable ties.
49. Reconnect Negative Battery Terminal.
50. Re-fit all removed parts and secure all fasteners, ensuring there are no squeaks or rattles.
51. Test the trailer patch function using a light board or multi-meter.
52. Place the fitting instructions in the glove box after fitment.



# CUSTOMER INFORMATION

PLACE THESE INSTRUCTIONS IN THE  
VEHICLE'S GLOVEBOX AFTER INSTALLATION

**THANK YOU FOR PURCHASING HAYMAN REESE.  
WITH CORRECT MAINTENANCE AND CARE THIS PRODUCT WILL PROVIDE A  
LIFETIME OF TROUBLE-FREE OPERATION.**

## **i** TOWBAR MAINTENANCE AND CARE:

1. Hayman Reese recommend that the towbar LUG or TBM (tow ball Mount) Pull Pin and R-clip are removed and stored when not in use. Removal of LUG or TBM (tow ball mount) is advisable when not in use to assist with any of the following.
  - Ensure rear number plate is not obscured.
  - Allow maximum available departure angle and prevent any potential interference.
  - Prevent possible interference with vehicles reverse sensors or camera detecting a tow ball mount as an obstruction during reversing.
  - Removes towball mount as an obstruction for when moving around the rear of the vehicle.
2. Hayman Reese recommends routine inspection of your towbar to ensure trouble free towing.
  - Bolt security and tension should be regularly inspected and checked for correct tension. Replace any worn or defective parts with suitable grade & class fasteners. Inspection should be requested to coincide with vehicle major services.
3. It is the owner's responsibility to ensure towing and down ball weight capacities of the towing vehicle are not exceeded.
  - Towing and down ball weights allowable may differ according to model variations. Please refer to owner's manual or vehicle dealer to confirm exact rating for your vehicle model variant.
  - It is not uncommon for the vehicle tow rating to differ from the towbar rating. When this occurs, the lesser rating must be adhered to.
  - For vehicles fitted with enhanced vehicle functions that may be altered/changed when towing i.e Trailer sway mitigation, blind spot detection, adaptive cruise control etc. Please consult owner's manual to understand changes enabled when towing and after towing.

## **i** WARRANTY INFORMATION:

Hayman Reese Towbars are covered by a Lifetime Warranty.

Our goods come with guarantees that cannot be excluded under the Australian Consumer Law. You are entitled to a replacement or refund for a major failure and for compensation for any other reasonably foreseeable loss or damage. You are also entitled to have the goods repaired or replaced if the goods fail to be of acceptable quality and the failure does not amount to a major failure.

For further details please visit [www.haymanreese.com.au/warranty](http://www.haymanreese.com.au/warranty) or contact customer service on 1800 812 017 or [info@haymanreese.com.au](mailto:info@haymanreese.com.au).



# CUSTOMER INFORMATION

PLACE THESE INSTRUCTIONS IN THE VEHICLE'S GLOVEBOX AFTER INSTALLATION

## HAYMAN REESE SMART PIN

Your Hayman Reese towbar is equipped with Smart Pin technology to help reduce towbar tongue rattle in most driving conditions. Please ensure below instructions are understood and routine maintenance is carried out to ensure best towing experience.

**i** Regularly inspect for wear and check the tightness of the Smart Pin Nut. Follow instructions below to re-tighten the nut as necessary when movement and noise in the tow ball mount is noted.

- Before towing, ensure R-Clip is properly installed and Smart pin nut is installed and tensioned. Replacement parts are available from your Hayman Reese Distributor.

## TOWBALL MOUNT REMOVAL/INSTALLATION

### STEP 1

Insert Trailer Ball Mount (TBM) (a) into towbar hitchbox (b), aligning hole in TBM shank (c) with hole in hitchbox (d) (Fig. 1)

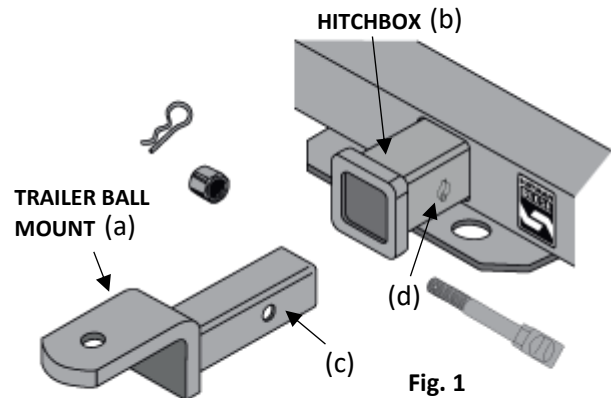

### STEP 2

Insert Smart Pin (e) through hole in hitchbox and hole in TBM shank (g); ensure the locators are inserted into the notches in the hitchbox (Fig. 2)

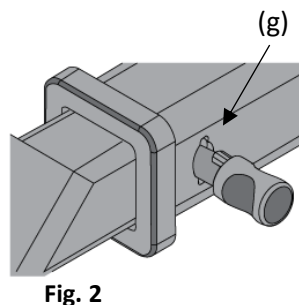

### STEP 3

Screw Smart Pin Nut (f) onto Smart Pin (g); tighten Smart Pin Nut until finger tight, ensuring TBM is restrained from up and down movement.

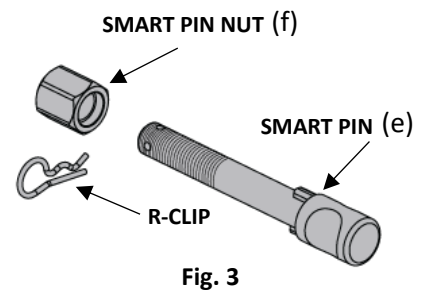

### STEP 4

Tighten Smart Pin Nut by turning nut a further 1/8th of a turn in the clockwise direction using a 24mm spanner (Fig. 4).

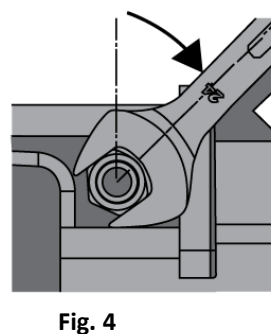

### STEP 5

Install Smart Pin R-Clip through the hole that provides best clearance or easiest access. (Fig. 5)

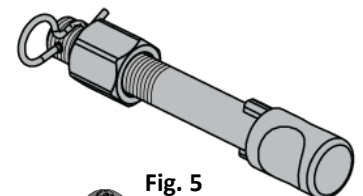

### STEP 6

Install towball onto TBM and tighten to **350 Nm** using a calibrated torque wrench (Fig. 6).

