

# TRAILBOSS

## Towbar Fitting Instructions To Suit **MITSUBISHI OUTLANDER MY13 2013 ON** Part Number **CL84L** Rating **1600/160 kg**

PLACE THESE INSTRUCTIONS IN THE VEHICLE'S GLOVEBOX AFTER INSTALLATION IS COMPLETE

### **WARNING:**

1. Do not, drill, cut, weld or otherwise modify the tow bar.
2. If you are using electric welding on a motor vehicle, **always** check that the vehicle is not equipped with electronic engine or instrument management equipment. Failure to do so could **destroy** any onboard computers. If in doubt, check with the vehicle's manufacturer.
3. The high tensile fasteners supplied with this product were used to achieve the specified rating. If replacement is required ensure that fasteners of the same rating & quality are used. Contact an authorised **Trailboss** dealer if further information is required.

### **General:**

1. Ensure all hardware items have been included refer to assembly diagram.
2. It is recommended that the instructions are read through and completely understood before making any attempt to fit this product.
3. Be wary of any changes to vehicle designs or other accessories that may conflict with the installation of this product.
4. Before drilling ensure that the area is clear of fuel, electrical & other components.
5. All holes drilled into the body panels shall have all burrs & swarf removed then coated with a suitable rust preventative paint.
6. For vehicles that require the bumper to be cut. Ensure cut out area is in correct position on the vehicle prior to cutting the bumper.
7. The high tensile fasteners supplied with this product were used to achieve the specified rating. If replacement is required ensure that fasteners of the same rating & quality are used. Contact an authorized **Trailboss** dealer if further information is required.
8. Ensure that all hardware is fastened to torque list below check fasteners on regular basis.
9. Tow bar load rating sticker provided with this product shall be conspicuously located on inside rear end of the driver's door. **(See diagram below)**.
10. Trailboss recommends that you check your tow ball to ensure that it complies with the Australian standards **AS 4177.2**.
11. **PLEASE NOTE:** It is advised to remove your lug or tbm when not actually towing so as to produce a clear view of the vehicles registration plate if obscured, and to also provide maximum available departure angle
12. Pull Pin must be fit in down position.

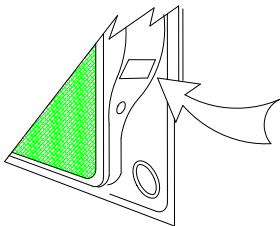

Place load rating sticker  
inside driver's door here

**FOR TRAILER TOWING PURPOSES ONLY**  
For towing capacity details please refer to vehicle owner's manual or to the manufacturer. Overloading can void your warranties.

### **RECOMMENDED ASSEMBLY TORQUE LISTING**

<u>Diameter</u>	<u>Grade 8.8 Bolt</u>
M6	9.5 Nm
M8	21.7 Nm
M10	43.4 Nm
M12	77.3Nm
M14	146 Nm
M16	189.8 Nm

### **Tow bar Maintenance and Care.**

Trailboss recommends that bolt torque's, as listed below, are routinely and regularly inspected and checked for correct tension. Replace any worn or defective parts.

We recommended to remove Tow Ball Mounts (TBM's, tongues or lugs) when not being used for any considerable length of time.

So as to avoid injury, when not towing it is suggested that the tongue, Pull Pin and R-clip are removed then stored in a safe, clean and dry place, away from excessive moisture.

Hitch Pull Pins and spring "R" clips are regularly checked for proper installation. Replace any worn or defective parts.

# TRAILBOSS

Towbar Fitting Instructions  
 To Suit **MITSUBISHI OUTLANDER MY13 2013 ON**  
 Part Number **CL84L**  
 Rating **1600/160 kg**

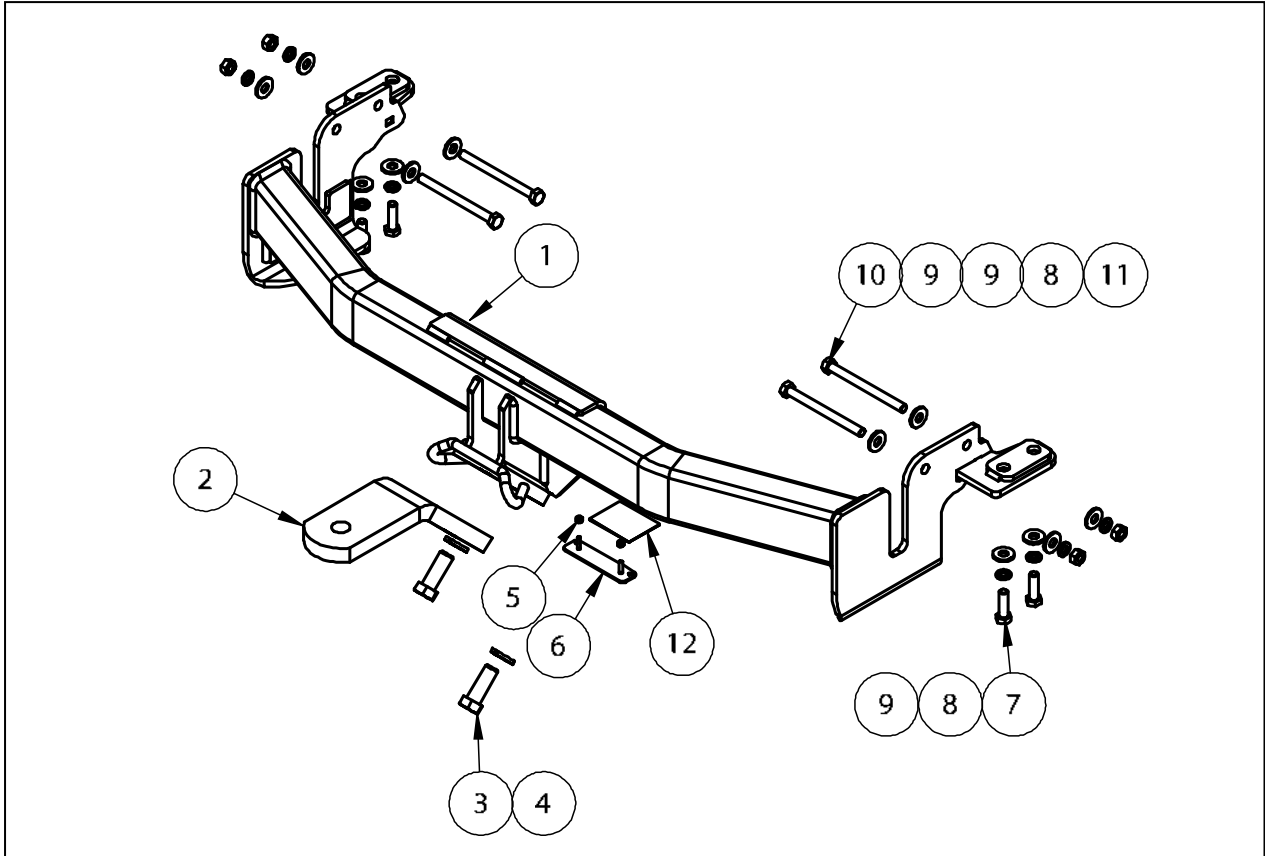

QTY	DESCRIPTION	ITEM NO
1	WELDED ASSEMBLY	1
1	LUG	2
2	M16X5X3.5 SPRING WASHER	3
2	M16X45 2.0P BOLT	4
2	NUT NYLOC M4-0.7 Z/P	5
1	PLUG BRACKET	6
4	SET SCREW HEX HD M10X35X1.25P	7
8	M10X3.5X2.2 SPRING WSHR	8
12	WSHR FT M10X25.4X3	9
4	M10-1.5X120mm BOLT	10
4	HEX NUT M10X1.5	11
1	COMPLIANCE PLATE	12

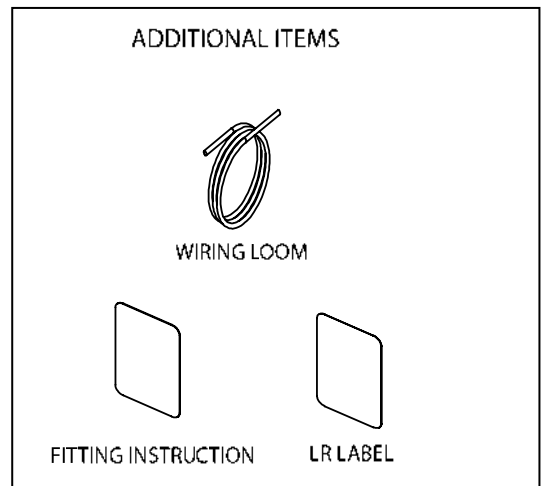



Towbar Fitting Instructions  
To Suit **MITSUBISHI OUTLANDER MY13 2013 ON**  
Part Number **CL84L**  
Rating **1600/160 kg**

PLACE THESE INSTRUCTIONS IN THE VEHICLE'S GLOVEBOX AFTER INSTALLATION IS COMPLETE

**INSTRUCTION:**

1. Remove 2xScrews from each side to remove Rear Tail Light. Some force may be required to the remove the Tail Light. Unplug the Connectors. Store them in a safe place.
2. Remove 2xM6 Bolts from the Boot Cavity from each side to remove Rear Bumper.  
Remove the Rubber Stopper by removing 2xM6 Bolts from both sides.
3. Remove 3xScrew Scrivets from the Wheel Arch from each side.
4. Remove 1xScrivet from inside the Wheel Arch from both sides.
5. Remove 1xScrivet from underneath the Bumper and Wheel Arch from both sides.
6. Remove 2xScrivets from underneath the Bumper. Flex the Bumper at the sides then pull rearwards to remove, some force may be required. Store the Bumper in a safe Location after removal.
7. Remove the Impact Beam or Stopper Via 3xBolts behind the Rear Panel from each side and discard them.
8. Remove the Shipping Hook via 3xBolts and discard them as well.
9. Lower the Exhaust to gain better access.
10. Fit the Towbar to the Chassis Rail ;  
Use 4xM10x120mm Bolt with M10Spring Washer, Flat Washer and Nut mount onto the side of Chassis Rails.  
Use 4xM10x35mm Set Screw with M10 Flat Washer, Spring Washer mount to the bottom of the Chassis Rail.
11. Torque all fasteners to specification on page1.
12. Cut 90mm Wide from the Centre line of the Bumper ,75mm Deep from the Bottom edge of the Bumper ,Mark out all lines .Neatly Cut Out ,using a Saw or Similar device to remove all burrs.
13. Refit the Bumper in reverse order from 1-6.





Wiring Loom Fitting Instructions  
To Suit Mitsubishi Outlander MY13  
Part Number 100893-WL

## Wiring Loom Installation Instructions

Mitsubishi Outlander MY13  
Part No: 100893-WL  
ECU Required: 04826

Tail Harness Length Required: 1800mm

Wiring Loom Installation Time: Approx 20 Mins

## Wiring Loom Fitting Instructions To Suit Mitsubishi Outlander MY13 Part Number 100893-WL

1. In the luggage compartment, remove the floor carpet cover.
2. Remove the six screws securing the luggage compartment storage tray.
3. Remove the luggage compartment storage tray.
4. Remove the rear luggage compartment trim by pulling in an upwards direction.
5. Fold the LHS rear seat base forward.
6. Remove the LHS rear floor trim
7. On the LHS of the luggage compartment, remove the four screws securing the luggage compartment trim.
8. Dislodge the LHS luggage compartment trim.
9. On the LHS rear quarter panel, drill a Ø30mm hole (1).



10. File any rough or sharp edges and spray on rust inhibitor.
  11. On the RHS of the luggage compartment, locate the break out connector and connect the trailer patch.
  12. Remove the foam block.
  13. Apply double sided tape to the ECU (04826) and secure it to the vehicle sheet metal where the foam block was previously located.
  14. Connect the trailer patch 12-way connector to the ECU (04826). Replace the foam block.
- Note: Ensure the ECU connector is facing downwards.**
15. Connect the trailer patch ground ring terminal to the vehicle grounding point.



Wiring Loom Fitting Instructions  
To Suit Mitsubishi Outlander MY13  
Part Number 100893-WL

16. In the engine bay near the battery, un-tape the vehicle harness break-out connector and connect the 4-way engine harness connector.
17. Route the engine harness ring terminal branch following the existing vehicle harness to the battery and secure to the positive battery terminal.
18. Mount the trailer socket to the tow bar mounting bracket using M4 fasteners (not supplied).
19. Route the tail harness (tail length: 1800mm) across the tow bar towards the LHS of the vehicle and up through the previously drilled out hole.
20. Ensure the tail harness grommet is seated correctly and secure in place using a cable tie (not supplied).
21. Connect the tail harness 8-way connector to the trailer wiring harness mating 8-way connector.
22. Test the trailer wiring harness function using a light board or multi meter.
23. Secure all harnesses using cable ties (not supplied).
24. Re-fit all removed parts and secure all fasteners, ensuring there are no squeaks or rattles.
25. Place the fitting instructions in the glove box after fitment.