

# TRAILBOSS

## Towbar Fitting Instructions To Suit **MITSUBISHI LANCER 09/2012-** on Part Number **CL85L** Rating **1000/100 kg**

PLACE THESE INSTRUCTIONS IN THE VEHICLE'S GLOVEBOX AFTER INSTALLATION IS COMPLETE

### **WARNING:**

1. Do not, drill, cut, weld or otherwise modify the tow bar.
2. If you are using electric welding on a motor vehicle, **always** check that the vehicle is not equipped with electronic engine or instrument management equipment. Failure to do so could **destroy** any onboard computers. If in doubt, check with the vehicle's manufacturer.
3. The high tensile fasteners supplied with this product were used to achieve the specified rating. If replacement is required ensure that fasteners of the same rating & quality are used. Contact an authorised **Trailboss** dealer if further information is required.

### **General:**

1. Ensure all hardware items have been included refer to assembly diagram.
2. It is recommended that the instructions are read through and completely understood before making any attempt to fit this product.
3. Be wary of any changes to vehicle designs or other accessories that may conflict with the installation of this product.
4. Before drilling ensure that the area is clear of fuel, electrical & other components.
5. All holes drilled into the body panels shall have all burrs & swarf removed then coated with a suitable rust preventative paint.
6. For vehicles that require the bumper to be cut. Ensure cut out area is in correct position on the vehicle prior to cutting the bumper.
7. The high tensile fasteners supplied with this product were used to achieve the specified rating. If replacement is required ensure that fasteners of the same rating & quality are used. Contact an authorized **Trailboss** dealer if further information is required.
8. Ensure that all hardware is fastened to torque list below check fasteners on regular basis.
9. Tow bar load rating sticker provided with this product shall be conspicuously located on inside rear end of the driver's door. **(See diagram below)**.
10. Trailboss recommends that you check your tow ball to ensure that it complies with the Australian standards **AS 4177.2**.
11. **PLEASE NOTE:** It is advised to remove your lug or tbm when not actually towing so as to produce a clear view of the vehicles registration plate if obscured, and to also provide maximum available departure angle
12. Pull Pin must be fit in down position.

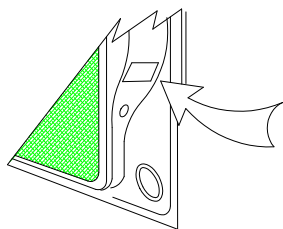

Place load rating sticker  
inside driver's door here

**FOR TRAILER TOWING PURPOSES ONLY**  
For towing capacity details please refer to vehicle owner's manual or to the manufacturer. Overloading can void your warranties.

#### RECOMMENDED ASSEMBLY TORQUE LISTING

Diameter	Grade 8.8 Bolt
M6	9.5 Nm
M8	21.7 Nm
M10	43.4 Nm
M12	77.3Nm
M14	146 Nm
M16	189.8 Nm

### **Tow bar Maintenance and Care.**

Trailboss recommends that bolt torque's, as listed below, are routinely and regularly inspected and checked for correct tension. Replace any worn or defective parts.

We recommended to remove Tow Ball Mounts (TBM's, tongues or lugs) when not being used for any considerable length of time.

So as to avoid injury, when not towing it is suggested that the tongue, Pull Pin and R-clip are removed then stored in a safe, clean and dry place, away from excessive moisture.

Hitch Pull Pins and spring "R" clips are regularly checked for proper installation. Replace any worn or defective parts.

# TRAILBOSS

Towbar Fitting Instructions  
 To Suit **MITSUBISHI LANCER 09/2012-** on  
 Part Number **CL85L**  
 Rating **1000/100 kg**

PLACE THESE INSTRUCTIONS IN THE VEHICLE'S GLOVEBOX AFTER INSTALLATION IS COMPLETE

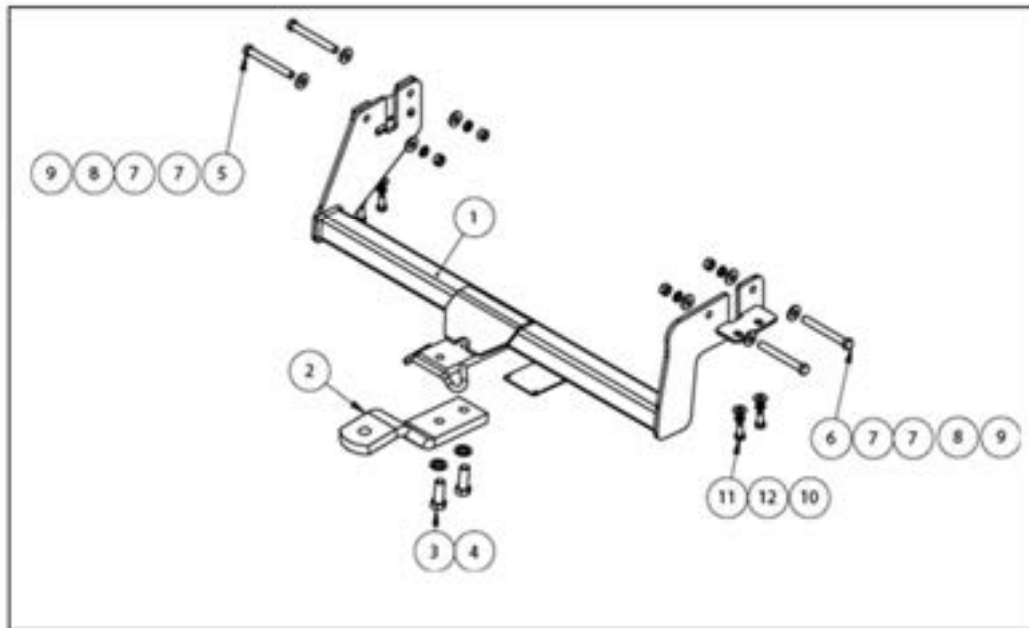

QTY.	DESCRIPTION	ITEM NO.
1	WELDED ASSEMBLY	1
1	LUG	2
2	M16x45 2.0P BOLT	3
2	M16x5x3.5 SPRING WASHER	4
2	M12x130 BOLT	5
2	M12x110 BOLT	6
8	WASHER M12x28.8x3mm	7
4	Wshr SPRING FT SEC M12x4.0x2.5mm Z/P	8
4	M12x1.75 HEX NUT PC8	9
4	WASHER FLAT M10x23x2 Z/P	10
4	BOLT M10x1.25x25	11
4	M10x3.5x2.2 SPRING WSHR	12

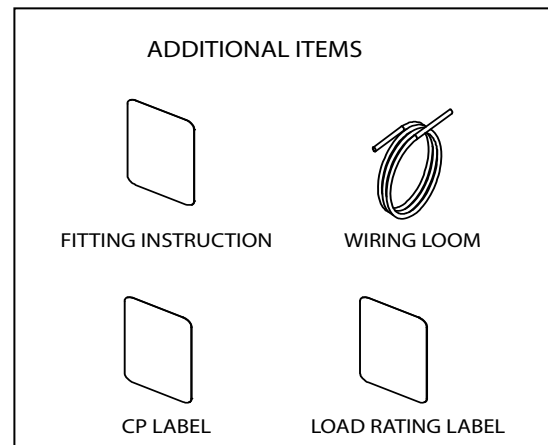



Towbar Fitting Instructions  
To Suit **mitsubishi LANCER 09/2012-** on  
Part Number **CL85L**  
Rating **1000/100 kg**

PLACE THESE INSTRUCTIONS IN THE VEHICLE'S GLOVEBOX AFTER INSTALLATION IS COMPLETE

**INSTRUCTION:**

1. Remove 2 M6 Bolts from each side of the Boot Cavity.
2. Remove 2 Scrivets from the Wheel Arch, one from each side. Remove 4 M6 Bolts from Wheel Arch, two from each side.
3. Remove 2 M6 Bolts from inside the Wheel Arch, repeat at the other side of vehicle.
4. Remove 2 Plastic Trim Plugs from inside and outside of the Mud Guard (If applicable); same to the other side of vehicle.
5. Remove 4 Rubber Plug, two from each side after the removal of Mud Guard.
6. Remove 2 Plastic Trim Buttons from the bottom of the Bumper.  
Note: Disconnect any Wiring (reverse Sensor) from the Bumper. Flex Bumper out at the sides then Pull rearward to remove, some force may be required .Store the Bumper in a safe location  
**CAUTION -TWO PERSON LIFT REQUIRED**
7. Lower the Rear Muffler via 3 Rubber Hangers to gain better access.
8. Offer Towbar to vehicle sub frame so that holes in side tabs align with M10 Captive Nuts in underside of vehicle Chassis.  
Fit Loosely the M10x25 Bolts supplied through slots in the Towbar into Captive Nuts located on the underside of the Chassis Rails.
9. Align horizontal Holes in side Plates with the Captive Bushes on the horizontal face of the Vehicle chassis rails.  
Use the Packer on the Passenger side as shown in the assembly drawing in page 3.
10. Feed M12x110 Bolts with Flat and Spring Washers through outer face of Chassis Rails in four Places ensuring that a Flat Washer is placed on the inner face of the Head of the Bolt.
11. Tighten all fasteners to Torque specifications provided.
12. Ensure to lift the Exhaust System into place.
13. Refit the Bumper in the reverse order of removal.



Wiring Loom Fitting Instructions  
To Suit Mitsubishi Lancer Hatch MY13  
Part Number 101028-WL

**Wiring Loom Installation Instructions**

**Mitsubishi Lancer Hatch MY13  
Part No: 101028-WL**

**Tail Harness Length Required: 1200mm  
ECU Required: 04826**

**Wiring Loom Installation Time: Approx 45 Mins**



Wiring Loom Fitting Instructions  
To Suit Mitsubishi Lancer Hatch MY13  
Part Number 101028-WL

1. In the luggage compartment, remove the parcel shelf.
2. Remove the carpet cover.
3. Fold down the rear seats.
4. Remove the two rear fasteners.
5. Remove the rear luggage compartment trim.
6. Remove the three fasteners and remove the plastic trim.
7. On the LHS of the luggage compartment, remove the storage cover by removing the screw.
8. Remove the three screws on the luggage compartment trim .
9. Remove the luggage compartment trim.

**Repeat for the RHS.**

10. Remove the LHS rear door trim.
11. Remove the LHS passengers door trim and the kick panel trim.
12. On the LHS of the rear quarter panel, drill a Ø30mm hole on the indicated location.
13. On the RHS of the luggage compartment, connect the 2-way trailer patch connector to its mating 2-way vehicle tail light assembly connectors.
14. Route the trailer patch towards the LHS of the vehicle.
15. On the LHS of the luggage compartment, connect the 2-way & 3-way trailer patch connector to its mating 2-way & 3-way vehicle tail light assembly connectors.
16. On the LHS of the luggage compartment, connect the trailer patch 12-way connector to the ECU (04826).
17. Apply double sided tape to the ECU and adhere it to the vehicle sheet metal in a suitable location.

## Wiring Loom Fitting Instructions To Suit Mitsubishi Lancer Hatch MY13 Part Number 101028-WL

18. Following the table below, connect the ezy-tap (1) to the LIGHT BLUE wire (2), then connect the terminal (3) to the ezy-tap (1).

19. Connect the trailer patch ring terminal (4) to the existing vehicle grounding point.



Function	Trailer Patch	Vehicle Connector
REVERSE	BLACK / WHITE	LIGHT BLUE

20. In the glove box area, remove the 20-amp fuse (1).

21. Insert the previously removed 20-amp fuse (2) into the supplied add-a-fuse harness (3) lower slot as shown.

22. Insert the 20-amp fuse (4) into the supplied add-a-fuse harness (3) upper slot as shown.

23. Connect the trailer patch 1-way connector (5) to the add-a-fuse harness (3).

24. Connect the add-a-fuse harness (3) into the fuse panel now vacant fuse location in the orientation shown.

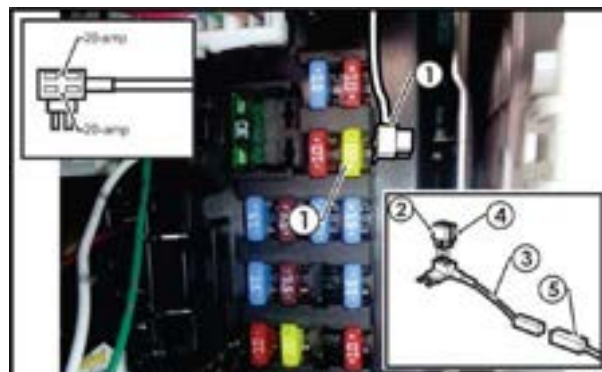



Wiring Loom Fitting Instructions  
To Suit Mitsubishi Lancer Hatch MY13  
Part Number 101028-WL

25. Mount the tail harness socket to the towbar mounting bracket using M4 fasteners (not supplied).
26. Route the tail harness towards the LHS, up through the previously drilled grommet hole.
27. Ensure the tail harness grommet is seated correctly and secured in place using a cable tie (not supplied).
28. Connect the tail harness (tail length 1200mm) 8-way connector to the trailer harness mating 8-way connector.
29. Test the trailer patch function using a lightboard or multimeter.
30. Secure all harnesses using cable ties (not supplied).
31. Re-fit all removed parts and secure all fasteners, ensuring there are no squeaks or rattles.
32. Place the fitting instructions in the glove box after fitment.