

TRAILBOSS

Towbar Fitting Instructions To Suit **NISSAN PULSAR 2013 ON** Part Number **DS100L** Rating **1200/120 kg**

PLACE THESE INSTRUCTIONS IN THE VEHICLE'S GLOVEBOX AFTER INSTALLATION IS COMPLETED

WARNING:

1. Do not, drill, cut, weld or otherwise modify the tow bar.
2. If you are using electric welding on a motor vehicle, **always** check that the vehicle is not equipped with electronic engine or instrument management equipment. Failure to do so could **destroy** any onboard computers. If in doubt, check with the vehicle's manufacturer.
3. The high tensile fasteners supplied with this product were used to achieve the specified rating. If replacement is required ensure that fasteners of the same rating & quality are used. Contact an authorised **Trailboss** dealer if further information is required.

General:

1. Ensure all hardware items have been included refer to assembly diagram.
2. It is recommended that the instructions are read through and completely understood before making any attempt to fit this product.
3. Be wary of any changes to vehicle designs or other accessories that may conflict with the installation of this product.
4. Before drilling ensure that the area is clear of fuel, electrical & other components.
5. All holes drilled into the body panels shall have all burrs & swarf removed then coated with a suitable rust preventative paint.
6. For vehicles that require the bumper to be cut. Ensure cut out area is in correct position on the vehicle prior to cutting the bumper.
7. The high tensile fasteners supplied with this product were used to achieve the specified rating. If replacement is required ensure that fasteners of the same rating & quality are used. Contact an authorized **Trailboss** dealer if further information is required.
8. Ensure that all hardware is fastened to torque list below check fasteners on regular basis.
9. Tow bar load rating sticker provided with this product shall be conspicuously located on inside rear end of the driver's door. **(See diagram below)**.
10. Trailboss recommends that you check your tow ball to ensure that it complies with the Australian standards **AS 4177.2**.
11. **PLEASE NOTE:** It is advised to remove your lug or tbm when not actually towing so as to produce a clear view of the vehicles registration plate if obscured, and to also provide maximum available departure angle
12. Pull Pin must be fit in down position.

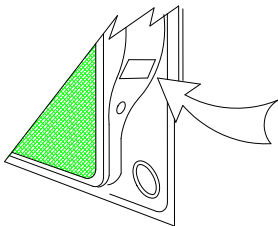

Place load rating sticker
inside driver's door here

FOR TRAILER TOWING PURPOSES ONLY
For towing capacity details please refer to vehicle owner's manual or to the manufacturer. Overloading can void your warranties.

RECOMMENDED ASSEMBLY TORQUE LISTING

<u>Diameter</u>	<u>Grade 8.8 Bolt</u>
M6	9.5 Nm
M8	21.7 Nm
M10	43.4 Nm
M12	77.3Nm
M14	146 Nm
M16	189.8 Nm

Tow bar Maintenance and Care.

Trailboss recommends that bolt torque's, as listed below, are routinely and regularly inspected and checked for correct tension. Replace any worn or defective parts.

We recommended to remove Tow Ball Mounts (TBM's, tongues or lugs) when not being used for any considerable length of time.

So as to avoid injury, when not towing it is suggested that the tongue, Pull Pin and R-clip are removed then stored in a safe, clean and dry place, away from excessive moisture.

Hitch Pull Pins and spring "R" clips are regularly checked for proper installation. Replace any worn or defective parts.

TRAILBOSS

Towbar Fitting Instructions
 To Suit **NISSAN PULSAR 2013 ON**
 Part Number **DS100L**
 Rating **1200/120 kg**

PLACE THESE INSTRUCTIONS IN THE VEHICLE'S GLOVEBOX AFTER INSTALLATION IS COMPLETED

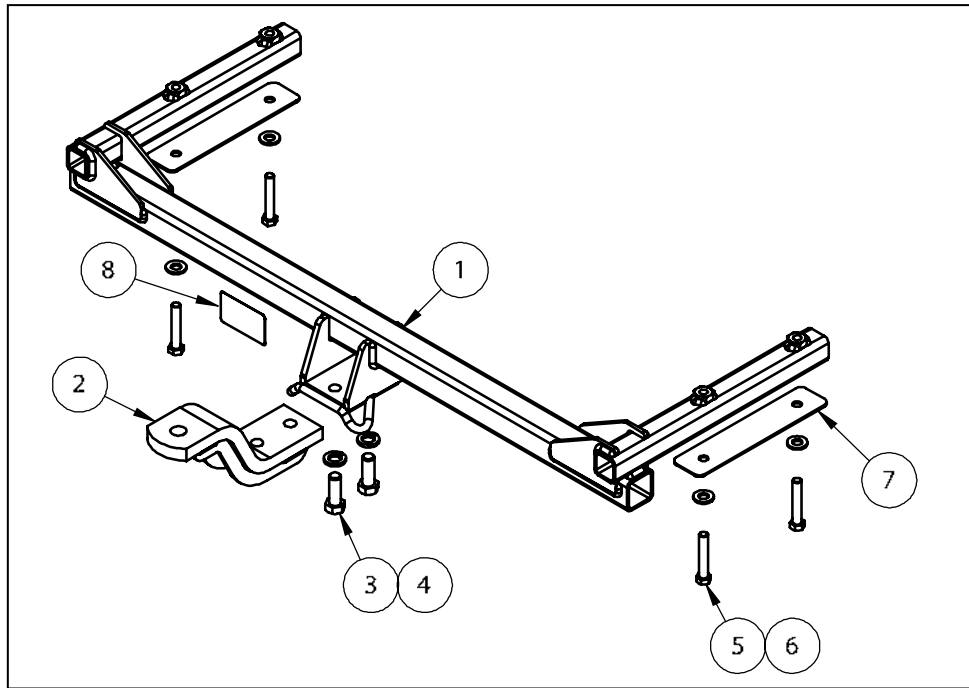

QTY	DESCRIPTION	ITEM NO
1	NISSAN PULSAR MY13 ASSEMBLY	1
1	REINFORCED LUG	2
2	M16x45 2.0P BOLT	3
2	M16x5x3.5 SPRING WASHER	4
4	M12x60x1.25P BOLT	5
4	1/2" x 1-1/8" FLAT WASHER	6
2	WASHER PLATE	7
1	ACRYLIC CP LABEL	8

ADDITIONAL ITEMS

WIRING LOOM FITTING INSTRUCTION LR LABEL

PLUG BRACKET NUT NYLOC



Towbar Fitting Instructions
To Suit **NISSAN PULSAR 2013 ON**
Part Number **DS100L**
Rating **1200/120 kg**

PLACE THESE INSTRUCTIONS IN THE VEHICLE'S GLOVEBOX AFTER INSTALLATION IS COMPLETED

INSTRUCTION:

1. Remove 3x Screws inside both Rear Wheel arches.
2. Remove 1x Screw on the underside of both Rear Wheel arches.
3. Remove 2x Scrivets on the rear underside of the Bumper.
4. Pull back internal Boot Trim Panel as shown and remove 2x Nuts on both sides.
5. Remove Rear Lights by firmly pulling backwards.
6. Remove 1x Scrivet & 1x Screw on topside of Bumper behind lights.
7. Remove rear Bumper by unclipping both sides and firmly pulling backwards.
8. Remove both Impact Cones covering Chassis Rail ends by unscrewing 2x Bolts on both sides.
9. Cut the back panel out as shown in Figure 1, using outer panel shape of the chassis rail as a guide template.
10. Drill both the forward and rear most holes shown in Figure 2, out to 13mm (1/2") - if needed use the washer plate in the bolt kit to identify correct holes.
11. Insert Towbar into Chassis Rails and bolt up using 4x M12x70 Bolts, Flat Washers and Washer Plates provided in the Bolt Pack. Remembering to torque the bolts to the correct settings provided at the start of the fitting instructions.
12. Re-fit all necessary components in reverse order.



Figure 1



Figure 2



Wiring Loom Fitting Instructions
To Suit Nissan Pulsar
Part Number 100937-WL

Wiring Loom Installation Instructions

Nissan Pulsar
Part No: 100937-WL

Tail Harness Length Required: 1800mm

Wiring Loom Installation Time: Approx 15 Mins



Wiring Loom Fitting Instructions
To Suit Nissan Pulsar
Part Number 100937-WL

1. In the luggage compartment, remove the floor carpet cover.
2. Remove the rear luggage compartment trim by first removing the two clips and pulling in an upwards direction.
3. On the LHS of the luggage compartment, dislodge the luggage compartment trim by first removing the clip and pulling towards the centre of the vehicle.

Repeat for the RHS.

4. Disconnect the LHS tail light connectors and patch the trailer patch connectors in between.
5. Route the trailer patch along the rear luggage compartment towards the RHS of the vehicle.
6. Disconnect the RHS tail light connectors and patch the trailer patch connectors in between.
7. Secure the trailer patch ground ring terminal to the sheet metal using a tek screw.
8. Route the trailer patch 8-way connector (1) towards the exiting vehicle grommet (2).

Note: If vehicle grommet is occupied, drill a Ø30mm hole (3) next to it.



9. Mount the trailer socket to the tow bar mounting bracket using M4 fasteners (not supplied).
10. Route the tail harness (tail length 1800mm) across the tow bar towards the RHS of the vehicle and up through the vehicle grommet or the previously drilled hole.
11. Ensure the tail harness grommet is seated correctly and secured in place using a cable tie (not supplied).
12. Connect the tail harness 8-way connector to the trailer patch 8-way mating connector.



Wiring Loom Fitting Instructions
To Suit Nissan Pulsar
Part Number 100937-WL

13. Test the trailer harness function using a Light Board or multimeter.
14. Secure all harnesses using cables ties (not supplied).
15. Re-fit all removed parts and secure all fasteners, ensuring there are no squeaks or rattles.
16. Place the instructions in the glove box after fitment.