



Towbar Fitting Instructions
To Suit NISSAN PULSAR SEDAN 07/2000- 01/2006
Part Number DS87
Rating 1000Kg

1. Ensure all hardware items have been included.
2. Remove rear bumper bar.
3. Remove crash cones from rear panel.
4. Remove and discard tow hook mounting bracket from inside of left hand side chassis rail.
5. Fit M10x30 bolt nut, flat washer and spring washer inside left hand chassis rail through vertical hole of shipping hook making sure bolt points down.
6. Fit towbar to rear of vehicle and loosely fit four M10 bolts as per diagram.
7. Refit previously removed crash cones with six M8x30 bolts as per diagram.
8. For vehicles from the 7th month of 2000 to 7th month of 2003 discard spacer plate and use M16 x 45 bolts, and see bumper cut fig 1.
9. For vehicles from the 7th month of 2003 –onwards, fit spacer plate and use M16 x 60 bolts, and see bumper cut fig 2.
10. Tighten all bolts to torque listing below.
11. Cut bumper as per diagram.
12. Refit bumper.

RECOMMENDED ASSEMBLY TORQUE LISTING

<u>Diameter</u>	<u>Grade 8.8 Bolt</u>
	Nm
M6	9.5
M8	21.7
M10	43.4
M12	77.3
M14	121.0
M16	189.8

TRAILBOSS

Towbar Fitting Instructions
 To Suit NISSAN PULSAR SEDAN 07/2000- 01/2006
 Part Number DS87
 Rating 1000Kg

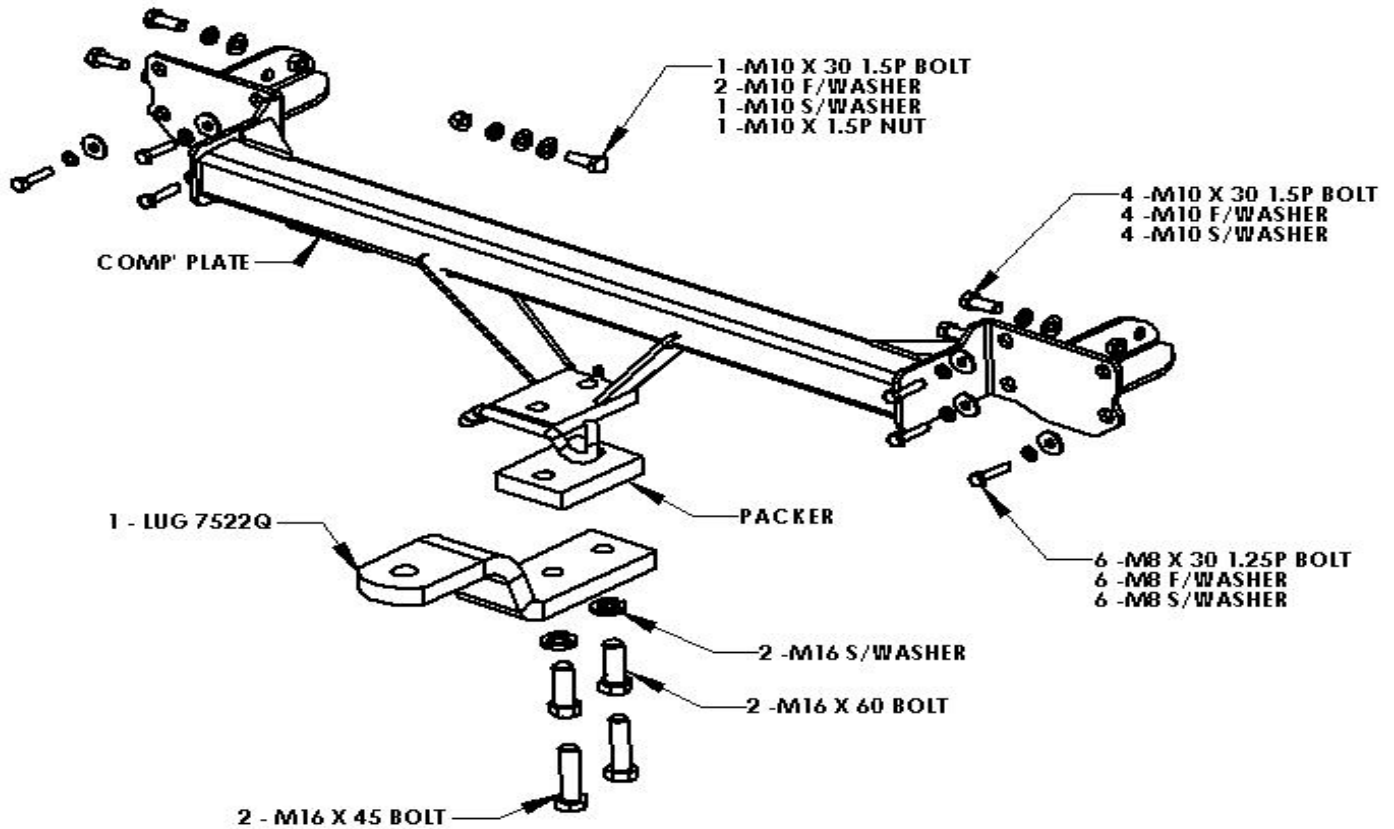

BUMPER CUT TO SUIT
 NISSAN PULSAR FROM
 7-2000 TO 7-2003

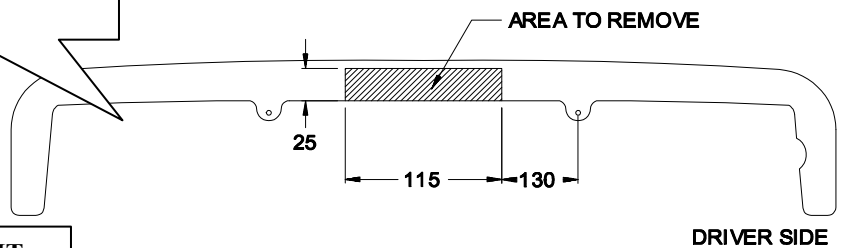

Fig 1

BUMPER CUT TO SUIT
 NISSAN PULSAR FROM
 7-2003-ON

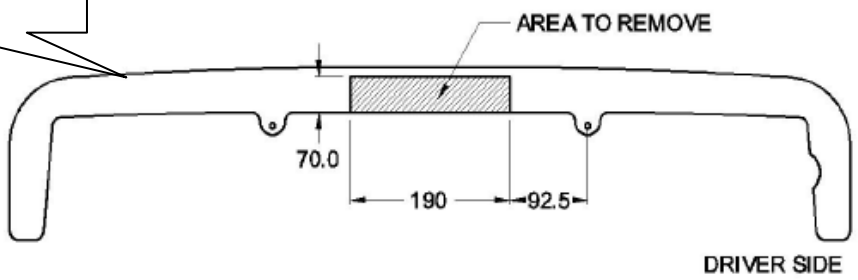

Fig 2