



Tow bar Fitting Instructions
To Suit Ford Focus 5 Door Hatch 05-05-on
Part Number FD123L
Rating 900Kg

WARNING:

1. Do not, drill, cut, weld or otherwise modify the Towbar.
2. If you are using electric welding on a motor vehicle, **always** check that the vehicle is not equipped with electronic engine or instrument management equipment. Failure to do so could **destroy** any onboard computers. If in doubt, check with the vehicle's manufacturer.

- 1 Ensure all hardware items have been included
- 2 Remove rear bumper bar via
 - a) Disconnect wiring loom on the driver's side.
 - b) Remove 2 x screws from under lid.
 - c) Remove 2 x plastic trim buttons from rear lower lip of bumper.
 - d) Remove 2 x torx screws from inner guard of bumper at each wheel arch.
 - e) Pull inner wheel arch forward to expose 6mm nuts and remove both sides.
- 3 Remove & discard impact beam
- 4 Fit side arms up the chassis rails and align with holes (note due to body variations some material removal may be required if Towbar is too tight).
- 5 Recoat any raw surfaces with suitable paint
- 6 Fit plates bolts & washers loosely as per the diagram on the next page.
- 7 Refit bumper in reverse of step 2.
- 8 Tighten all bolts to torque listing.

RECOMMENDED ASSEMBLY TORQUE LISTING

<u>Diameter</u>	<u>Grade 8.8 Bolt</u>
	Nm
M6	9.5
M8	21.7
M10	43.4
M12	77.3
M14	121.0
M16	189.8

FOR TOWING PURPOSES ONLY
For towing capacity details please refer to vehicle owner's manual or to the manufacturer. Overloading can void your warranties.

TRAILBOSS

Tow bar Fitting Instructions
To Suit Ford Focus 5 Door Hatch 05-05-on
Part Number FD123L
Rating 900Kg

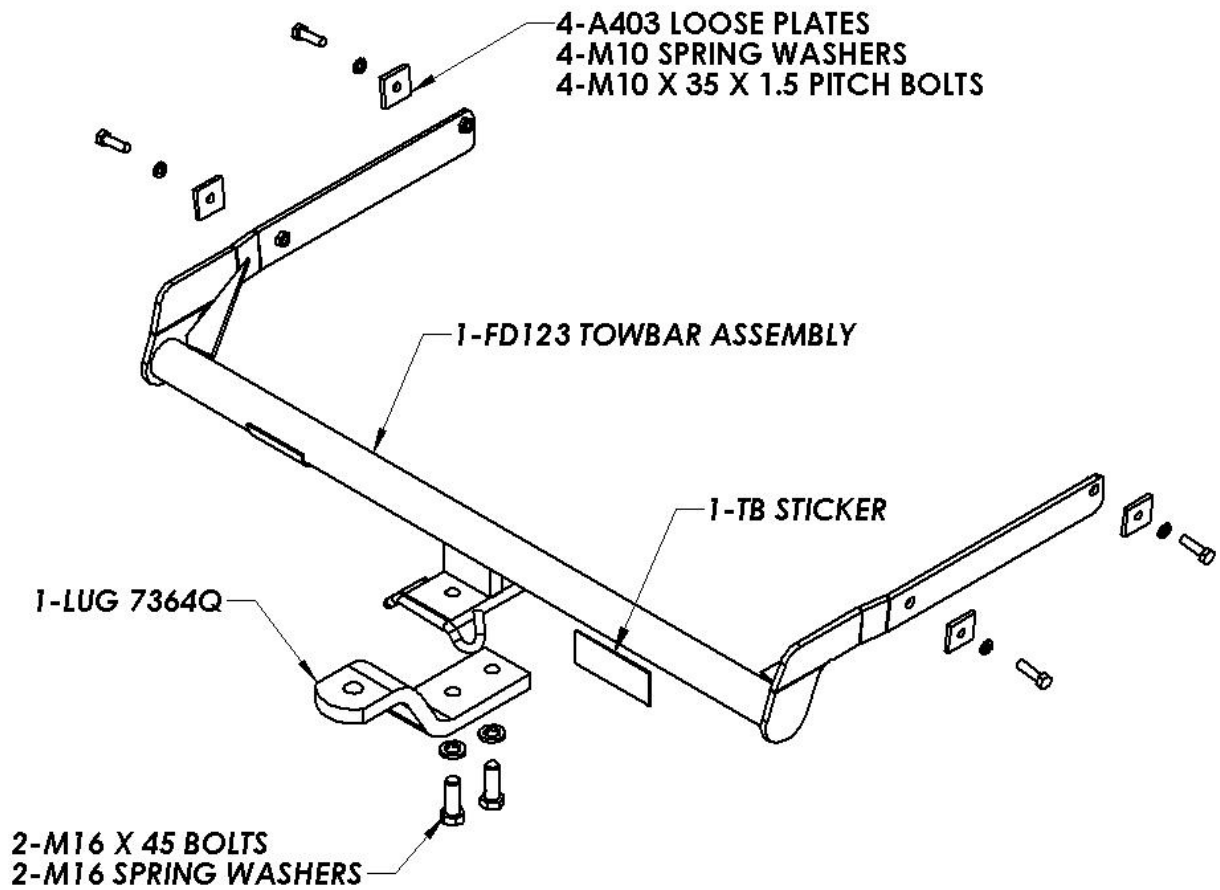



Wiring Loom Fitting Instructions
To Suit Ford Focus 5 Door
Part Number 100019-WL

Wiring Loom Installation Instructions

Ford Focus 5 Door
Part No: 100019-WL

Tail Harness Length Required: 1200mm
RPA Override Switch Part No: 04848 (If Fitted)

Wiring Loom Installation Time: Approx 30 Mins



Wiring Loom Fitting Instructions
To Suit Ford Focus 5 Door
Part Number 100019-WL

1. Remove all the required trims to gain access to the vehicle LHS and RHS rear quarters.
2. From underneath the vehicle, disconnect the LHS reverse light connectors.
3. In the LHS luggage compartment area, remove the reverse light grommet from the vehicle along with the reverse light connector.
4. Drill a Ø30mm hole into the vehicle below the existing LHS rear quarter grommet location. File down any rough edges and spray on rust inhibitor.
5. Route the Trailer Patch Harness (P/No: 100019-WL) into the existing grommet hole and then adjust the trailer patch grommet ensuring the vehicle grommet is seated correctly.
6. Connect the trailer patch 2-way connector into the vehicle harness 2-way reverse light connector.
7. From underneath the vehicle, connect the harness 2-way reverse connector to the vehicle reverse tail light.
8. Above the LHS rear wheel arch area, disconnect the tail light connectors and then patch the trailer patch harness connectors in between.
9. Route the RHS Trailer Patch Harness connectors along the rear following the vehicle harness towards the RHS tail light connectors and repeat the patching steps.
10. Mount the Tail Harness (tail length 1200mm) socket onto the towbar mounting bracket using M4 fasteners (not supplied) and then route the Tail Harness along the towbar and into the drilled out grommet.
11. Retrieve the Tail Harness 8-way male connector and connect it to the Trailer Patch Harness 8-way female connector.
12. From underneath the vehicle, adjust the Tail Harness grommet to the required length, ensuring it is seated correctly into the drilled out grommet hole. Secure the harness grommet using a cable tie (not supplied).
13. Secure the Trailer Patch Harness ground ring terminal to the vehicle grounding point located on the LHS rear quarter of the vehicle.
14. On the outside, secure the harness to the towbar using cable ties (not supplied).
15. Test the Trailer socket using a light board or multi-meter.
16. Secure the all harnesses using cables ties (not supplied).
17. Refit all removed parts and secure all fasteners.
18. Place instructions in glove box after fitment.