



**Towbar Fitting Instructions**  
 To Suit **FORD MONDEO SEDAN & HATCH 07/10-ON**  
 Part Number **FD133L**  
 Rating **1600 kg**

PLACE THESE INSTRUCTIONS IN THE VEHICLE'S GLOVEBOX AFTER INSTALLATION IS COMPLETE

**WARNING:**

1. Do not, drill, cut, weld or otherwise modify the tow bar.
2. If you are using electric welding on a motor vehicle, **always** check that the vehicle is not equipped with electronic engine or instrument management equipment. Failure to do so could **destroy** any onboard computers. If in doubt, check with the vehicle's manufacturer.

**General:**

1. Ensure all hardware items have been included refer to assembly diagram.
2. It is recommended that the instructions are read through and completely understood before making any attempt to fit this product.
3. Be wary of any changes to vehicle designs or other accessories that may conflict with the installation of this product.
4. Before drilling ensure that the area is clear of fuel, electrical & other components.
5. All holes drilled into the body panels shall have all burrs & swarf removed then coated with a suitable rust preventative paint.
6. The high tensile fasteners supplied with this product were used to achieve the specified rating. If replacement is required ensure that fasteners of the same rating & quality are used. Contact an authorized **Trailboss** dealer if further information is required.
7. Ensure that all hardware is fastened to torque list below check fasteners on regular basis.
8. Tow bar load rating sticker provided with this product shall be conspicuously located on inside rear end of the driver's door. **(See diagram below).**
9. Trailboss recommends that you check your tow ball to ensure that it complies with the Australian standards **AS 4177.2**.
10. **PLEASE NOTE:** It is advised to remove your lug or tbn when not actually towing so as to produce a clear view of the vehicles registration plate if obscured, and to also provide maximum available departure angle
11. Pull Pin must be fit in down position.
12. Place these instruction vehicle's glove box after installation is completed

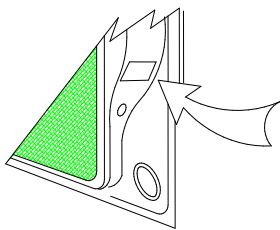

**Place load rating sticker inside driver's door here**

**FOR TRAILER TOWING PURPOSES ONLY**  
 For towing capacity details please refer to vehicle owner's manual or to the manufacturer. Overloading can void your warranties.

**RECOMMENDED ASSEMBLY TORQUE LISTING**

Diameter	Grade 8.8 Bolt
M6	9.5 Nm
M8	21.7 Nm
M10	43.4 Nm
M12	77.3Nm
M14	146 Nm
M16	189.8 Nm

**Tow bar Maintenance and Care.**

Trailboss recommends that bolt torque's, as listed below, are routinely and regularly inspected and checked for correct tension. Replace any worn or defective parts.  
 We recommended to remove Tow Ball Mounts (TBM's, tongues or lugs) when not being used for any considerable length of time.  
 So as to avoid injury, when not towing it is suggested that the tongue, Pull Pin and R-clip are removed then stored in a safe, clean and dry place, away from excessive moisture.  
 Hitch Pull Pins and spring "R" clips are regularly checked for proper installation. Replace any worn or defective parts.

# TRAILBOSS

Towbar Fitting Instructions  
 To Suit **FORD MONDEO SEDAN & HATCH 07/10-ON**  
 Part Number **FD133L**  
 Rating **1600 kg**

PLACE THESE INSTRUCTIONS IN THE VEHICLE'S GLOVEBOX AFTER INSTALLATION IS COMPLETE

**Note:**

This hole pattern is for the sedan variants  
 The other hole pattern is for the hatch back variant

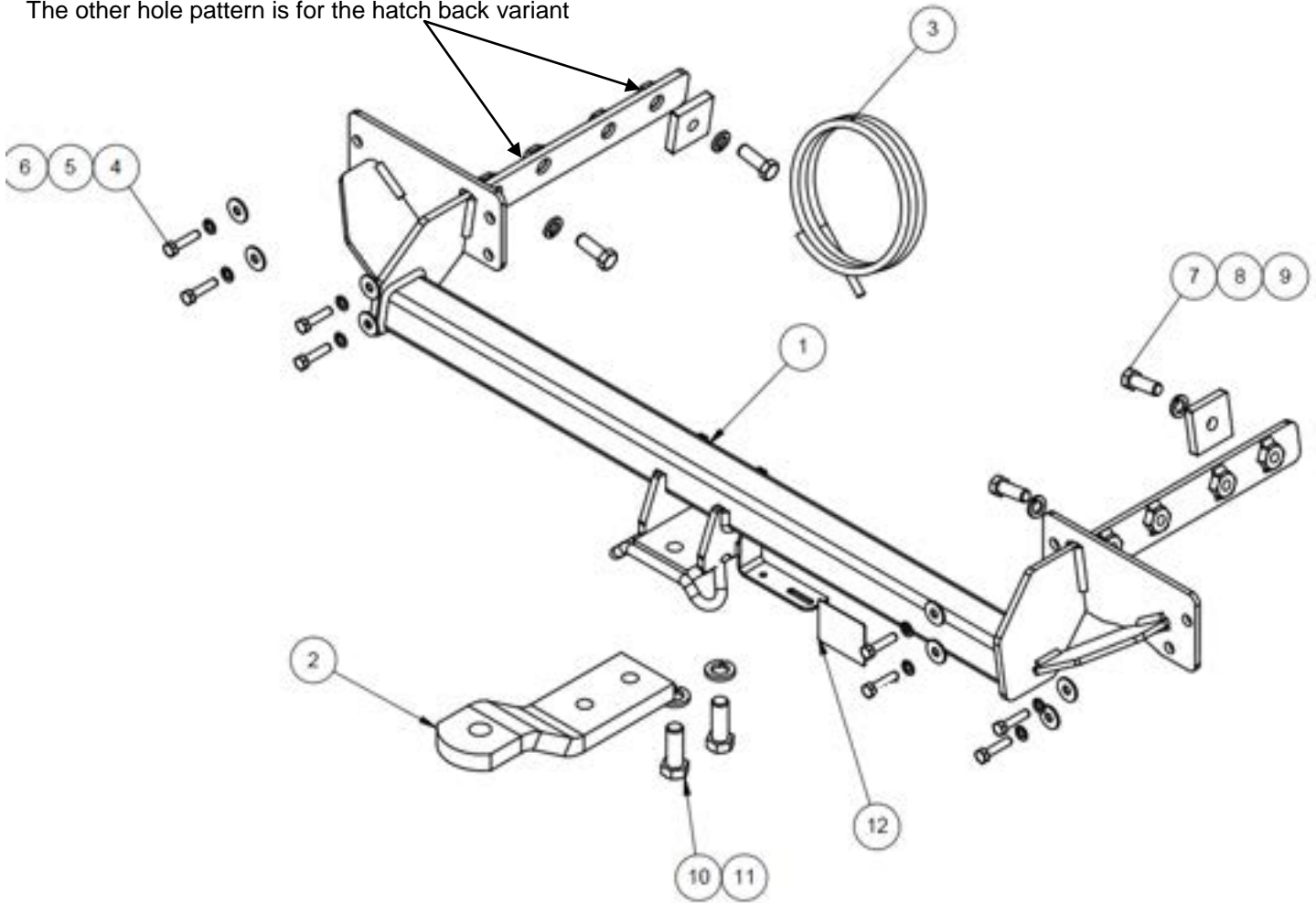

QTY	DESCRIPTION	ITEM ON.
1	WELDED ASSEMBLY	1
1	LUG 7691	2
1	WIRING LOOM	3
8	M8 X 30 HEX BOLT	4
8	M8 SPRING WASHERS	5
8	5/16 x7/8x16 FLAT WASHER	6
4	SET SCREW M12 x 35 x 1.75P	7
4	M12 SPRING WASHER	8
2	LOOSE PLATE	9
2	M16 x 45 HEX BOLT	10
2	M16 SPRING WASHER	11
1	COMPLIANCE PLATE LABEL	12



**Towbar Fitting Instructions**  
To Suit **FORD MONDEO SEDAN & HATCH 07/10-ON**  
Part Number **FD133L**  
Rating **1600 kg**

PLACE THESE INSTRUCTIONS IN THE VEHICLE'S GLOVEBOX AFTER INSTALLATION IS COMPLETE

1. **Remove rear bumper bar skin via**
  - a. Remove 2 x plastic trim buttons from the underside of the bumper bar.
  - b. Disconnect reverse parking assistance sensors if fitted.
  - c. From inside each wheel arch remove 3 x torx screws.
  - d. From inside rear boot cavity remove 2 x torx head screws.
  - e. Remove tail light via:
    - Remove cover trim to expose inner tail light cavities, So that access can be gained to remove 3x nuts on each side
    - Unplug tail light connector
    - Push the tab in upward direction to the tail light
  - f. Flex bumper bar skin out at the sides then pull rearward ensuring that bumper is perpendicular to the vehicle.
  - g. **Caution** two person lift is required some force may be required to remove bumper bar skin.
2. **Remove rear impact beam via**
  - a. Remove rear impact beam via seven bolts three on the passenger side & four on the driver's side.
  - b. Discard the impact beam & bolts.
3. **Lower rear muffler & heat shield**
  - a. Lower rear muffler from two rears most rubber exhaust hangers if twin mufflers are fitted repeat process for extra muffler.
  - b. Rubber hangers can be sprayed with CRC for ease of removal.
  - c. Remove one bolt & one fixing holding heat shield to underside of body so that heat shield can be lowered to gain better access to mounting points on chassis rails.
  - d. If twin mufflers are fitted lower both heat shields.
4. **Fitment of towbar via**
  - a. Offer towbar to the vehicle back panel so that holes in side plates align with M8 captive nuts on the back panel.
  - b. Fit M8 bolts with flat & spring washers provided loosely.
  - c. Then fit M12 bolts & spring washers through existing holes in the chassis rails so to align with captive nuts in chassis rail.
  - d. Ensure that the loose plate provided is fitted to the forward mount.
  - e. Fasten the M8 bolts to the torque listing first then fasten the M12 bolts to the torque listing.
  - f. Refit the heat shield & mufflers in the reverse of steps 3 d through to 3 a.
  - g. Mark out the bumper cut as shown below, Remove the wiring clips from the bumper which falls under the slot and relocate them.
  - h. Cut the underside of bumper bar, from center 140x150mm with R50mm radius.
  - i. Refit the rear bumper bar skin in the reverse of steps 1 f through to 1 a.



Towbar Fitting Instructions  
To Suit **FORD MONDEO SEDAN & HATCH 07/10-ON**  
Part Number **FD133L**  
Rating **1600 kg**

PLACE THESE INSTRUCTIONS IN THE VEHICLE'S GLOVEBOX AFTER INSTALLATION IS COMPLETE

**Bumper Cut**

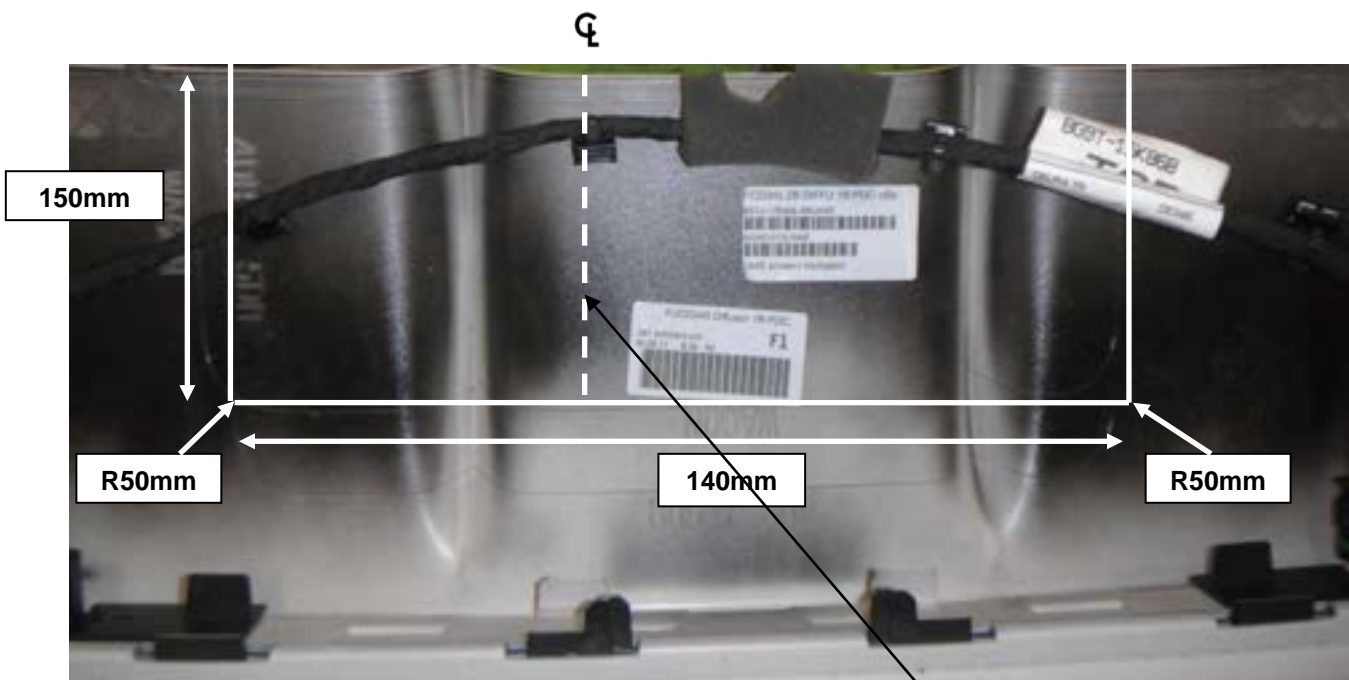

Establish centre line of bumper bar then measure from the centre out.



Wiring Loom Fitting Instructions  
To Suit Ford Mondeo Sedan Hatch  
Part Number 100770-WL

Wiring Loom Installation Instructions

Ford Mondeo Sedan Hatch  
Part No: 100770-WL

Tail Harness Length Required: 1200mm

**RPA can be disabled via the dashboard switch.**

Wiring Loom Installation Time: Approx. 30 Mins



Wiring Loom Fitting Instructions  
To Suit Ford Mondeo Sedan Hatch  
Part Number 100770-WL

1. In the luggage compartment, remove the parcel shelf.
2. Fold down the rear passenger seats.
3. Remove the smart key sensor whilst removing the luggage compartment tool storage.
4. Remove the spare wheel tyre from the luggage compartment.
5. Remove the rear luggage compartment trim by first removing the two scrivenets.
6. On the LHS of the rear passenger side, remove the lower 'C' pillar trim.
7. On the LHS of the luggage compartment, remove the upper compartment trim by first removing the two screws using a T25 torx screw bit.
8. Remove the luggage compartment trim by first removing the one scrivet.
9. On the LHS rear quarter panel, using a step drill, drill out the grommet hole below the fuse box to Ø30mm.
10. File down any rough edges and spray with rust inhibitor.
11. In the LHS of the luggage compartment, following the table below, connect the ezy-tap to the 'GREEN/BROWN' vehicle wire, and then connect the trailer patch terminal to the ezy-tap.

**Green Connector: Pin 4.**

Function	Trailer Patch	Vehicle Connector
REVERSE	BLACK / WHITE	GREEN / BROWN

12. Apply double sided tape to the ECU and adhere it to the vehicle sheet metal on the LHS rear quarter panel.
13. In the luggage compartment, connect the 12-way trailer harness connector to the ECU.
14. On the LHS of the luggage compartment, on the rear tail light, following the table below, connect the ezy-tap to the corresponding vehicle wires, and then connect the trailer patch terminal to the ezy-tap.

Function	Trailer Patch	Vehicle Connector
L.IND	YELLOW / BLACK	GREY / ORANGE
TAIL	BROWN / BLACK	PURPLE / GREEN
BRAKES	RED / BLACK	PURPLE / BROWN

15. Connect the trailer patch harness ground ring terminal to the vehicle grounding point.
16. Remove the black fuse cover and place in the tool storage tray.
17. Locate the vacant fuse slot.



Wiring Loom Fitting Instructions  
To Suit Ford Mondeo Sedan Hatch  
Part Number 100770-WL

18. Insert the supplied 20-amp fuse into the upper slot of the add-a-fuse harness.
19. Plug the add-a-fuse harness into the vacant fuse slot on the fuse panel.
20. Connect the 'ORANGE' power wire 1-way connector into the add-a-fuse harness mating connector.
21. Route the trailer patch harness (P/n: 100770-WL) from the LHS towards the RHS luggage compartment trim.
22. On the RHS of the luggage compartment trim, remove the access panel.
23. In the RHS of the luggage compartment, following the table below, connect the ezy-tap to the 'GREEN/ORANGE' vehicle wire, and then connect the trailer patch terminal to the ezy-tap.

Function	Trailer Patch	Vehicle Connector
R.IND	GREEN / BLACK	GREEN / ORANGE

24. Mount the trailer socket to the tow bar mounting bracket using M4 fasteners (not supplied).
25. Route the tail harness (tail length 1200mm) towards and up through the previously drilled out hole.
26. Ensure the tail harness grommet is seated correctly and makes a good seal.
27. Secure the grommet in place using a cable tie (not supplied).
28. Connect the Tail Harness 8-way connector to the Trailer Patch 8-Way mating connector.
29. Test the Trailer Harness function using a light board or multimeter.
30. Secure all harnesses using cable ties (not supplied).
31. Re-fit all removed parts and secure all fasteners, ensuring there are no squeaks or rattles.
32. Place the instructions in the glove box after fitment.