

TRAILBOSS

Towbar Fitting Instructions To Suit **FORD FOCUS 2013 ON** Part Number **FD134L** Rating **1500/150 kg**

PLACE THESE INSTRUCTIONS IN THE VEHICLE'S GLOVEBOX AFTER INSTALLATION IS COMPLETED

WARNING:

1. Do not, drill, cut, weld or otherwise modify the tow bar.
2. If you are using electric welding on a motor vehicle, **always** check that the vehicle is not equipped with electronic engine or instrument management equipment. Failure to do so could **destroy** any onboard computers. If in doubt, check with the vehicle's manufacturer.
3. The high tensile fasteners supplied with this product were used to achieve the specified rating. If replacement is required ensure that fasteners of the same rating & quality are used. Contact an authorised **Trailboss** dealer if further information is required.

General:

1. Ensure all hardware items have been included refer to assembly diagram.
2. It is recommended that the instructions are read through and completely understood before making any attempt to fit this product.
3. Be wary of any changes to vehicle designs or other accessories that may conflict with the installation of this product.
4. Before drilling ensure that the area is clear of fuel, electrical & other components.
5. All holes drilled into the body panels shall have all burrs & swarf removed then coated with a suitable rust preventative paint.
6. For vehicles that require the bumper to be cut. Ensure cut out area is in correct position on the vehicle prior to cutting the bumper.
7. The high tensile fasteners supplied with this product were used to achieve the specified rating. If replacement is required ensure that fasteners of the same rating & quality are used. Contact an authorized **Trailboss** dealer if further information is required.
8. Ensure that all hardware is fastened to torque list below check fasteners on regular basis.
9. Tow bar load rating sticker provided with this product shall be conspicuously located on inside rear end of the driver's door. **(See diagram below)**.
10. Trailboss recommends that you check your tow ball to ensure that it complies with the Australian standards **AS 4177.2**.
11. **PLEASE NOTE:** It is advised to remove your lug or tbm when not actually towing so as to produce a clear view of the vehicles registration plate if obscured, and to also provide maximum available departure angle
12. Pull Pin must be fit in down position.

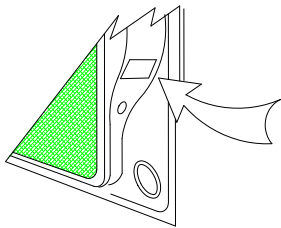

Place load rating sticker
inside driver's door here

FOR TRAILER TOWING PURPOSES ONLY
For towing capacity details please refer to vehicle owner's manual or to the manufacturer. Overloading can void your warranties.

RECOMMENDED ASSEMBLY TORQUE LISTING

Diameter	Grade 8.8 Bolt
M6	9.5 Nm
M8	21.7 Nm
M10	43.4 Nm
M12	77.3Nm
M14	146 Nm
M16	189.8 Nm

Tow bar Maintenance and Care.

Trailboss recommends that bolt torque's, as listed below, are routinely and regularly inspected and checked for correct tension. Replace any worn or defective parts.

We recommended to remove Tow Ball Mounts (TBM's, tongues or lugs) when not being used for any considerable length of time.

So as to avoid injury, when not towing it is suggested that the tongue, Pull Pin and R-clip are removed then stored in a safe, clean and dry place, away from excessive moisture.

Hitch Pull Pins and spring "R" clips are regularly checked for proper installation. Replace any worn or defective parts.



Towbar Fitting Instructions
 To Suit **FORD FOCUS 2013 ON**
 Part Number **FD134L**
 Rating **1500/150 kg**

PLACE THESE INSTRUCTIONS IN THE VEHICLE'S GLOVEBOX AFTER INSTALLATION IS COMPLETED

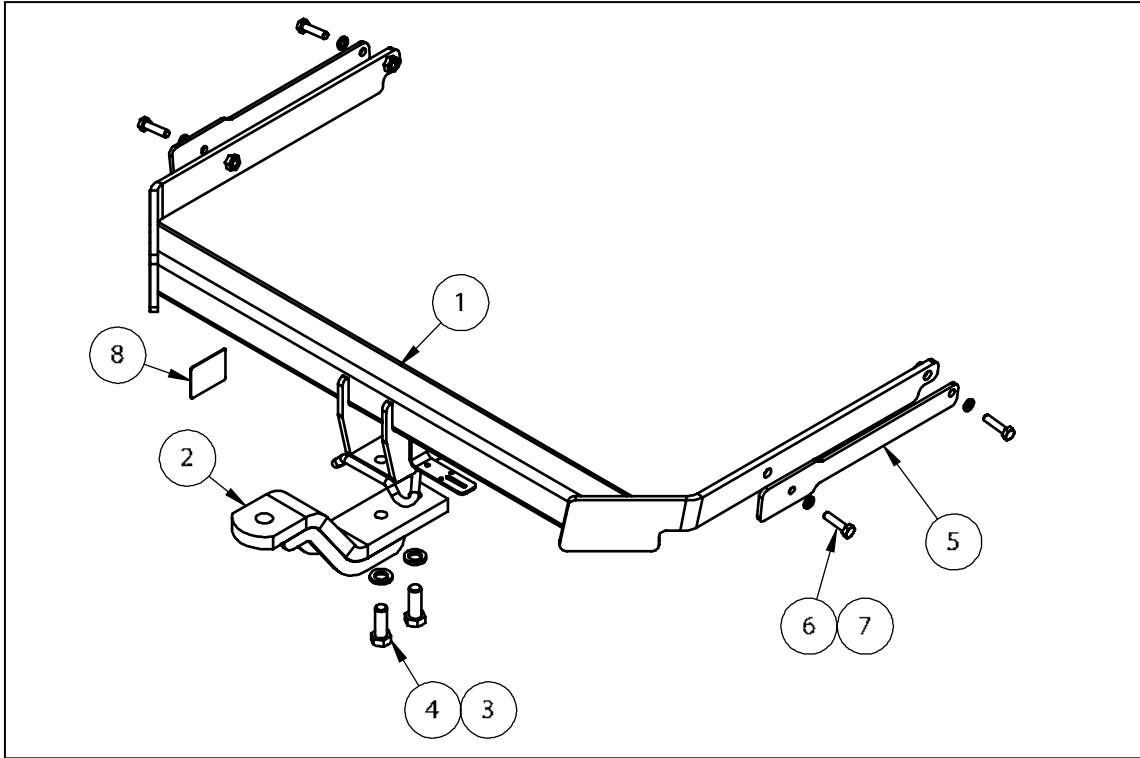

QTY	DESCRIPTION	ITEM NO
1	WELDED ASSEMBLY	1
1	LUG ASSEMBLY	2
2	M16x5x3.5 SPRING WASHER	3
2	M16x45 2.0P BOLT	4
2	LOOSE PLATE	5
4	BOLT M10-1.5x40mm	6
4	M10x3.5x2.2 SPRING WASHER	7
1	ACRYLIC COMPLIANCE PLATE	8

ADDITIONAL ITEMS



WIRING LOOM



FITTING INSTRUCTION



LR LABEL



Towbar Fitting Instructions
To Suit **FORD FOCUS 2013 ON**
Part Number **FD134L**
Rating **1500/150 kg**

PLACE THESE INSTRUCTIONS IN THE VEHICLE'S GLOVEBOX AFTER INSTALLATION IS COMPLETED

INSTRUCTION:

1. Remove Mud Flap from inside rear wheel well by removing 3x Screws. Repeat for opposite side of vehicle.
2. Move Wheel well cover to side to reveal Screw securing Bumper to the vehicle. Remove Screw and repeat for opposite side of vehicle

Remove 2 scrivenets from bottom of Bumper, connecting the Bumper to Bumper tabs.
3. Remove Screw beneath Taillight on side of vehicle. Repeat for opposite side of vehicle.

Accessing from underneath vehicle; remove 6x Nuts securing crash barrier and Bumper to vehicle.

Carefully remove Bumper from vehicle and store in safe place, Ensure rear parking sensors are disconnected.
4. Offer Towbar to vehicle, ensuring Sidearms are mounted inside the Chassis Inserts.

Mount Loose Plates to outside of Chassis Rails and secure with Bolts.
5. If vehicle is 5 Door variant, use appropriate tooling to make a Bumper cut 55mm long, measured from the Lower Lip, and 120mm wide.

A small Bumper Cut can be made on the Sedan variant if required.
6. Secure all Bolts to recommended torques and reassemble Bumper following steps 1 to 3 in reverse.



Wiring Loom Fitting Instructions
To Suit Ford Focus MY13
Part Number 100926-WL

Wiring Loom Installation Instructions

Ford Focus MY13
Part No: 100926-WL

Tail Harness Length Required: 400mm
ECU: 04826

Wiring Loom Installation Time: Approx 20 Mins



Wiring Loom Fitting Instructions
To Suit Ford Focus MY13
Part Number 100926-WL

1. In the luggage compartment, remove the parcel shelf and the floor carpet cover.
2. On the LHS of the luggage compartment, remove both access panels.
3. Locate and remove the two plastic fasteners securing the tail light in place.
4. From the outside of the vehicle, carefully dislodge the LHS tail light and disconnect the tail light assembly connectors.

Repeat steps 2 - 4 for the RHS.

5. Feed the previously disconnected vehicle tail light harness through the sheet metal cavity and into the vehicle luggage compartment.
6. Feed the trailer patch into the vehicle sheet metal cavity and into the luggage compartment.

Note: Ensure the trailer patch grommet is seated securely into the existing vehicle grommet hole.

7. Connect the trailer patch 6-way male connector to the tail light assembly connector.
8. Inside the luggage compartment access panel, apply double sided tape to the ECU (04826) and secure it to the vehicle sheet metal in a suitable location.
9. Connect the trailer patch 12-way connector to the ECU.
10. Route the 1-way trailer patch power harness (1) towards the bottom of the LHS luggage compartment.
11. Inside the fuse panel, locate the fuse slot 'F22'.
12. Insert the supplied 20-amp fuse (2) into the upper slot of the add-a-fuse (3).
13. Plug the add-a-fuse (3) into the 'F22' slot.
14. Connect the trailer patch power harness 1-way connector (4) to the add-a-fuse harness mating connector (5).

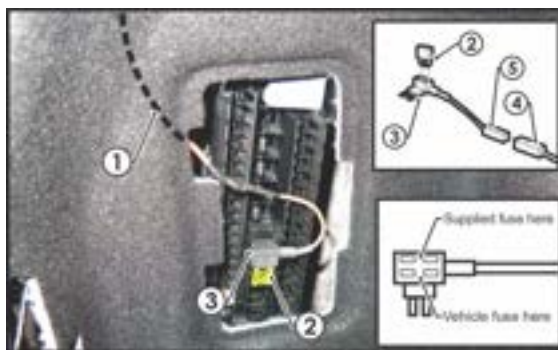



Wiring Loom Fitting Instructions
To Suit Ford Focus MY13
Part Number 100926-WL

15. On the LHS of the luggage compartment, connect the trailer patch 6-way female connector to the vehicle's mating connector.
16. Route the trailer patch along the outside of the vehicle towards the RHS tail light.
17. On the RHS tail light, connect the trailer patch 6-way male connectors to the 6-way female tail light connectors.
18. Mount the trailer socket to the tow bar mounting bracket using M4 fasteners (not supplied).
19. Route the tail harness (tail length 400mm) towards the trailer patch 8-way connector.
20. Waterproof the trailer patch 8-way connector and the tail harness 8-way male connector using silicone or grease.
21. Connect the trailer patch 8-way connector to the tail harness mating connector.
22. Test the trailer patch function using a light board or multimeter.
23. Secure all harnesses using cable ties (not supplied).
24. Re-fit all removed parts and secure all fasteners, ensuring there are no squeaks or rattles.
25. Place the instructions in the glove box compartment after fitment.