

TRAILBOSS

Towbar Fitting Instructions To Suit FORD MONDEO HATCH/WAGON Part Number FD206L Rating 1600/160 kg

PLACE THESE INSTRUCTIONS IN THE VEHICLE'S GLOVEBOX AFTER INSTALLATION IS COMPLETED

WARNING:

1. Do not, drill, cut, weld or otherwise modify the tow bar.
2. If you are using electric welding on a motor vehicle, **always** check that the vehicle is not equipped with electronic engine or instrument management equipment. Failure to do so could **destroy** any onboard computers. If in doubt, check with the vehicle's manufacturer.
3. The high tensile fasteners supplied with this product were used to achieve the specified rating. If replacement is required ensure that fasteners of the same rating & quality are used. Contact an authorised **Trailboss** dealer if further information is required.
4. If TBM is used in inverted position tow ball may make contact with rear tailgate when lowered, which could cause damage.

General:

1. Ensure all hardware items have been included refer to assembly diagram.
2. It is recommended that the instructions are read through and completely understood before making any attempt to fit this product.
3. Be wary of any changes to vehicle designs or other accessories that may conflict with the installation of this product.
4. Before drilling ensure that the area is clear of fuel, electrical & other components.
5. All holes drilled into the body panels shall have all burrs & swarf removed then coated with a suitable rust preventative paint.
6. For vehicles that require the bumper to be cut. Ensure cut out area is in correct position on the vehicle prior to cutting the bumper.
7. The high tensile fasteners supplied with this product were used to achieve the specified rating. If replacement is required ensure that fasteners of the same rating & quality are used. Contact an authorized **Trailboss** dealer if further information is required.
8. Ensure that all hardware is fastened to torque list below check fasteners on regular basis.
9. Tow bar load rating sticker provided with this product shall be conspicuously located on inside rear end of the driver's door. **(See diagram below).**
10. Trailboss recommends that you check your tow ball to ensure that it complies with the Australian standards **AS 4177.2.**
11. **PLEASE NOTE:** It is advised to remove your lug or tbn when not actually towing so as to produce a clear view of the vehicles registration plate if obscured, and to also provide maximum available departure angle
12. Pull Pin must be fit in down position.

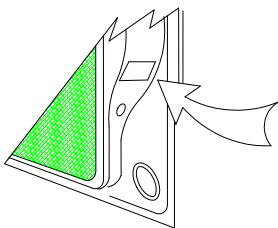

Place load rating sticker
inside driver's door here

FOR TRAILER TOWING PURPOSES ONLY
For towing capacity details please refer to vehicle owner's manual or to the manufacturer. Overloading can void your warranties.

RECOMMENDED ASSEMBLY TORQUE LISTING

<u>Diameter</u>	<u>Grade 8.8 Bolt</u>
M6	9.5 Nm
M8	21.7 Nm
M10	58.0 Nm
M12	77.3Nm
M14	146 Nm
M16	189.8 Nm

Tow bar Maintenance and Care.

Trailboss recommends that bolt torque's, as listed below, are routinely and regularly inspected and checked for correct tension. Replace any worn or defective parts.

We recommended to remove Tow Ball Mounts (TBM's, tongues or lugs) when not being used for any considerable length of time.

So as to avoid injury, when not towing it is suggested that the tongue, Pull Pin and R-clip are removed then stored in a safe, clean and dry place, away from excessive moisture.

Hitch Pull Pins and spring "R" clips are regularly checked for proper installation. Replace any worn or defective parts.

TRAILBOSS

Towbar Fitting Instructions To Suit FORD MONDEO HATCH/WAGON Part Number FD206L Rating 1600/160 kg

PLACE THESE INSTRUCTIONS IN THE VEHICLE'S GLOVEBOX AFTER INSTALLATION IS COMPLETED

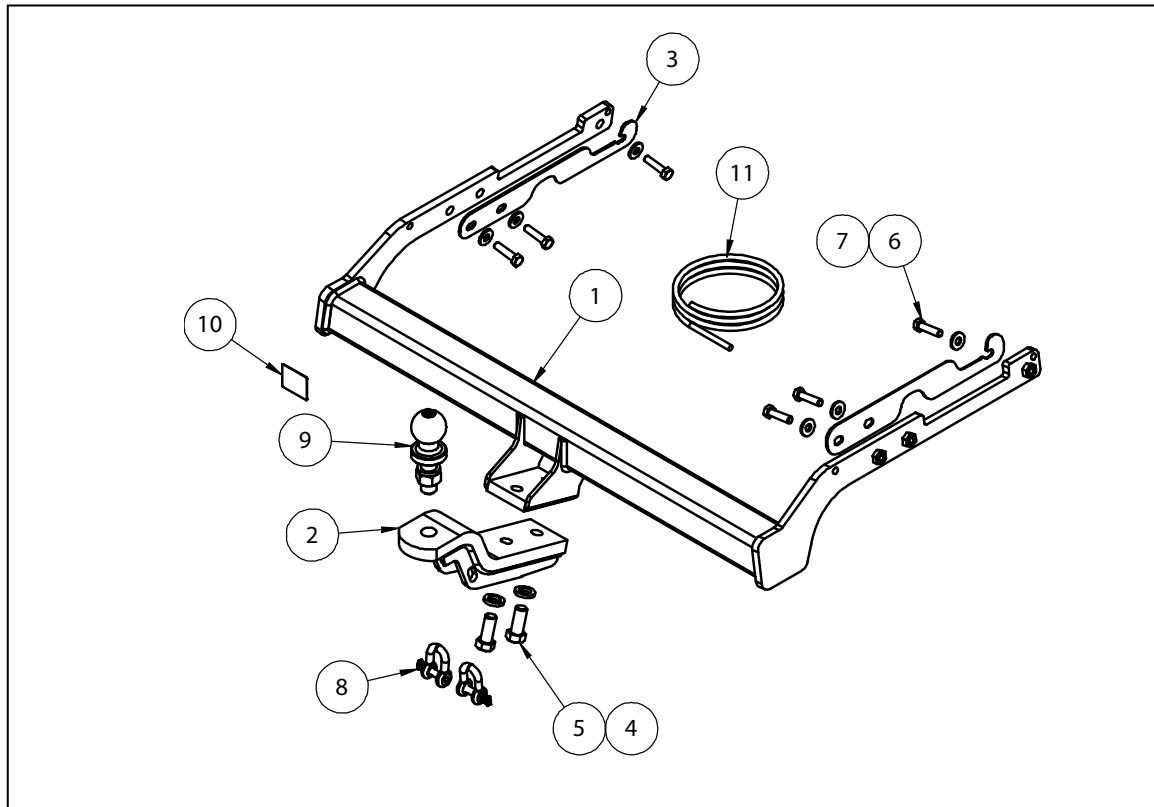

QTY.	DESCRIPTION	ITEM NO.
1	WELDED CENTRE SECTION	1
1	TONGUE ASSEMBLY	2
2	WASHER PLATE	3
2	SPRING WASHER M16x5x3.5	4
2	SET SCREW M16-2.00x40 Z/P	5
6	BOLT M10-1.5x40mm	6
6	WASHER FLAT M10x25.4x3	7
2	10mm "D" SHACKLE	8
1	50mm TOWBALL	9
1	ACRYLIC COMPLIANCE LABEL	10
1	16 STRANDx0.3mm 7 CORE CABLE	11



Towbar Fitting Instructions
To Suit FORD MONDEO HATCH/WAGON
Part Number FD206L
Rating 1600/160 kg

PLACE THESE INSTRUCTIONS IN THE VEHICLE'S GLOVEBOX AFTER INSTALLATION IS COMPLETED

INSTRUCTION:

1. Open the rear tailgate.
2. Remove 2 screws from the RHS taillight, located on the outside for the wagon, and inside the boot for the hatch.
Dislodge the taillight & disconnect the wiring.
Repeat for LHS.
3. Remove 1 screw on the RHS of the bumper for the wagon.
Repeat for LHS
4. Remove 2 scrivenets located in the RHS taillight bumper cavity.
Repeat for LHS.
5. Remove 4 screws in the RHS wheel arch.
Repeat for LHS.
6. Remove 6 screws and 1 scrivenet located on the underside of the RHS bumper.
Repeat for LHS.
7. Remove 4 flange nuts from the underside of the rear diffuser.
Set aside the rear diffuser.
8. Unclip the bumper and set aside.
9. Remove 4 bolts from the RHS of the intrusion beam and 3 bolts from LHS of the intrusion beam.
Discard the impact beam and bolts.
10. Offer the main towbar assembly to the vehicle.
11. Place the supplied washer plate on the outside of the chassis rail.
Mount 3 bolts through the chassis rail per side.
Torque bolts to the following specification:
 - M10 Bolts to 58Nm
12. Make a bumper cut as per the last page.





Wiring Loom Fitting Instructions
To Suit Ford Mondeo MD Wagon / Hatch
Part Number 101243-WL

Wiring Loom Installation Instructions

Ford Mondeo MD Wagon / Hatch
Part No: 101243-WL

ECU Required: 04828
Tail Harness Length Required: 1200mm

Wiring Loom Installation Time: Approx 40 Mins (Wagon)
Wiring Loom Installation Time: Approx 30 Mins (Hatch)

 Important	Due to possible vehicle variations, always confirm any noted vehicle colour wires with a multi-meter to ensure the correct function is identified before soldering or scotch locking. For vehicle wires denoted with two colours (example; RED/GREEN) the first colour will always be the main wire colour while the second colour is the thinner trace colour on the wire.
 Important	It is not possible to over-ride the Factory RPA. It can however, be disabled through a switch on the vehicle dash.



Wiring Loom Fitting Instructions To Suit Ford Mondeo MD Wagon / Hatch Part Number 101243-WL

All steps apply to both Wagon and Hatch unless otherwise specified.

1. On the rear of the vehicle, remove cargo holder and the floor carpet cover.
2. Remove the parcel shelf, luggage compartment tool trays and spare wheel cover.
3. Fold down rear seats.

This step for Wagon only:

4. Loosen rail mounting bolts.
5. Remove the luggage compartment rear trim by first removing the clips and then pulling the trim in an upwards direction.
6. Remove LHS luggage compartment upper panel trim.
7. Dislodge LHS compartment lower trim.

Step 8 for Wagon models only:

8. At the LHS exterior rear quarter of the vehicle below the air vent, remove the vehicle grommet and drill the grommet hole out to Ø30mm. Ensure the interior area is clear of obstructions before drilling.

Note: If the vehicle grommet is occupied, drill into the sheet metal next to the grommet.
Apply rust inhibitor after drilling.

Step 9 for Hatch models only:

9. At the LHS exterior rear quarter of the vehicle above the air vent, drill out a hole in the vehicle sheet metal to Ø30mm. **Ensure the interior area is clear of obstructions before drilling.**
Apply rust inhibitor after drilling.
10. Route the trailer patch (P/No:101243-WL) through the previously drilled hole.
11. Ensure the trailer patch grommet is seated correctly and makes a good seal. Secure the grommet with a cable tie (not supplied).
12. Remove sound deadening material (1) to gain access to vehicle cavity.
13. Using alcohol wipe clean the LHS outer surface of the inner sheet metal skin (2) and the underside of the ECU (04828).
14. Apply double sided tape to the ECU (04828) (3) and secure it to the vehicle sheet metal inside the cavity in the area shown.
15. Connect the trailer patch 12-way connector (4) to the ECU (04828). **Ensure ECU connector is facing downwards.**
16. Secure the trailer patch ring terminal (5) to the vehicle grounding point.

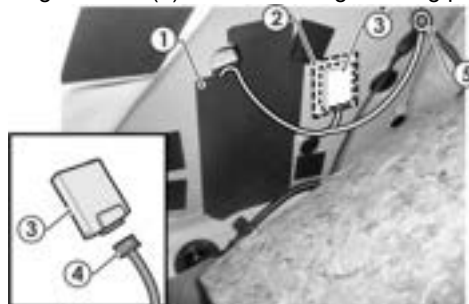



Wiring Loom Fitting Instructions
To Suit Ford Mondeo MD Wagon / Hatch
Part Number 101243-WL

17. Disconnect the LHS tail light connectors and patch the trailer patch connectors in between.
18. Route the trailer patch across the rear exterior of the vehicle towards the RHS of the vehicle. Avoid hot areas and sharp objects.
19. Locate the LHS rear quarter grey connector on the floor from the LHS wheel arch. Disengage the secondary lock and then fit terminal to the male connector. **Note: If no mating connector is present cut off the terminal on the harness and solder directly to the BROWN/RED wire. Note: Test the vehicle wires first to confirm the functions.**

Function	Trailer Patch	Vehicle Harness
12V+	ORANGE	BROWN/RED

This step for Wagon models only:

20. In the LHS of the luggage compartment, locate the main vehicle harness located above the vehicle grounding point. Following the table below, connect the ezy-tap to the vehicle harness BLACK/BLUE wire and then connect the trailer patch BLACK/WHITE wire terminal to the ezy-tap. **Note: Test the vehicle wires first to confirm the functions.**

Function	Trailer Patch	Vehicle Harness
REV	BLACK/WHITE	BLACK/BLUE

This step for Hatch models only:

21. On the LHS of the luggage compartment wheel arch, following the table below, connect the ezy-tap (1) to the vehicle harness BLACK/WHITE wire (2) and then connect the trailer patch BLUE/WHITE wire terminal (3) to the ezy-tap (1). **Note: Test the vehicle wires first to confirm the functions.**

Function	Trailer Patch	Vehicle Harness
REV	BLACK/WHITE	BLUE/WHITE

22. Mount the trailer socket to the towbar mounting bracket using M4 fasteners (not supplied).
23. Route the tail harness (tail length 1200mm) towards the LHS drilled out hole.
24. Connect the tail harness 8-way connector to the trailer patch 8-way mating connector.
25. Waterproof the trailer patch 8-way connector and the tail harness 8-way male connector using silicone or grease (not supplied).
26. Test the Trailer Harness function using a light board or multi-meter.
27. Secure all harnesses using cables ties (not supplied).
28. Re-fit all removed parts and secure all fasteners, ensuring there are no squeaks or rattles.
29. Place the instructions in the glove box after fitment.
30. To disable the factory RPA, turn off the RPA using the dash button.