

# TRAILBOSS

## Towbar Fitting Instructions To Suit **HOLDEN VF COMMODORE SEDAN 05/2013 - ON** Part Number **HD95L** Rating **1200/120 kg**

PLACE THESE INSTRUCTIONS IN THE VEHICLE'S GLOVEBOX AFTER INSTALLATION IS COMPLETED

### **WARNING:**

1. Do not, drill, cut, weld or otherwise modify the tow bar.
2. If you are using electric welding on a motor vehicle, **always** check that the vehicle is not equipped with electronic engine or instrument management equipment. Failure to do so could **destroy** any onboard computers. If in doubt, check with the vehicle's manufacturer.
3. The high tensile fasteners supplied with this product were used to achieve the specified rating. If replacement is required ensure that fasteners of the same rating & quality are used. Contact an authorised **Trailboss** dealer if further information is required.

### **General:**

1. Ensure all hardware items have been included refer to assembly diagram.
2. It is recommended that the instructions are read through and completely understood before making any attempt to fit this product.
3. Be wary of any changes to vehicle designs or other accessories that may conflict with the installation of this product.
4. Before drilling ensure that the area is clear of fuel, electrical & other components.
5. All holes drilled into the body panels shall have all burrs & swarf removed then coated with a suitable rust preventative paint.
6. For vehicles that require the bumper to be cut. Ensure cut out area is in correct position on the vehicle prior to cutting the bumper.
7. The high tensile fasteners supplied with this product were used to achieve the specified rating. If replacement is required ensure that fasteners of the same rating & quality are used. Contact an authorized **Trailboss** dealer if further information is required.
8. Ensure that all hardware is fastened to torque list below check fasteners on regular basis.
9. Tow bar load rating sticker provided with this product shall be conspicuously located on inside rear end of the driver's door. **(See diagram below).**
10. Trailboss recommends that you check your tow ball to ensure that it complies with the Australian standards **AS 4177.2.**
11. **PLEASE NOTE:** It is advised to remove your lug or tbm when not actually towing so as to produce a clear view of the vehicles registration plate if obscured, and to also provide maximum available departure angle
12. Pull Pin must be fit in down position.

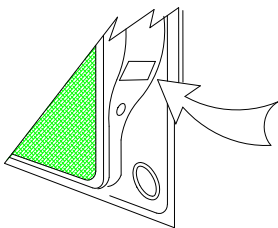

Place load rating sticker  
inside driver's door here

**FOR TRAILER TOWING PURPOSES ONLY**  
For towing capacity details please refer to vehicle owner's manual or to the manufacturer. Overloading can void your warranties.

#### **RECOMMENDED ASSEMBLY TORQUE LISTING**

<u>Diameter</u>	<u>Grade 8.8 Bolt</u>
M6	9.5 Nm
M8	21.7 Nm
M10	43.4 Nm
M12	77.3Nm
M14	146 Nm
M16	189.8 Nm

### **Tow bar Maintenance and Care.**

Trailboss recommends that bolt torque's, as listed below, are routinely and regularly inspected and checked for correct tension. Replace any worn or defective parts.

We recommended to remove Tow Ball Mounts (TBM's, tongues or lugs) when not being used for any considerable length of time.

So as to avoid injury, when not towing it is suggested that the tongue, Pull Pin and R-clip are removed then stored in a safe, clean and dry place, away from excessive moisture.

# TRAILBOSS

## Towbar Fitting Instructions

To Suit **HOLDEN VF COMMODORE SEDAN 05/2013 - ON**

Part Number **HD95L**

Rating **1200/120 kg**

PLACE THESE INSTRUCTIONS IN THE VEHICLE'S GLOVEBOX AFTER INSTALLATION IS COMPLETED

Hitch Pull Pins and spring "R" clips are regularly checked for proper installation. Replace any worn or defective parts.

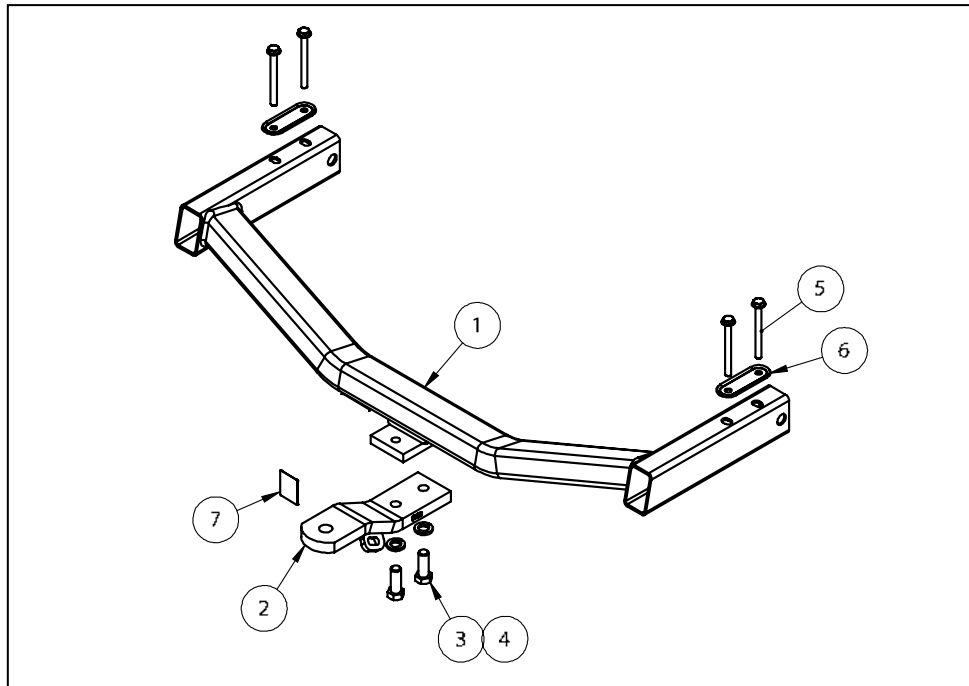

QTY	DESCRIPTION	ITEM NO
1	WELDED ASSEMBLY	1
1	ASSEMBLY LUG	2
2	M16x45x2.0P BOLT	3
2	M16x5x3.5 SPRING WASHER	4
4	M10x105x1.5P BOLT	5
2	FORMED BOOT PLATE	6
1	ACRYLIC COMPLIANCE PLATE	7

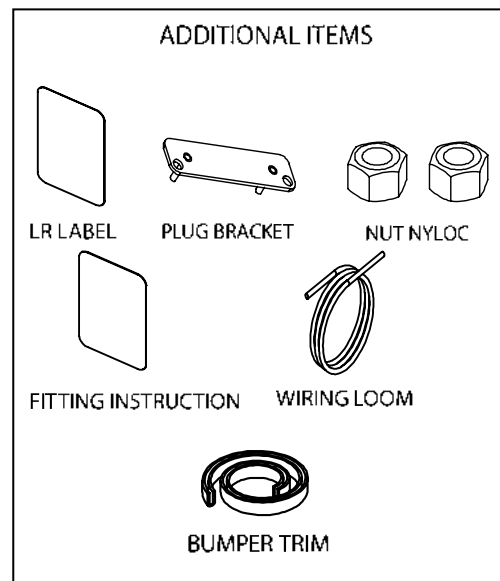



Towbar Fitting Instructions  
To Suit **HOLDEN VF COMMODORE SEDAN 05/2013 - ON**  
Part Number **HD95L**  
Rating **1200/120 kg**

PLACE THESE INSTRUCTIONS IN THE VEHICLE'S GLOVEBOX AFTER INSTALLATION IS COMPLETED

**INSTRUCTION:**

1. In the passenger side wheel well, remove 5x Screws connecting the rear bumper to the wheel well cover.  
Repeat for passenger side.
2. Remove 3x Scrivets from underneath the bumper tab, securing the bumper to the wheel well.
3. Ensure that sensor cables are unplugged, then carefully peel away bumper and place to the side in a safe area.
4. Remove polystyrene insert from rear of vehicle and dispose.
5. From inside the boot, remove 4x Screws (2 per side) that secure the rear inside plastic trim to the inside rear chassis.  
Remove the trim by lifting upwards and place to the side.
6. Lift spare tire cover to gain access underneath.  
Remove the silver tape covering the 2 bolt holes. Repeat for opposite side of vehicle.
7. Offer towbar to vehicle, inserting the towbar side arms into the existing chassis rail holes.  
Force may be required to slide inside chassis rail.
8. Fit loose plates and bolts inside cavity in newly exposed bolt holes.  
Repeat for opposite side of vehicle.  
Tighten all bolts to torques specified on page 1.
9. Cut rear bumper skin by following the Holden original factory bumper indent.  
Use a small pilot drill to pierce the skin to allow a small saw or similar device to cut.  
Clean any raw edges with a file.  
Refit the bumper following steps 1 to 6 in reverse.



Wiring Loom Fitting Instructions  
To Suit Holden Commodore VF  
Part Number 200000-WL

## Wiring Loom Installation Instructions

Holden Commodore VF

Part No: 200000-WL

ECU Required: 04837

Tail Harness Length Required: 1200mm

Wiring Loom Installation Time: Approx 30 Mins



Wiring Loom Fitting Instructions  
To Suit Holden Commodore VF  
Part Number 200000-WL

1. On the rear of the vehicle, remove the luggage compartment floor mat.
2. Remove the rear luggage compartment trim by removing the four fasteners.
3. Remove the LHS luggage compartment trim by removing the two fasteners. Repeat for RHS.
4. Remove the rear bumper from the vehicle.
5. Pierce a hole into the LHS vehicle grommet and route the trailer patch harness YELLOW/BLACK and RED/BLACK wires into the vehicle grommet.
6. Connect the vehicle 1-way connector to the power harness 1-way connector.
7. Route the power harness ring terminal through the vehicle grommet, towards the battery. Tie excess length of power harness.
8. At the LHS tail light area, solder the trailer patch harness wires to the tail light connector wires by following the diagram below:

Function	Trailer Patch	Vehicle Connector
L.IND	YELLOW / BLACK	BLUE / WHITE
BRAKE / TAIL	RED / BLACK	GREY / YELLOW

**Note: Ensure to secure each individual solder with tape.**

**Note: Do not connect the power harness ring terminal to the battery at this stage.**

9. Route the trailer patch towards the RHS of the vehicle.
10. At the RHS tail light area, solder the trailer patch harness GREEN/BLACK wire to the tail light connector wire and route the trailer patch harness BLACK/WHITE reverse wire above the RHS wheel arch area and solder to the vehicle harness by following the diagram below:

Function	Trailer Patch	Vehicle Connector
REVERSE	BLACK / WHITE	GREEN / WHITE
R.IND	GREEN / BLACK	BLUE / PURPLE

**Note: Ensure to secure each individual solder with tape.**



Wiring Loom Fitting Instructions  
To Suit Holden Commodore VF  
Part Number 200000-WL

11. Secure the trailer patch ground ring terminal (1) to the vehicle sheet metal area using a Tek Screw (2) (not supplied). Connect the trailer patch harness ECU connector (3) to the ECU (P/No: 04837) (4).
  
12. Mount the ECU on to the towbar interior face and secure with cable ties (not supplied).
13. Mount the trailer socket to the tow bar mounting bracket using M4 fasteners (not supplied).
14. Route the tail harness (tail length 1200mm) towards the trailer patch tail connector.
15. Connect the tail harness 8-way connector to the trailer patch 8-way mating connector.
16. Waterproof the trailer patch 8-way connector and the tail harness 8-way male connector using silicone or grease.
17. Connect the power harness positive terminal to the battery.
18. Test the trailer wiring harness function using a light board or multimeter.
19. Secure all harnesses using cable ties (not supplied).
20. Re-fit all removed parts and secure all fasteners, ensuring there are no squeaks or rattles.
21. Place the fitting instructions in the glove box after fitment.