



Towbar Fitting Instructions
To Suit HONDA ACCORD EXI SEDAN 9/89-9/93
Part Number HN36A
Rating 600Kg

1. Ensure all hardware items have been included.
2. Remove bumper bar assembly.
3. Remove bumper support frame.
3. Mark, cut and drill as per diagrams.
NOTE: Care must be taken during this procedure to maintain correct bumper alignment.
4. Fit new support brackets supplied but do not tighten bolts.
5. Refit bumper support frame.
6. Trim off tab from middle bottom edge of bumper bar (see sketch).
7. Bend original centre bumper mounting plate (on car) upwards.
8. Hold towbar in position matching existing holes in back of car.
9. Ensure towbar is square with vehicle.
10. Screw self tappers into centre holes to hold towbar in position.
11. Refit bumper assembly.
12. Move bumper in or out until aligned correctly.
13. Tighten new bumper support bracket bolts with long socket extension from under car.
14. Using hole in tail as guide drill up into boot.
15. Fit loose plate, coach bolt, washer and nut.
16. Using small tab (welded to dropper on towbar) with 6mm hole as guide, drill up through the bottom and fit 6mm bolt supplied.
17. Tighten all bolts to torque listing below.

RECOMMENDED ASSEMBLY TORQUE LISTING

<u>Diameter</u>	<u>Grade 8.8 Bolt</u>
	Nm
M6	9.5
M8	21.7
M10	43.4
M12	77.3
M14	121.0
M16	189.8

TRAILBOSS

Towbar Fitting Instructions
To Suit HONDA ACCORD EXI SEDAN 9/89-9/93
Part Number HN36A
Rating 600Kg

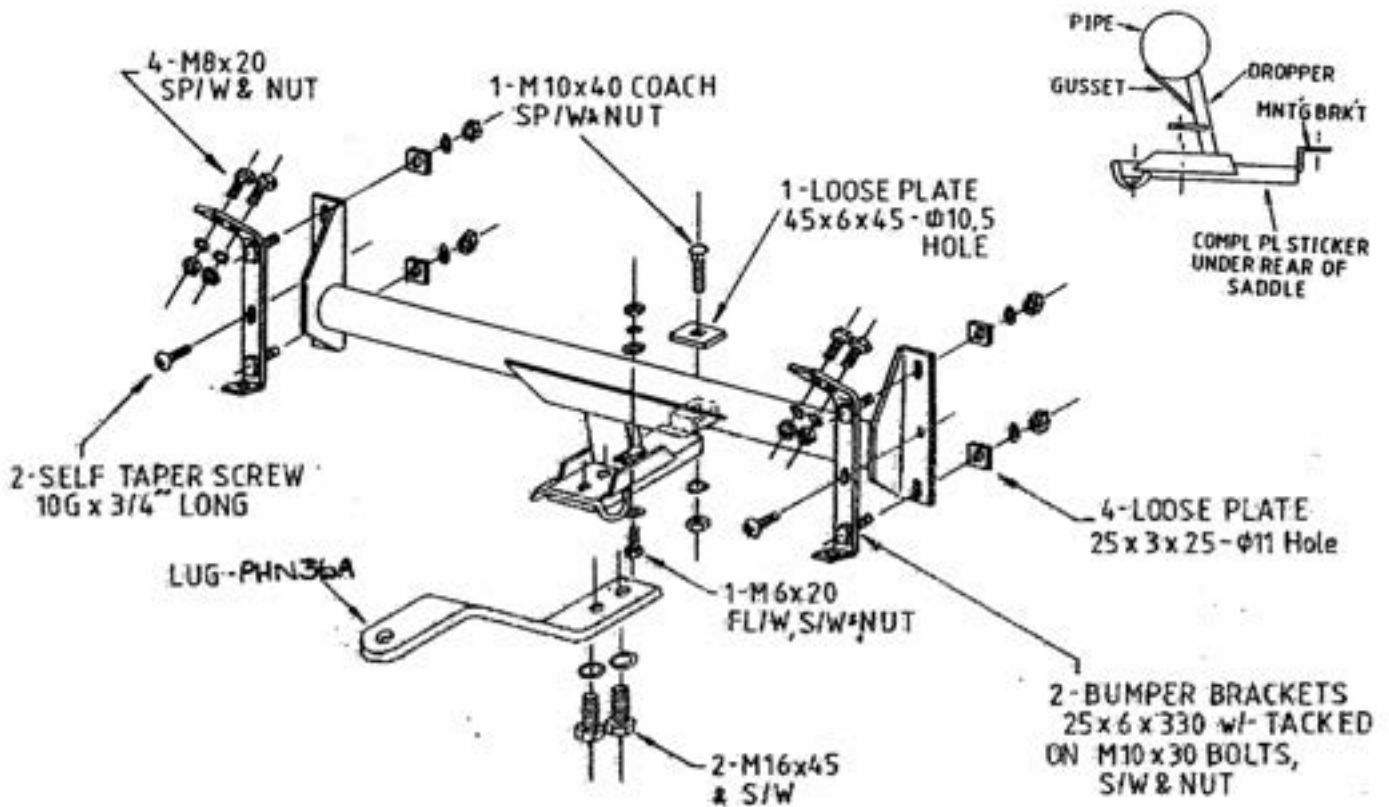

TRAILBOSS

Towbar Fitting Instructions
To Suit HONDA ACCORD EXI SEDAN 9/89-9/93
Part Number HN36A
Rating 600Kg

