



Towbar Fitting Instructions  
To Suit HONDA HRV 3 DR` & 5 DR` 1/99-ON  
Part Number HN47  
Rating 1200Kg

1. Ensure all hardware items have been included.
2. Remove lower bumper skirt.
3. Remove bumper.
4. Fit two tapped plates on wire one each side through large vertical holes into small vertical holes of sub frame.
5. Fit towbar up to vehicle so as tabs on side arms align with tapped plates fitted. Fit bolts and spring washers semi tight.
6. Using marking pen, mark all remaining bolting holes. **NOTE: Make sure towbar is square to vehicle.**
7. Remove towbar.
8. Centre pop all marked spots and drill out to 11mm.
9. Refit towbar using bolts on wire and tapped plates through nearest large hole and tighten to torque listing.
10. Cut lower bumper skirt as per sketch.
11. Refit bumper and lower skirt.

**RECOMMENDED ASSEMBLY TORQUE LISTING**

<u>Diameter</u>	<u>Grade 8.8 Bolt</u>
	<b>Nm</b>
M6	9.5
M8	21.7
M10	43.4
M12	77.3
M14	121.0
M16	189.8

Towbar Fitting Instructions  
To Suit HONDA HRV 3 DR` & 5 DR` 1/99-ON  
Part Number HN47  
Rating 1200Kg

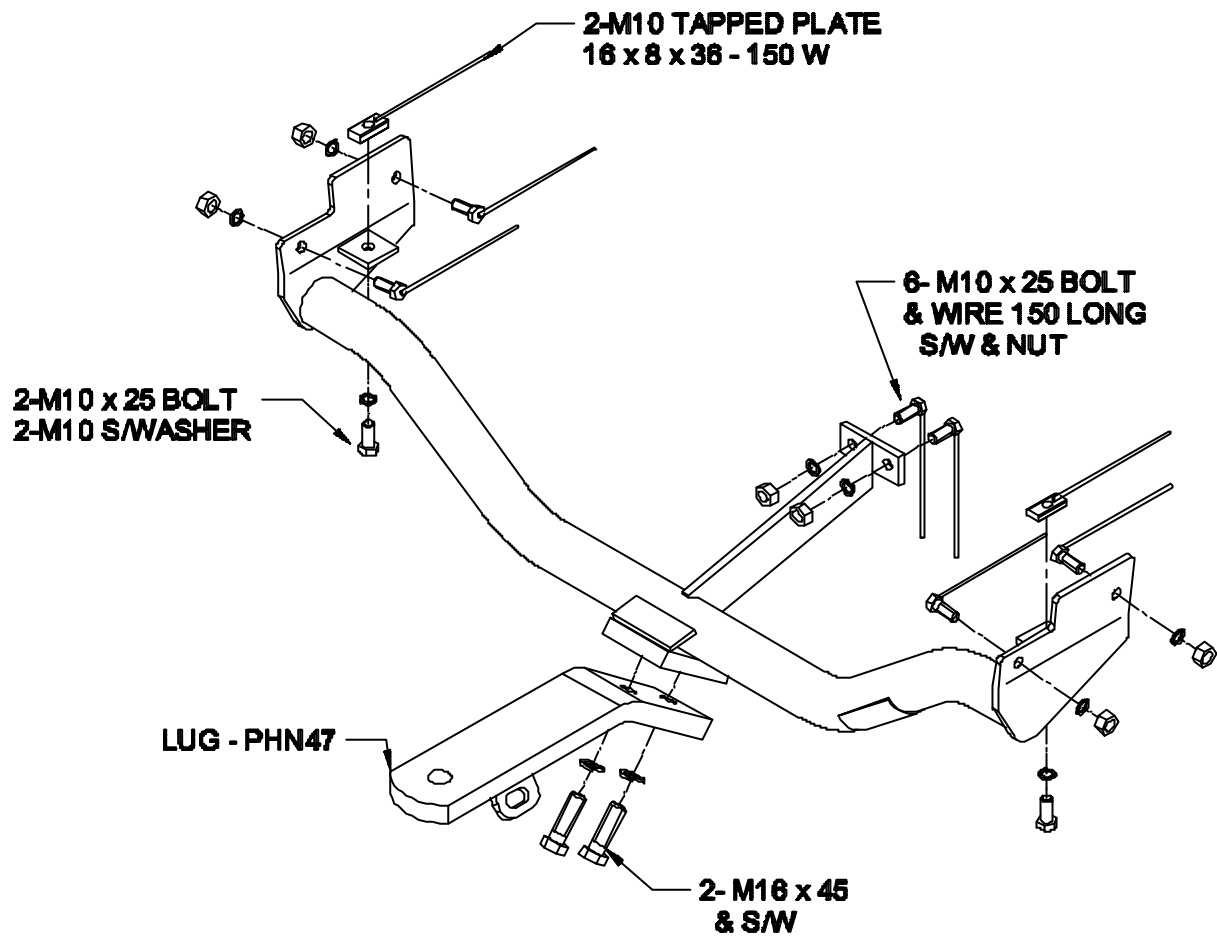

Towbar Fitting Instructions  
To Suit HONDA HRV 3 DR` & 5 DR` 1/99-ON  
Part Number HN47  
Rating 1200Kg

