

# TRAILBOSS

Towbar Fitting Instructions  
To Suit **HY30L**  
Part Number **HYUNDAI I30 2012**  
Rating **1300/75 kg**

PLACE THESE INSTRUCTIONS IN THE VEHICLE'S GLOVEBOX AFTER INSTALLATION IS COMPLETE

## WARNING:

1. Do not, drill, cut, weld or otherwise modify the tow bar.
2. If you are using electric welding on a motor vehicle, **always** check that the vehicle is not equipped with electronic engine or instrument management equipment. Failure to do so could **destroy** any onboard computers. If in doubt, check with the vehicle's manufacturer.
3. The high tensile fasteners supplied with this product were used to achieve the specified rating. If replacement is required ensure that fasteners of the same rating & quality are used. Contact an authorised **Trailboss** dealer if further information is required.

## General:

1. Ensure all hardware items have been included refer to assembly diagram.
2. It is recommended that the instructions are read through and completely understood before making any attempt to fit this product.
3. Be wary of any changes to vehicle designs or other accessories that may conflict with the installation of this product.
4. Before drilling ensure that the area is clear of fuel, electrical & other components.
5. All holes drilled into the body panels shall have all burrs & swarf removed then coated with a suitable rust preventative paint.
6. For vehicles that require the bumper to be cut. Ensure cut out area is in correct position on the vehicle prior to cutting the bumper.
7. The high tensile fasteners supplied with this product were used to achieve the specified rating. If replacement is required ensure that fasteners of the same rating & quality are used. Contact an authorized **Trailboss** dealer if further information is required.
8. Ensure that all hardware is fastened to torque list below check fasteners on regular basis.
9. Tow bar load rating sticker provided with this product shall be conspicuously located on inside rear end of the driver's door. **(See diagram below)**.
10. Trailboss recommends that you check your tow ball to ensure that it complies with the Australian standards **AS 4177.2**.
11. **PLEASE NOTE:** It is advised to remove your lug or tbn when not actually towing so as to produce a clear view of the vehicles registration plate if obscured, and to also provide maximum available departure angle
12. Pull Pin must be fit in down position.

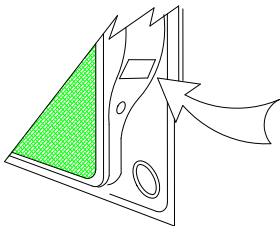

Place load rating sticker  
inside driver's door here

**FOR TRAILER TOWING PURPOSES ONLY**  
For towing capacity details please refer to vehicle owner's manual or to the manufacturer. Overloading can void your warranties.

### RECOMMENDED ASSEMBLY TORQUE LISTING

Diameter	Grade 8.8 Bolt
M6	9.5 Nm
M8	21.7 Nm
M10	43.4 Nm
M12	77.3Nm
M14	146 Nm
M16	189.8 Nm

## Tow bar Maintenance and Care.

Trailboss recommends that bolt torque's, as listed below, are routinely and regularly inspected and checked for correct tension. Replace any worn or defective parts.

We recommended to remove Tow Ball Mounts (TBM's, tongues or lugs) when not being used for any considerable length of time.

So as to avoid injury, when not towing it is suggested that the tongue, Pull Pin and R-clip are removed then stored in a safe, clean and dry place, away from excessive moisture.

Hitch Pull Pins and spring "R" clips are regularly checked for proper installation. Replace any worn or defective parts.

# TRAILBOSS

Towbar Fitting Instructions  
 To Suit **HY30L**  
 Part Number **HYUNDAI I30 2012**  
 Rating **1300/75 kg**

PLACE THESE INSTRUCTIONS IN THE VEHICLE'S GLOVEBOX AFTER INSTALLATION IS COMPLETE

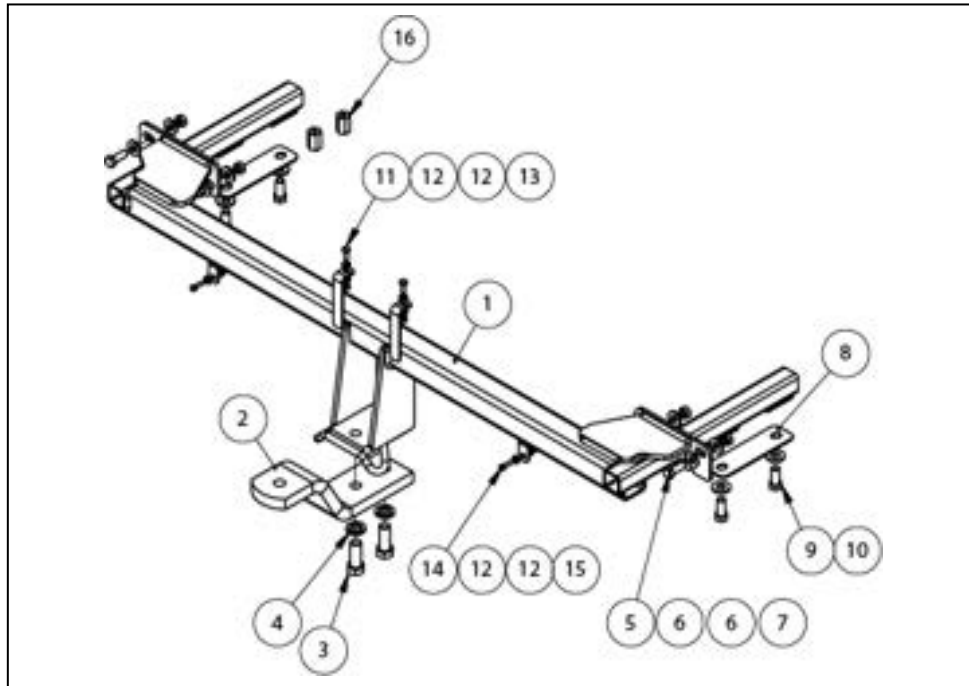

QTY	DESCRIPTION	ITEM NO
1	WELDED ASSEMBLY	1
1	LUG	2
2	M16x45 2.0P BOLT	3
2	M16x5x3.5 SPRING WASHER	4
4	SET SCREW HEX HD M10x30x1.5P	5
8	WASHR FT M10x25.4x3	6
4	HEX NUT M10x1.5	7
2	WASHER PLATE	8
4	M12x30 BOLT 1.75P	9
4	WASHER M12x28.8x3	10
2	SET SCREW M6x16	11
8	WASHER FLAT M6x12.5x1.2	12
2	NYLOC NUT M6-1.00 Z/P	13
2	SET SCREW HEX HD M5x20x0.8P	14
2	NUT NYLOC M5-0.8 Z/P	15
2	30mm M8x1.25P HEX SPACER	16

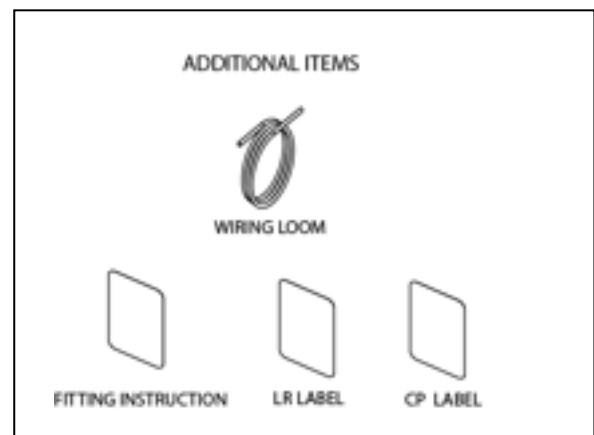



Towbar Fitting Instructions  
To Suit **HY30L**  
Part Number **HYUNDAI I30 2012**  
Rating **1300/75 kg**

PLACE THESE INSTRUCTIONS IN THE VEHICLE'S GLOVEBOX AFTER INSTALLATION IS COMPLETE

**INSTRUCTION:**

1. Open Tailgate and release 2 Screws from the LHS Tail Light. Repeat RHS.
2. Dislodge the Tail Lights and pull Grommet out of back panel to expose Connector. Remove and place in safe place.
3. Release 1 Screw and 1 Scrivet from inside each Tail Light cavity.
4. Release the 3 Screws from the RHS Wheel Arch. Release the 2 Screws from the bottom of the rear Fascia. Repeat for LHS.
5. Remove the Exhaust by removing the Nuts from the Exhaust Flange joint and removing 2 Rubber Hangers.
6. Disconnect the exhaust Shield by removing 5 Nuts.
7. Remove the 4 Nuts from behind the vehicle rear panel.
8. Carefully dislodge the rear Bumper. If fitted, remove the rear Parking Assist Sensors and Wiring Harness. Place in a safe place.
9. Remove the 5 Scrivets from the Impact Beam, and retain only two. Remove and retain 2 Plastic Bumper Brackets to be mounted onto Towbar. If fitted, remove Smart Key Antenna from Impact Beam. Discard impact beam.
10. If fitted, temporarily dislodge Carbon Canister underneath Chassis Rail by loosening two M8 Nuts (LHS). Remove Rubber Grommet from underneath chassis rail. Enlarge most rear hole to 14 mm. Repeat for both sides.
11. Offer Towbar to vehicle and insert Side Arms into Chassis Rail opening. Loosely fasten to back panel using M10 Nuts, Washers, and Bolts. Loosely fasten Towbar underneath Chassis Rails using Washer Plate, M12 Bolts and Washers. Refer to page 2 for fastener sequence. Tighten all fasteners to torque listed on page 1.
12. For vehicles fitted with Carbon Canister, attach 30mm Hex Spacers onto Studs in LHS Chassis Rail and re-assemble Carbon Canister using M8 Bolts and Washers. Tighten to 25Nm.
13. Attach Plastic Bumper Brackets onto the Towbar using M5 Bolts, Nuts and Washers. Tighten to 8Nm.
14. If fitted, attach Smart Key Antenna to the Sensor Holder on Towbar using M5 Bolts, Washers and Nuts.
15. Cut out Exhaust Heat Shield and Cut Bumper as shown.
16. Reassemble Bumper, Heat Shield Exhaust, and Tail Lights in reverse order.



Towbar Fitting Instructions  
To Suit **HY30L**  
Part Number **HYUNDAI I30 2012**  
Rating **1300/75 kg**

PLACE THESE INSTRUCTIONS IN THE VEHICLE'S GLOVEBOX AFTER INSTALLATION IS COMPLETE

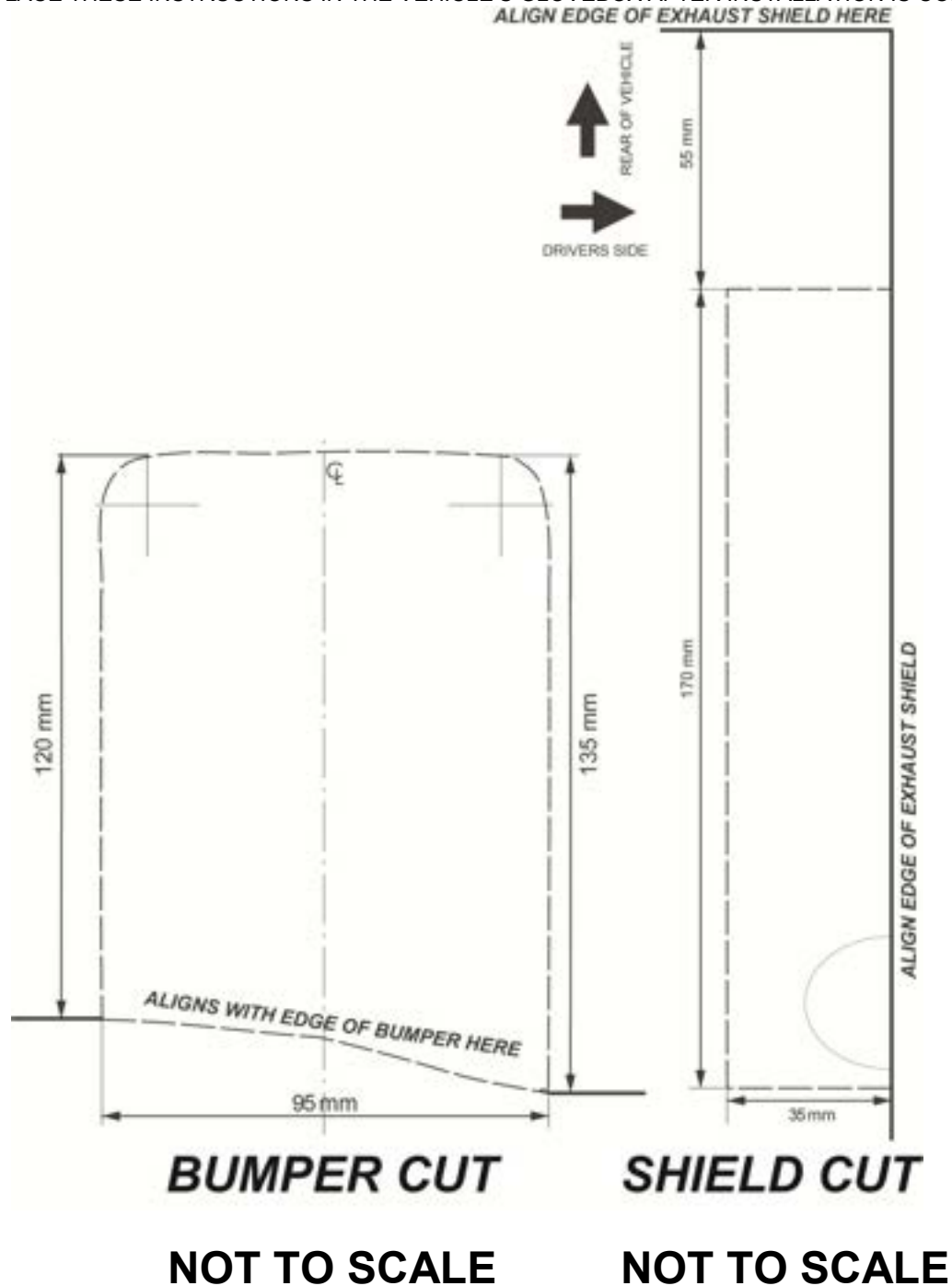



Wiring Loom Fitting Instructions  
To Suit Hyundai i30 Hatch MY12  
Part Number 100841-WL

Wiring Loom Installation Instructions

Hyundai i30 Hatch MY12  
Part No: 100841-WL

Tail Harness Length Required: 1200mm

Wiring Loom Installation Time: Approx 60 Mins

## Wiring Loom Fitting Instructions To Suit Hyundai i30 Hatch MY12 Part Number 100841-WL

1. Inside the luggage compartment area, remove the rear sunshade.
2. Remove the cargo hook latch covers.
3. Remove the floor carpet.
4. Fold down the rear passenger seats.
5. Remove the rear luggage compartment trim by removing the three clips by pulling in an upwards direction.
6. On the luggage compartment LHS trim, open the two fastener covers and remove the two bolts.
7. Remove the two clips and screw.
8. Disconnect the luggage compartment light connector and then peel open the luggage compartment trim.

**Repeat steps 6-8 for RHS (luggage compartment light only on LHS).**

9. Dislodge the LHS upper 'C' pillar trim.
10. At the rear RHS passenger door area, remove the under-seat trim.
11. Dislodge the 'B' pillar trim.
12. Remove the lower 'C' pillar trim by removing the clip.
13. On the front of the vehicle, on the RHS, remove the driver's scuff plate trim and fuse access panel.
14. Remove the bonnet release lever by first removing the fastener.
15. Remove the driver's kick panel trim.
16. On the rear RHS quarter of the luggage compartment area, drill a Ø30mm hole (1) into the sheet metal in the area as shown.



# TRAILBOSS

## Wiring Loom Fitting Instructions To Suit Hyundai i30 Hatch MY12 Part Number 100841-WL

17. File any rough or sharp edges and spray with rust inhibitor.
18. In the LHS of the luggage compartment, following the table below, connect the ezy-tap (1) to the vehicle 'BLUE' reverse wire (2), then connect the trailer patch terminal to the ezy-tap (1).

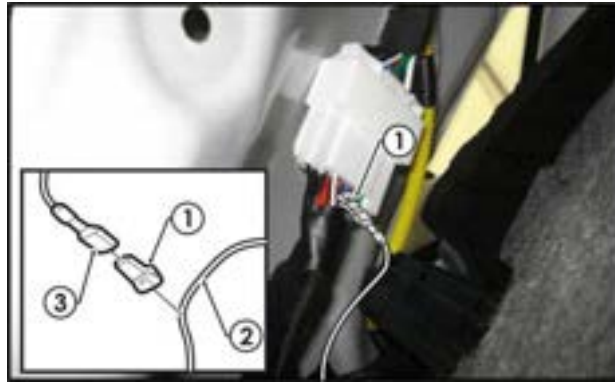

Function	Trailer Patch	Vehicle Connector
REVERSE	BLACK / WHITE	BLUE

19. On the LHS of the luggage compartment, disconnect the tail light connector and connect the trailer patch (P/No:100841-WL) connectors in between.
20. Route the trailer harness RHS connectors across the rear of the vehicle towards the RHS tail light area.
21. On the RHS of the luggage compartment area, disconnect the vehicle tail light connectors and connect the trailer patch (P/No: 100841-WL) connectors in between.
22. Secure the trailer harness ground ring terminal to a suitable location using a self tapping screw (not supplied).
23. Following the existing vehicle harness, route the 'ORANGE' power wire along the rear RHS door sill area towards the front of the vehicle.
24. Continue routing the 'ORANGE' power wire following the existing vehicle harness, towards the fuse panel.



## Wiring Loom Fitting Instructions To Suit Hyundai i30 Hatch MY12 Part Number 100841-WL

25. On the fuse panel, locate and remove the 15 Amp fuse.
26. Insert the supplied 20Amp (1) fuse and the supplied 15Amp fuse (2) to the add-a-fuse harness (3).
27. Connect the trailer patch red wire connector (4) to the add-a-fuse harness connector (5).

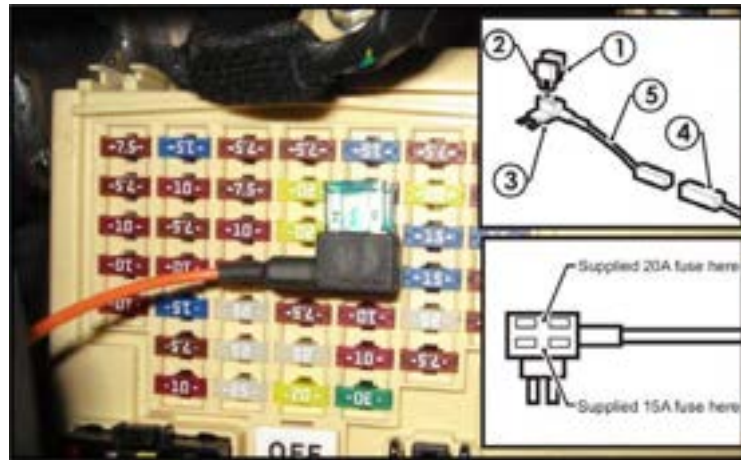

28. Insert the add-a-fuse harness (3) into the now vacant fuse location.
- Note: When placing the add-a-fuse, ensure to secure in the correct orientation as shown.**
29. Mount the trailer socket to the tow bar mounting bracket using M4 fasteners (not supplied).
  30. Route the tail harness across the tow bar towards the RHS of the vehicle and up through the previously drilled out hole.
  31. Ensure the tail harness grommet is seated correctly and secure in place using a cable tie (not supplied).
  32. Connect the tail harness (tail length 1200mm) 8-way connector to the trailer patch mating 8-way connector.
  33. Test the trailer patch function using a light board or multi meter.
  34. Secure all harnesses using cable ties (not supplied).
  35. Re-fit all removed parts and secure all fasteners, ensuring there are no squeaks or rattles.
  36. Place the fitting instructions in the glove box after fitment.