

TRAILBOSS

Towbar Fitting Instructions To Suit **HYUNDAI SONATA** Part Number **HY34L** Rating **1300/100 kg**

PLACE THESE INSTRUCTIONS IN THE VEHICLE'S GLOVEBOX AFTER INSTALLATION IS COMPLETED

WARNING:

1. Do not, drill, cut, weld or otherwise modify the tow bar.
2. If you are using electric welding on a motor vehicle, **always** check that the vehicle is not equipped with electronic engine or instrument management equipment. Failure to do so could **destroy** any onboard computers. If in doubt, check with the vehicle's manufacturer.
3. The high tensile fasteners supplied with this product were used to achieve the specified rating. If replacement is required ensure that fasteners of the same rating & quality are used. Contact an authorised **Trailboss** dealer if further information is required.
4. If TBM is used in inverted position tow ball may make contact with rear tailgate when lowered, which could cause damage.

General:

1. Ensure all hardware items have been included refer to assembly diagram.
2. It is recommended that the instructions are read through and completely understood before making any attempt to fit this product.
3. Be wary of any changes to vehicle designs or other accessories that may conflict with the installation of this product.
4. Before drilling ensure that the area is clear of fuel, electrical & other components.
5. All holes drilled into the body panels shall have all burrs & swarf removed then coated with a suitable rust preventative paint.
6. For vehicles that require the bumper to be cut. Ensure cut out area is in correct position on the vehicle prior to cutting the bumper.
7. The high tensile fasteners supplied with this product were used to achieve the specified rating. If replacement is required ensure that fasteners of the same rating & quality are used. Contact an authorized **Trailboss** dealer if further information is required.
8. Ensure that all hardware is fastened to torque list below check fasteners on regular basis.
9. Tow bar load rating sticker provided with this product shall be conspicuously located on inside rear end of the driver's door. **(See diagram below).**
10. Trailboss recommends that you check your tow ball to ensure that it complies with the Australian standards **AS 4177.2**.
11. **PLEASE NOTE:** It is advised to remove your lug or tbm when not actually towing so as to produce a clear view of the vehicles registration plate if obscured, and to also provide maximum available departure angle
12. Pull Pin must be fit in down position.

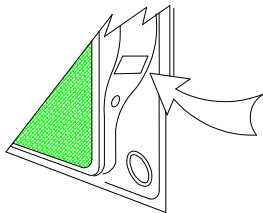

Place load rating sticker
inside driver's door here

FOR TRAILER TOWING PURPOSES ONLY
For towing capacity details please refer to vehicle owner's manual or to the manufacturer. Overloading can void your warranties.

RECOMMENDED ASSEMBLY TORQUE LISTING

Diameter	Grade 8.8 Bolt
M6	9.5 Nm
M8	21.7 Nm
M10	43.4 Nm
M12	77.3Nm
M14	146 Nm
M16	189.8 Nm

Tow bar Maintenance and Care.

Trailboss recommends that bolt torque's, as listed below, are routinely and regularly inspected and checked for correct tension. Replace any worn or defective parts.

We recommended to remove Tow Ball Mounts (TBM's, tongues or lugs) when not being used for any considerable length of time.

So as to avoid injury, when not towing it is suggested that the tongue, Pull Pin and R-clip are removed then stored in a safe, clean and dry place, away from excessive moisture.

Hitch Pull Pins and spring "R" clips are regularly checked for proper installation. Replace any worn or defective parts.

TRAILBOSS

Towbar Fitting Instructions
To Suit **HYUNDAI SONATA**
Part Number **HY34L**
Rating **1300/100 kg**

PLACE THESE INSTRUCTIONS IN THE VEHICLE'S GLOVEBOX AFTER INSTALLATION IS COMPLETED

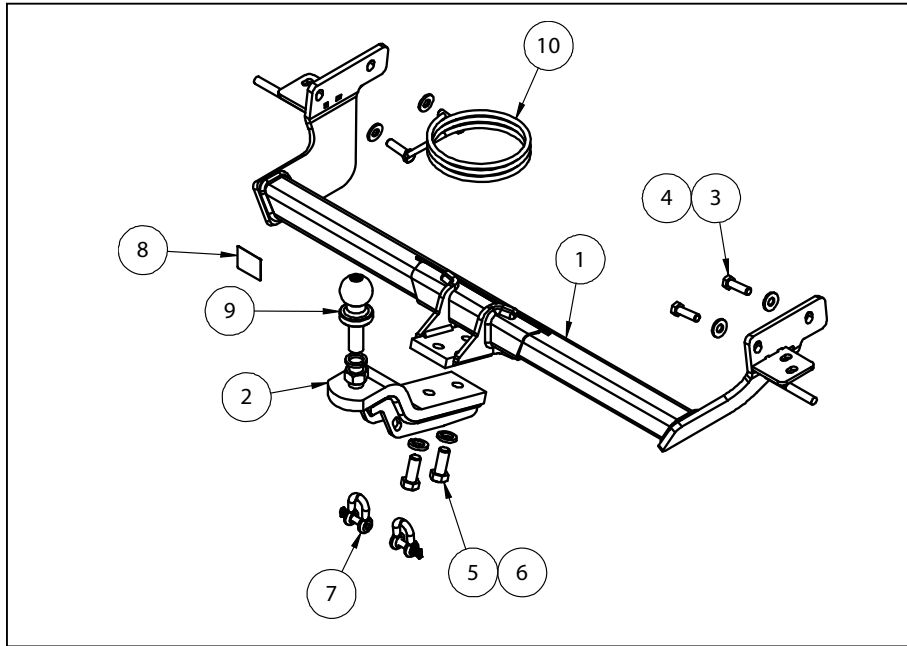

QTY.	DESCRIPTION	ITEM NO.
1	HYUNDAI SONATA WELDED ASSEMBLY	1
1	TONGUE ASSEMBLY	2
4	BOLT M12-1.25x40mm	3
4	WASHER FLAT M12	4
2	BOLT M16-2.00x40 Z/P 8.8	5
2	SPRING WASHER M16x5x3.5	6
2	10mm "D" SHACKLE	7
1	ACRYLIC CP	8
1	50mm TOWBALL	9
1	WIRING LOOM	10



Towbar Fitting Instructions
To Suit **HYUNDAI SONATA**
Part Number **HY34L**
Rating **1300/100** kg

PLACE THESE INSTRUCTIONS IN THE VEHICLE'S GLOVEBOX AFTER INSTALLATION IS COMPLETED

INSTRUCTION:

1. Open the rear tailgate.
2. Remove 4 Screws and disconnect the RHS taillight connector from inside the vehicle boot. Repeat for LHS.
3. Dislodge the RHS taillight. Repeat for LHS.
4. Remove 1 Screw and 1 Scrivet located in the RHS taillight bumper cavity. Repeat for LHS.
5. Remove 3 Screws and 2 Scrivets in the RHS wheel arch. Repeat for LHS.
6. Remove 3 Screws and 2 flange Nuts from the rear diffuser located on the underside of the bumper.
Set aside the rear diffuser.
7. Remove 1 Scrivet from the underside of the bumper on the RHS. Repeat for LHS.
8. Remove 3 Bolts from the RHS of the intrusion beam. Repeat for LHS.
9. Unclip the bumper and set aside.
10. Remove 2 flange Nuts supporting the RHS exhaust hanger.
Discard the exhaust hanger bracket but retain the flange Nuts. Repeat for LHS.
11. Remove 3 Screws from the RHS exhaust shield. Set the exhaust shield aside. Repeat for LHS.
12. Offer the main Towbar assembly to the vehicle and mount to the inside of the chassis rail via 2xM12 bolts per side.
Using the 4 flange Nuts from step 10, mount the underside of the Towbar to the vehicle studs.
Torque bolts to the following specification:
 - M12 Bolts to 98Nm
 - M8 Flange Nuts to 24Nm
13. Cut out the RHS exhaust shield. Repeat for LHS.
14. Perform a bumper cut out, refer to the template on page 5.
15. Cut out the centre of the rear diffuse.
16. Refit the exhaust shields onto the vehicle & mount the exhaust hangers to the Towbar.
17. Refit the bumper onto the vehicle.

INSTALLATION INSTRUCTIONS

PLEASE ENSURE THAT ALL INSTRUCTIONS ARE UNDERSTOOD PRIOR TO FITMENT
PLACE THESE INSTRUCTIONS IN THE VEHICLE'S GLOVEBOX AFTER INSTALLATION IS COMPLETED

HYUNDAI SONATA BUMPER CUT TEMPLATE

1. CHECK THE TEMPLATE IS TO SCALE.
2. FIND THE CENTRE OF THE BUMPER.
3. ALIGN THE CENTRELINE OF THE TEMPLATE WITH THE CENTRE OF THE BUMPER.
4. DRILL OUT THE TWO 20mm HOLES.
5. CUT ALONG THE DOTTED LINES.
6. DRILL OUT TWO 5mm HOLES FOR THE PLUG BRACKET.

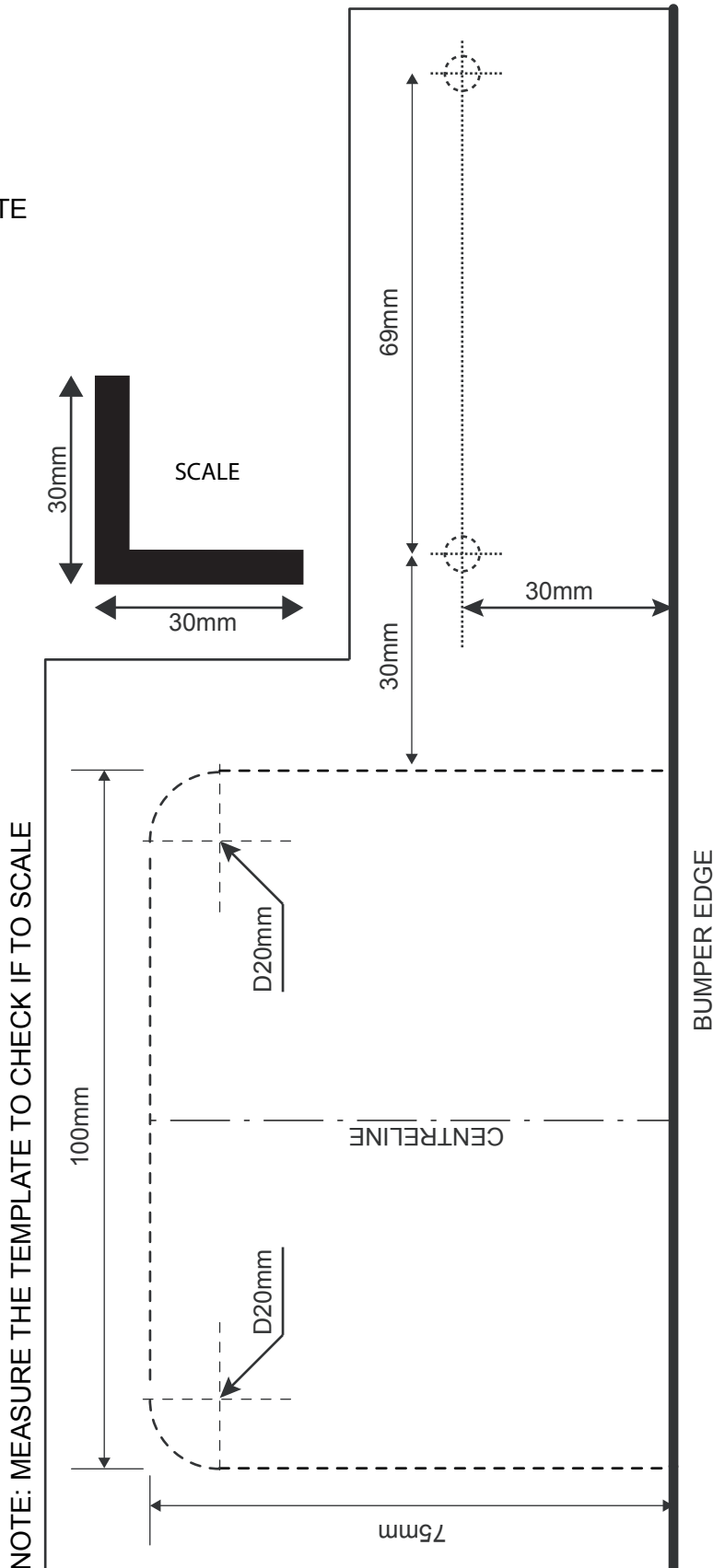



Wiring Loom Fitting Instructions
To Suit Hyundai Sonata
Part Number 101240-WL

Wiring Loom Installation Instructions

Hyundai Sonata
Part No: 101240-WL

Tail Length Required: 1200mm

Wiring Loom Installation Time: Approx 20 Mins

Important



Due to possible vehicle variations, always confirm any noted vehicle colour wires with a multi-meter to ensure the correct function is identified before soldering or scotch locking.



Wiring Loom Fitting Instructions
To Suit Hyundai Sonata
Part Number 101240-WL

1. In the luggage compartment, remove the floor cover carpet.
2. Remove the luggage compartment rear trim by removing the two clips.
3. Remove the RHS luggage compartment trim access panel.
4. Dislodge the RHS luggage compartment trim by removing the four fasteners.
Repeat for the LHS.
5. Peel open the LHS luggage compartment trim and connect the trailer patch (P/No: 101240-WL) connector to the vehicle harness mating LHS tail light connector.
6. Following the table below, connect the ezy-tap to the corresponding vehicle wire and then connect the trailer patch terminal to the ezy-tap.

Function	Trailer Patch	Vehicle Connector
REVERSE	BLACK / WHITE	BLUE

7. Route the trailer patch across to the RHS tail light area.
8. Connect the trailer patch to the RHS tail light connector.
9. In the RHS rear quarter, remove the vehicle grommet.
10. Drill the grommet hole out to Ø30mm. De-burr any sharp edges and apply rust inhibitor (not supplied). **If the grommet hole is occupied, drill in a suitable location near the existing grommet hole.**
11. Secure the trailer patch ground ring terminal to the vehicle grounding point by the RHS of the vehicle between the tail light cavity and the boot opening.
12. Mount the trailer socket to the towbar mounting bracket using M4 fasteners (not supplied).
13. Route the tail harness (tail length 1200mm) towards the RHS drilled out hole. Keep harness away from any hot surfaces or sharp objects.
14. Ensure the tail harness grommet is seated correctly and makes a good seal.
15. Secure the grommet in place using cable ties (not supplied).
16. Connect the tail harness 8-way connector to the Trailer Patch 8-way mating connector.
17. Refit tail lights.
18. Test the body harness using a light board or multi-meter.
19. Secure all harnesses using cables ties (not supplied).
20. Re-fit all removed parts and secure all fasteners.
21. Place instructions in glove box after fitment.