

# TRAILBOSS

## Towbar Fitting Instructions To Suit KIA CERATO SEDAN YD CL2 Part Number KM21L Rating 1200/75 kg

PLACE THESE INSTRUCTIONS IN THE VEHICLE'S GLOVEBOX AFTER INSTALLATION IS COMPLETED

### WARNING:

1. Do not, drill, cut, weld or otherwise modify the tow bar.
2. If you are using electric welding on a motor vehicle, **always** check that the vehicle is not equipped with electronic engine or instrument management equipment. Failure to do so could **destroy** any onboard computers. If in doubt, check with the vehicle's manufacturer.
3. The high tensile fasteners supplied with this product were used to achieve the specified rating. If replacement is required ensure that fasteners of the same rating & quality are used. Contact an authorised **Trailboss** dealer if further information is required.
4. If TBM is used in inverted position tow ball may make contact with rear tailgate when lowered, which could cause damage.

### General:

1. Ensure all hardware items have been included refer to assembly diagram.
2. It is recommended that the instructions are read through and completely understood before making any attempt to fit this product.
3. Be wary of any changes to vehicle designs or other accessories that may conflict with the installation of this product.
4. Before drilling ensure that the area is clear of fuel, electrical & other components.
5. All holes drilled into the body panels shall have all burrs & swarf removed then coated with a suitable rust preventative paint.
6. For vehicles that require the bumper to be cut. Ensure cut out area is in correct position on the vehicle prior to cutting the bumper.
7. The high tensile fasteners supplied with this product were used to achieve the specified rating. If replacement is required ensure that fasteners of the same rating & quality are used. Contact an authorized **Trailboss** dealer if further information is required.
8. Ensure that all hardware is fastened to torque list below check fasteners on regular basis.
9. Tow bar load rating sticker provided with this product shall be conspicuously located on inside rear end of the driver's door. **(See diagram below)**.
10. Trailboss recommends that you check your tow ball to ensure that it complies with the Australian standards **AS 4177.2**.
11. **PLEASE NOTE:** It is advised to remove your LUG or TBM when not actually towing so as to produce a clear view of the vehicles registration plate if obscured, and to also provide maximum available departure angle

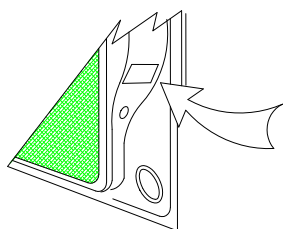

Place load rating sticker  
inside driver's door here

**FOR TRAILER TOWING PURPOSES ONLY**  
For towing capacity details please refer to vehicle owner's manual or to the manufacturer. Overloading can void your warranties.

### RECOMMENDED ASSEMBLY TORQUE LISTING

Diameter	Grade 8.8 Bolt
M6	9.5 Nm
M8	21.7 Nm
M10	43.4 Nm
M12	77.3Nm
M14	146 Nm
M16	189.8 Nm

### Tow bar Maintenance and Care.

Trailboss recommends that bolt torque's, as listed below, are routinely and regularly inspected and checked for correct tension. Replace any worn or defective parts.

We recommended to remove Tow Ball Mounts (TBM's, tongues or lugs) when not being used for any considerable length of time.

So as to avoid injury, when not towing it is suggested that the tongue, Pull Pin and R-clip are removed then stored in a safe, clean and dry place, away from excessive moisture.

Hitch Pull Pins and spring "R" clips are regularly checked for proper installation. Replace any worn or defective parts.

**Cequent Customer Service**  
Ph: 1800 812 017 Fax: 03 9898 3299  
Email: info@cequent.com.au  
Post: PO Box 4050, Dandenong South VIC 3175

# TRAILBOSS

Towbar Fitting Instructions  
 To Suit **KIA CERATO SEDAN YD CL2**  
 Part Number **KM21L**  
 Rating **1200/75 kg**

PLACE THESE INSTRUCTIONS IN THE VEHICLE'S GLOVEBOX AFTER INSTALLATION IS COMPLETED

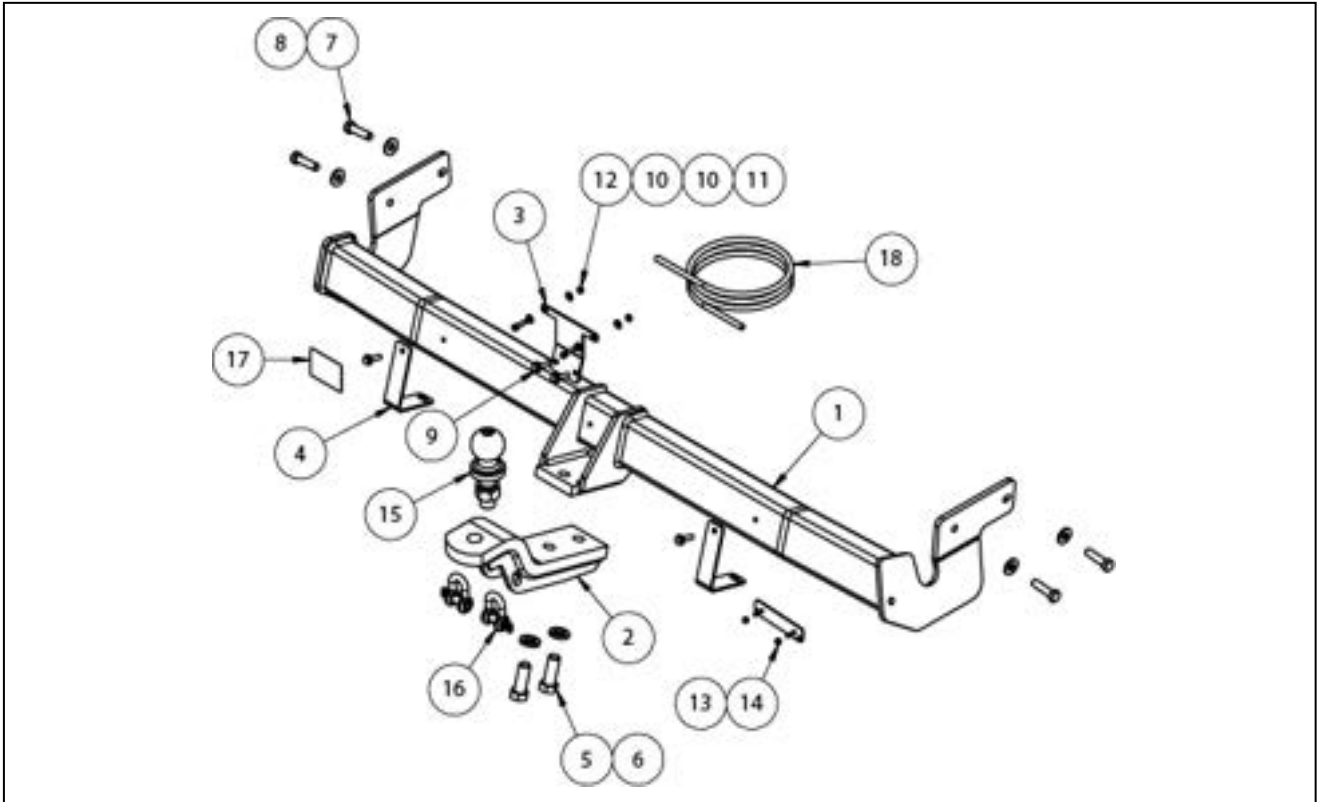

ITEM NO.	DESCRIPTION	QTY.
1	KIA CERATO YD MY17 CL2 WELDED ASSY	1
2	TONGUE ASSEMBLY	1
3	SENSOR TAB	1
4	BUMPER TAB	2
5	BOLT M16x45 2.0P	2
6	SPRING WASHER M16x5x3.5	2
7	M10x45x1.25P GRADE 10.9	4
8	WASHER FT M10x25.4x3	4
9	TEK SCREW 14-22 HEX HD 22MM	4
10	WASHER FLAT M6x12.5x1.2	4
11	SET SCREW HEX HD M5x20x0.8P	2
12	NUT NYLOC M5-0.8Z/P	2
13	PLUG BRACKET	1
14	NUT NYLOC M4-0.7Z/P	2
15	TOWBALL 50MM	1
16	"D" SHACKLE 10MM	2
17	ACRYLIC COMPLIANCE LABEL	1
18	WIRING LOOM	1

**Cequent Customer Service**  
 Ph: 1800 812 017 Fax: 03 9898 3299  
 Email: info@cequent.com.au  
 Post: PO Box 4050, Dandenong South VIC 3175

Towbar Fitting Instructions  
To Suit KIA CERATO SEDAN YD CL2  
Part Number KM21L  
Rating 1200/75 kg

PLACE THESE INSTRUCTIONS IN THE VEHICLE'S GLOVEBOX AFTER INSTALLATION IS COMPLETED

1. Open boot and remove the rear light access panels located on the LH and RH sides of the boot cavity.



2. From inside the newly exposed section, remove 4x nuts securing tail light to rear panel.
  3. Disconnect wiring harness (white plug) and carefully remove tail light.
- Repeat for opposite side of vehicle.



4. Remove 1x scrivet and 1x screw from light cavity.
- Repeat for opposite side of vehicle



**Cequent Customer Service**  
Ph: 1800 812 017 Fax: 03 9898 3299  
Email: [info@cequent.com.au](mailto:info@cequent.com.au)  
Post: PO Box 4050, Dandenong South VIC 3175

Towbar Fitting Instructions  
To Suit KIA CERATO SEDAN YD CL2  
Part Number KM21L  
Rating 1200/75 kg

PLACE THESE INSTRUCTIONS IN THE VEHICLE'S GLOVEBOX AFTER INSTALLATION IS COMPLETED

5. On LH side inside boot, remove 3x scrivenets securing boot lining to the body.



6. On the LH side, peel away boot lining to expose the harness connector. Reach in and disconnect the plug.



7. Remove 3x screws and 1x scrivet located inside the rear wheel well.

Repeat for opposite side of vehicle



**Cequent Customer Service**  
Ph: 1800 812 017 Fax: 03 9898 3299  
Email: [info@cequent.com.au](mailto:info@cequent.com.au)  
Post: PO Box 4050, Dandenong South VIC 3175

# TRAILBOSS

Towbar Fitting Instructions  
To Suit KIA CERATO SEDAN YD CL2  
Part Number KM21L  
Rating 1200/75 kg

PLACE THESE INSTRUCTIONS IN THE VEHICLE'S GLOVEBOX AFTER INSTALLATION IS COMPLETED

8. Remove 9x scrivets located under and along the width of the bumper.



9. Under vehicle on LH side, remove 4x nuts and remove the tyre well protector.



10. From underneath vehicle, remove 4x bolts (2 per side) securing bumper assembly (impact beam) to vehicle rear panel.

Ensure you have a suitable area to place the bumper assembly prior to removal.

Carefully peel away from the sides and remove bumper assembly from vehicle. Ensure any bumper related sensor harnesses are disconnected.



**Cequent Customer Service**  
Ph: 1800 812 017 Fax: 03 9898 3299  
Email: [info@cequent.com.au](mailto:info@cequent.com.au)  
Post: PO Box 4050, Dandenong South VIC 3175



Towbar Fitting Instructions  
To Suit KIA CERATO SEDAN YD CL2  
Part Number KM21L  
Rating 1200/75 kg

PLACE THESE INSTRUCTIONS IN THE VEHICLE'S GLOVEBOX AFTER INSTALLATION IS COMPLETED

11. Remove 2x scrivenets securing the impact beam to the top of bumper.

Remove and dispose the impact beam.



12. Mount towbar assembly to vehicle, secure with 4 x M10 bolts complete with washer.

**Torque all bolts to 68Nm.**



13. Mount supplied brackets to outermost holes on towbar crosstube using supplied self-tapping screws, to allow for connection to bumper upon reassembly

14. If vehicle is mounted with a keyless entry sensor, install sensor onto supplied plate (facing rearwards) and mount the plate with self-tapping screws to central section of towbar.

**CAUTION**

**Do not overtighten screws as they may break and render installation onto towbar difficult.**



**Cequent Customer Service**

Ph: 1800 812 017 Fax: 03 9898 3299

Email: [info@cequent.com.au](mailto:info@cequent.com.au)

Post: PO Box 4050, Dandenong South VIC 3175

Towbar Fitting Instructions  
To Suit KIA CERATO SEDAN YD CL2  
Part Number KM21L  
Rating 1200/75 kg

PLACE THESE INSTRUCTIONS IN THE VEHICLE'S GLOVEBOX AFTER INSTALLATION IS COMPLETED

- 15.** Working on the inside and bottom edge of the bumper, locate the centre of the bumper and mark out the bumper cut as depicted.

The initial 25mm is measured from the bottom edge (centre of bumper tab hole).

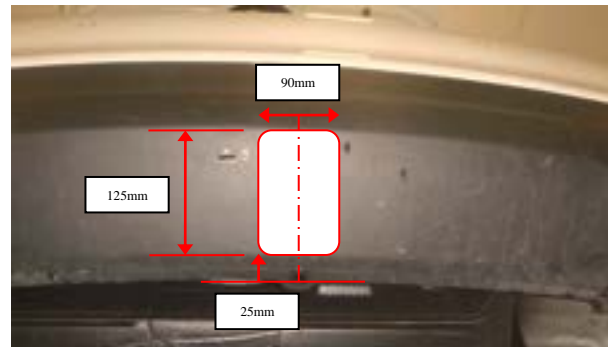

- 16.** At an appropriate position on the bumper, mark out and drill 2x  $\varnothing$ 5mm holes 69mm apart on bumper skin to support plug bracket.

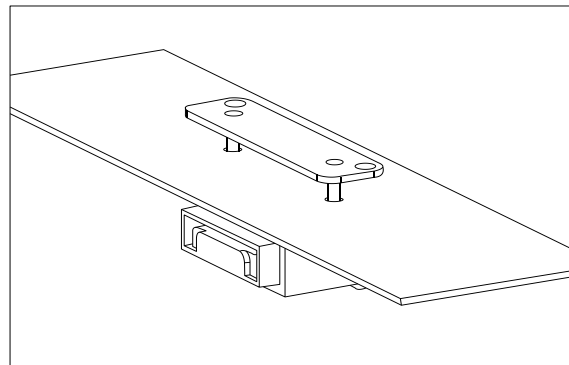

- 17.** Fit bumper to the vehicle and follow steps 1 – 9 in reverse order to complete the installation.

**Cequent Customer Service**  
Ph: 1800 812 017 Fax: 03 9898 3299  
Email: [info@cequent.com.au](mailto:info@cequent.com.au)  
Post: PO Box 4050, Dandenong South VIC 3175