

PRODUCT DETAILS:

| | | | | |
|--------------------------------------|-------|----------------------------------|------|----|
| Part Number: | KM23L | Maximum Towing Braked: | 1200 | kg |
| ECU Number: | 04836 | Maximum Towing Unbraked: | 610 | kg |
| Tail Harness Length Required: | 04936 | Maximum Static Ball Load: | 75 | kg |
| TBM/Lug Part Number: | 07756 | | | |

FITTING DETAILS:

| | | | |
|----------------------------------|----------|--|-----|
| Towbar Installation Time: | 70 Mins. | RPA Disable/Other Notes: | YES |
| Total Installation Time: | 70 Mins. | Note: | |
| Bumper Cut Required: | Yes | <ul style="list-style-type: none">• RPA Disable - Harness 04936 must be used and connected• Electric Brake Input Location: Near ECU connector | |

TRAILBOSS RECOMMENDS THAT INSTRUCTIONS ARE READ AND UNDERSTOOD COMPLETELY PRIOR TO FITMENT.

BEFORE YOU START:

Check all hardware items have been included refer to assembly diagram.
Please ensure this towbar is only fitted to vehicle models as per Trailboss application guide.

Bumper Cuts

Vehicle and bumper variations can and do occur during vehicle manufacture after initial towbar design. Fitment of towbar to vehicle and accuracy of bumper cut must be assessed prior to any bumper modifications made. Incorrect bumper cuts are not covered under Trailboss warranty.

NOTE: Bumper cuts need to be approached with care, refer to notes below.

- Bumper centreline – where the centreline of the bumper needs to be determined, the installer must assess centre point by measurement of bumper width or determining two symmetrical reference points to give centreline.
- Bumper edge – To assist with accurate bumper cut measurement, reference to the start of the bumper edge is now being commonly used.
 - Measure from bottom edge along bumper and around corner to the 70 mm point (Figure 1).
 - Do not measure from visible bumper front of corner, upwards (Figure 2).

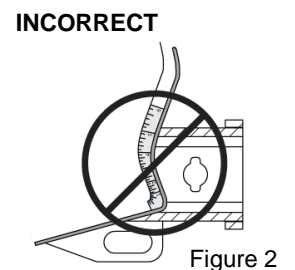
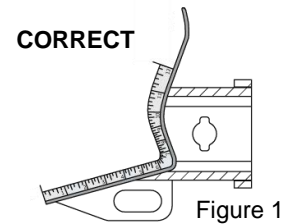

Drilling

- For any required drilling during installation, ensure that the area is clear of fuel, electrical & other components that may be damaged.
- All holes drilled into metal body panels shall have all burrs & swarf removed then coated with a suitable rust preventative paint.

Bolts/Fasteners

- Ensure that all hardware is fastened to correct torque as specified in this fitting instruction.
- All fasteners supplied with this product are used to achieve a specified clamp loading. If replacement is required ensure that fasteners of the same grade and class are used.

NOTE: Achieving correct torque is critical to proper installation and responsibility of the installer. Towbar failures attributed to tension issues from over tightening or under tightening are not covered by Trailboss warranty.

Product Labels

- a. Towbar load rating sticker provided with this product shall be conspicuously located on inside rear end of the driver's door.

WARNING:

Do not, drill, cut, weld or otherwise modify the towbar.

FOR TOWING PURPOSES ONLY - This towbar is designed and tested by Trailboss to adhere to ADR 62/02 which provides only for the expected load demands of towing.

i TOWBAR ASSEMBLY DIAGRAM

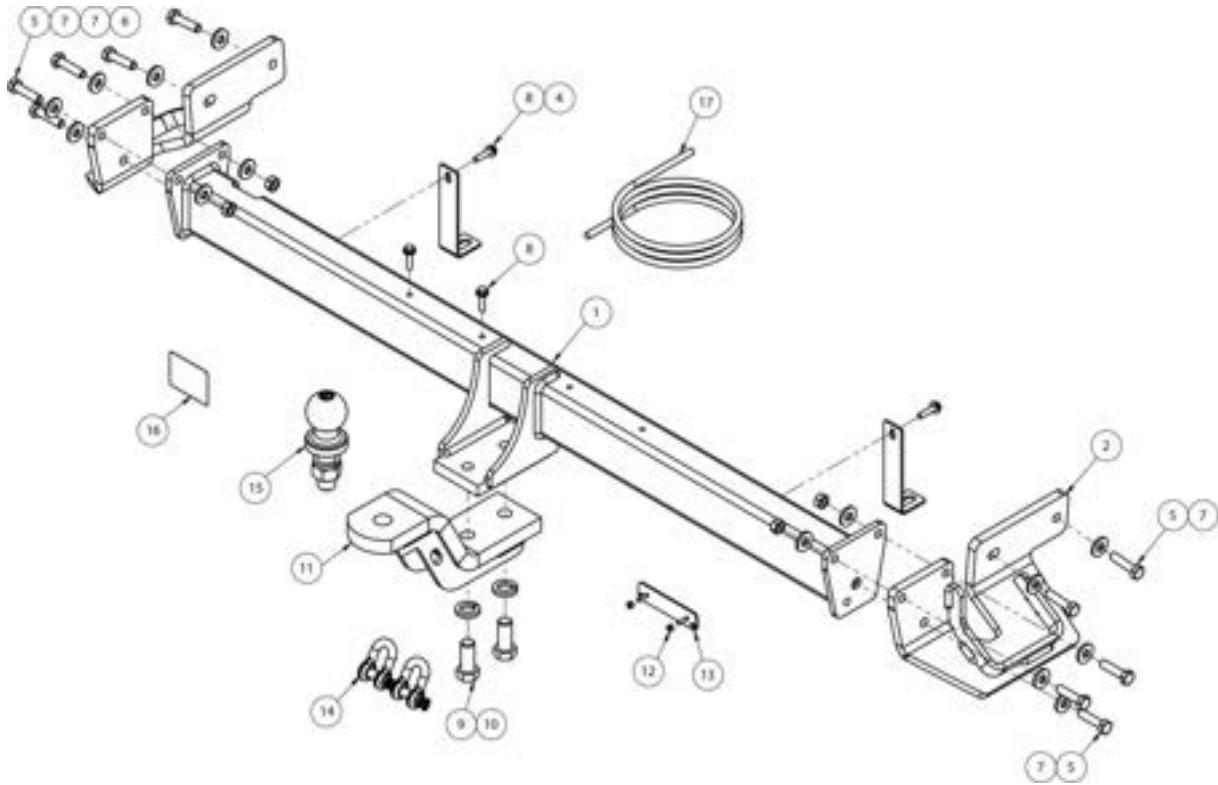

| ITEM | DESCRIPTION | QTY |
|------|-------------------------------|-----|
| 1 | KIA CERATO WELDED ASSEMBLY | 1 |
| 2 | RH SIDE ARM ASSEMBLY | 1 |
| 3 | LH SIDE ARM ASSEMBLY | 1 |
| 4 | BUMPER TAB | 2 |
| 5 | SET SCREW HEX HD M10x40x1.25P | 10 |
| 6 | NUT HEX HD M10x1.25P | 4 |
| 7 | WASHER PLAIN M10 | 14 |
| 8 | TEK SCREW 14-20 HEX HD 22mm | 4 |
| 9 | SET SCREW HEX M16x40x2.0P | 2 |

| ITEM | DESCRIPTION | QTY |
|------|----------------------------|-----|
| 10 | SPRING WASHER M16 | 2 |
| 11 | LUG ASSY | 1 |
| 12 | NUT NYLON LOCK HEX M4X0.7P | 2 |
| 13 | PLUG BRACKET | 1 |
| 14 | 10mm "D" SHACKLE | 2 |
| 15 | 50mm TOWBALL | 1 |
| 16 | ACRYLIC COMPLIANCE LABEL | 1 |
| 17 | WIRING LOOM | 1 |

1. Open boot and remove LH and RH side panel trims from inside boot to expose rear of tail-light.

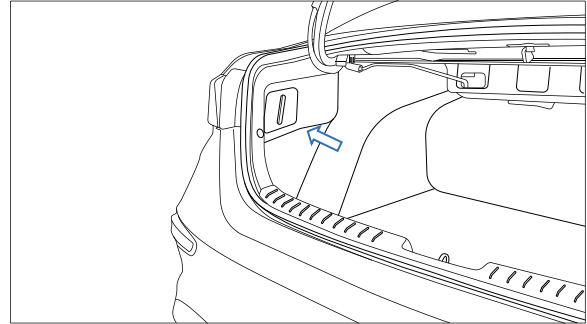

2. Remove 4 x hex nuts securing tail-light to vehicle. Gently pull tail-light rearwards to dislodge and unclip attached wiring from inside vehicle and feed through rear panel. Set tail-light aside.

Repeat for opposite side.

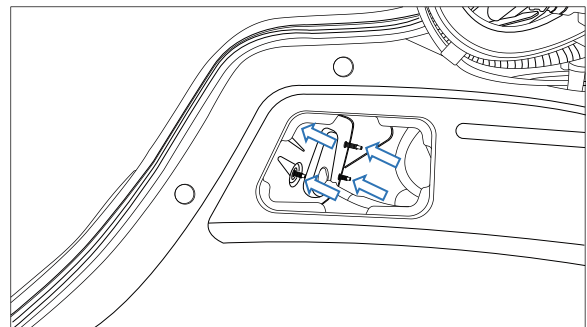

3. Remove 1 x screw and 1 x scrivet from top of bumper where tail-light was removed.

Repeat for opposite side.

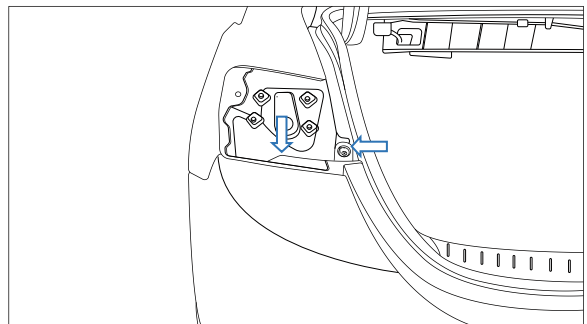

-
4. For single exhaust, remove trim from underside of vehicle by removing 3 x scrivenets and 3 x hex nuts.

Set trim aside.

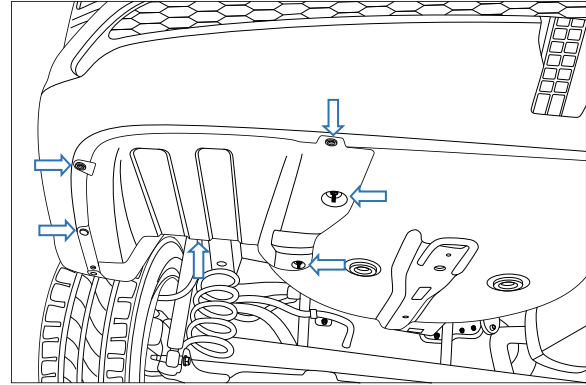

-
5. Inside rear wheel arch, remove 2 x screws and 2 x scrivenets (one on the underside of vehicle).

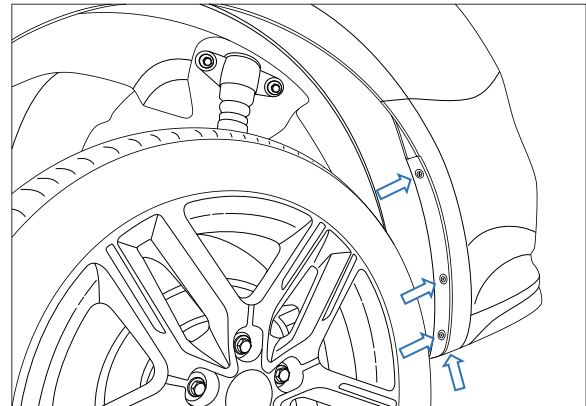

-
6. Remove 2 x hex head bolts on each side of vehicle securing impact beam to rear panel. These can be accessed from the underside of the vehicle.

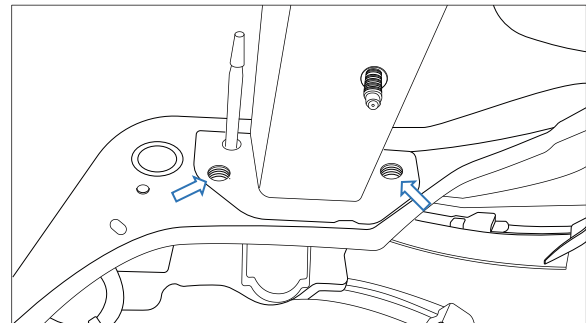

-
- Carefully peel back bumper from corners to remove. Disconnect wiring harness from rear panel to free the bumper.

Set bumper safely aside.

-
- Remove 5 x scrivenets securing impact beam to bumper.

Disconnect any wiring connections between the impact beam and the bumper. Remove impact beam from bumper with wiring still attached.

Remove all wiring from impact beam.

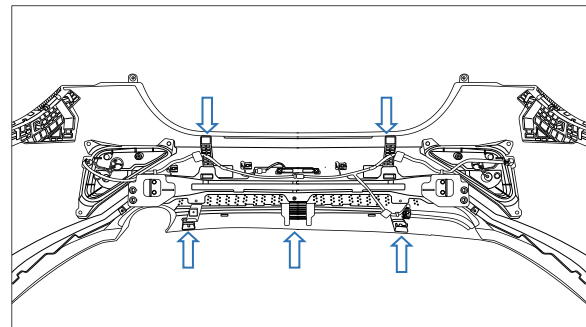

-
- Re-attach removed wiring to bumper and secure in place with cable ties (not supplied). Disconnect antenna from impact beam. This will be reattached to the towbar later.

Discard impact beam.

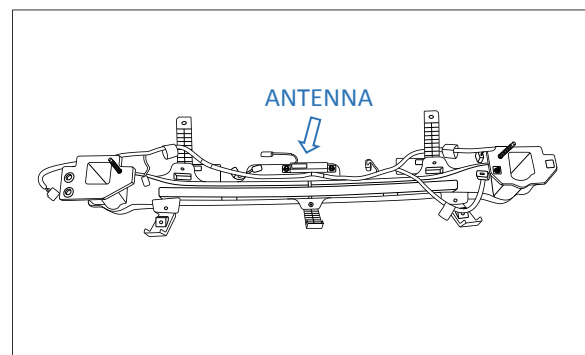

10. If required, remove exhaust from rear exhaust hanger to allow better access for fitment.

Note: Repeat for opposite side if fitting a dual exhaust model.

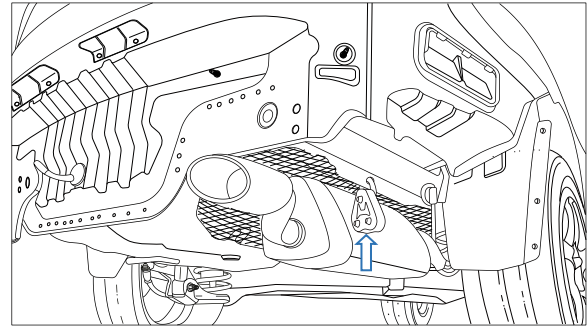

11. Attach supplied bumper tab brackets to front face of towbar (refer to exploded diagram on page 3) with 1 x tek screw per bracket.

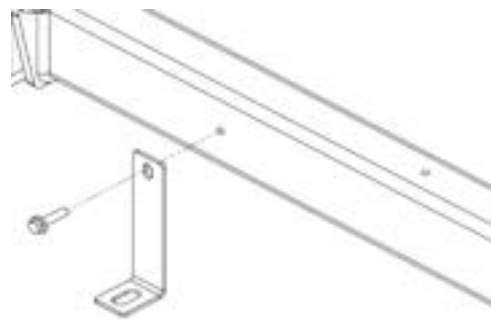

12. Loosely secure side arm to outboard side of chassis rail via 2 x M10 bolts complete with 1 x M10 washer per bolt.

Repeat for opposite side.

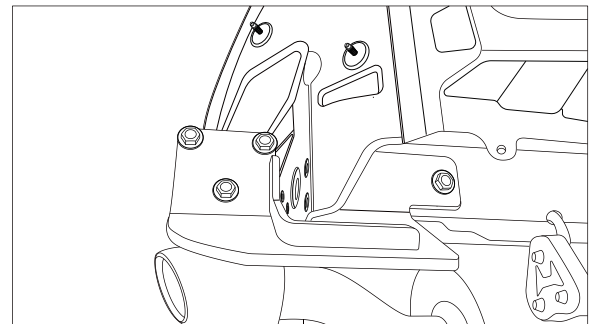

13. Loosely secure welded centre section to side arms via 2 x M10 bolts complete with 2 x M10 washers and 1 x M10 nut per bolt.

Secure side arms to weld nuts on centre section via 1 x M10 bolt complete with 1 x M10 washer.

Repeat for opposite side.

Tighten all bolts to the following torques:

M10 x 1.25 – 48 N.m

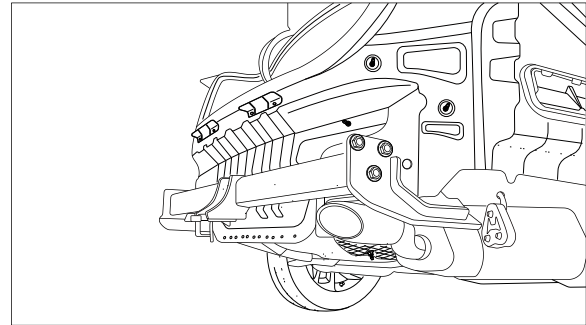

14. Re-fit the antenna removed in Step 9 to the two holes located on the top of the cross-tube with 2 x tek screws supplied. Ensure to not overtighten fasteners.

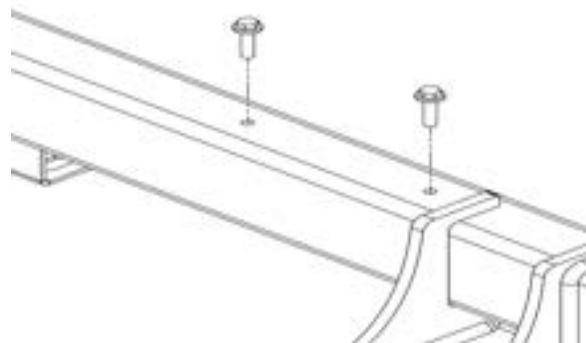

15. Identify the centre line of the bumper. Measure 100mm up from the bottom edge of the bumper. From there, mark and cut a 100mm tall (up to the first style line on the bumper) x 100 mm wide square (as measured either side of the bumper centreline).

Ensure to remove any sharp edges or burrs from bumper after cut.

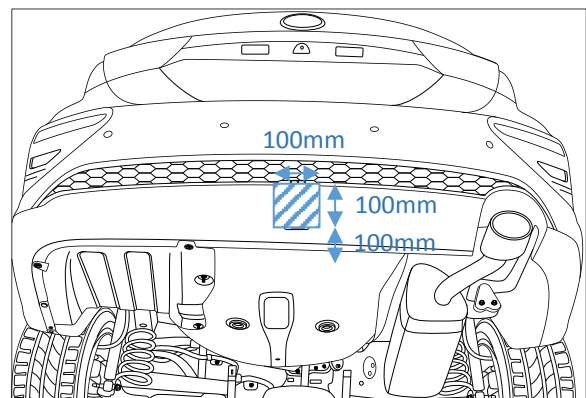

IMPORTANT

Due to possible vehicle variations, always confirm any noted vehicle colour wires with a multi-meter to ensure the correct function is identified before soldering or scotch locking. For vehicle wires denoted with two colours (example; RED/GREEN) the first colour will always be the main wire colour while the second colour is the thinner trace colour on the wire.

16. In the engine bay, disconnect the vehicle battery negative terminal (1).

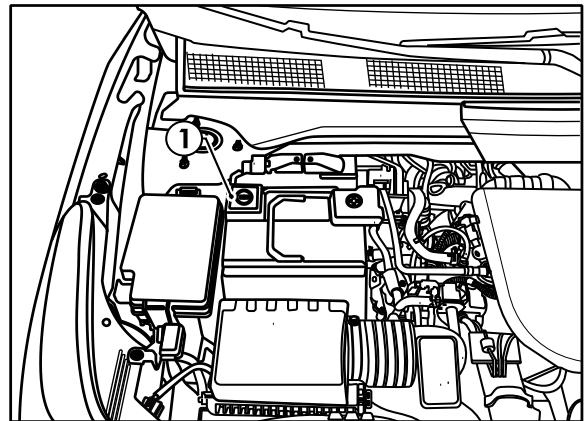

17. In the boot, remove the rear sunshade (1).

18. Fold down the rear seats (2).

19. Remove the floor carpet (3).

20. Remove the foam storage tray.

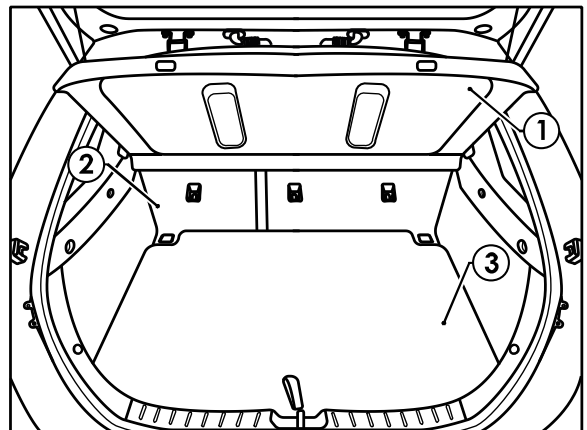

21. Remove the rear scuff trim (1) by first removing the trim clips (2), and then pulling in an upwards direction.

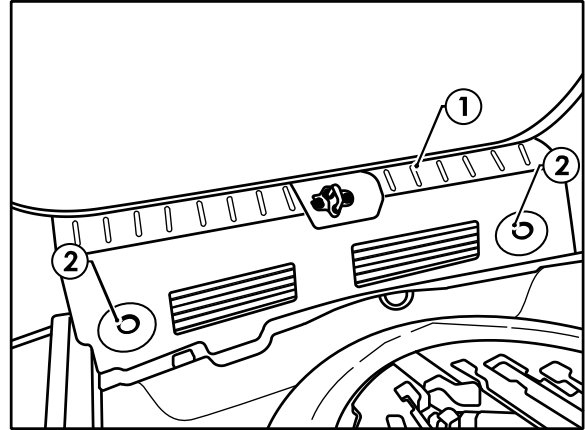

22. Remove the RHS tool tray (1) by releasing the Phillip's Head screws (2).

23. On the RHS trim, remove the caps (3) to expose the 10mm bolts.

24. Remove the 10mm bolts and trim clip (4).

25. Remove the final screw (under the RHS tool tray) securing the RHS trim.

26. Dislodge the RHS trim.

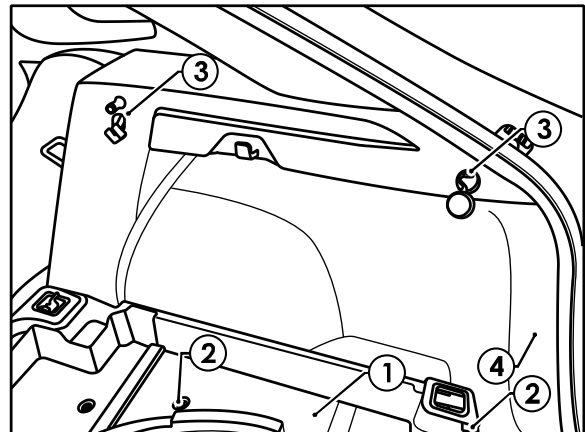

27. On the RHS floor, locate the 25mm blanking grommet (1).

28. Remove the blanking plug and drill hole out to 30mm.

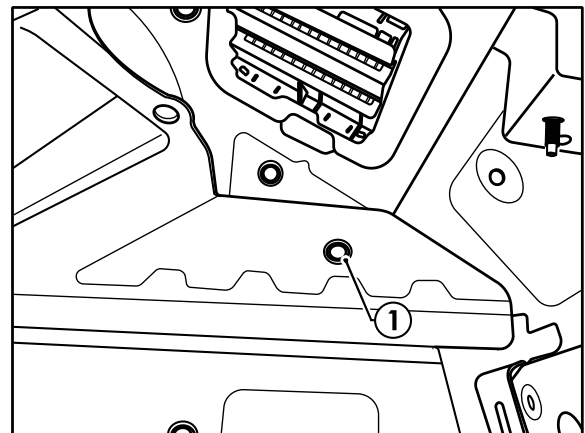

29. Route the white and blue connector on the larger trailer patch harness (102111-WL) (1) from the inside of the vehicle through the drilled grommet hole (2) to the outside.

30. Seat grommet (2) in hole.

Note: Keep harness routing clear of all sharp edges, moving parts and places of extreme heat.

Note: Ensure grommet is seated correctly and makes a good seal.

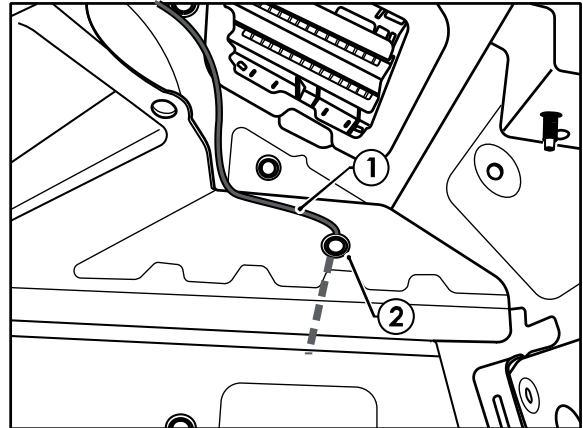

31. At the RHS tail light, patch in the harness connectors (1) in between the vehicle harness (2) and the tail light harness (3).

32. Using the supplied M6 flange nut, secure the star ring terminal (4) to the vehicle stud (5).

Note: Ensure the star ring terminal bites into the chassis to provide a clean earth connection.

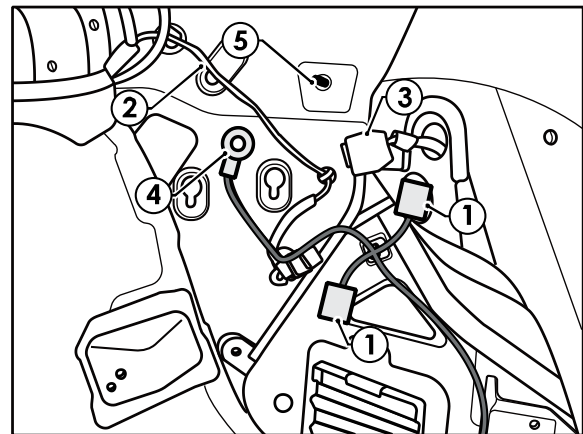

33. Using an alcohol wipe, clean a suitable sheet metal area (1) and the underside of the ECU (04836) (2).

34. Connect the trailer patch 12-way connector (3) to the ECU.

35. Apply double sided tape to the ECU (2) and secure it to the vehicle sheet metal.

Note: Mount the ECU, ensuring the connector is orientated downwards.

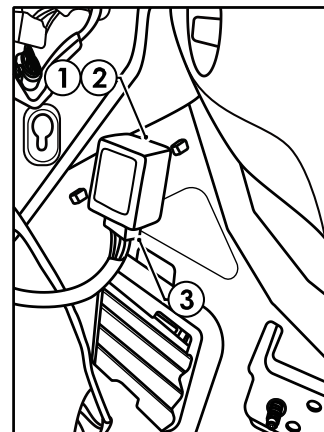

36. From the RHS passenger door, remove a small section of the weather seal (1).

37. Dislodge the trim (2) covering the rear passenger seatbelt.

38. Route the power wire from the boot towards the front of the vehicle.

Note: Use the supplied Cable Ties to secure the harness away from the seat belt.

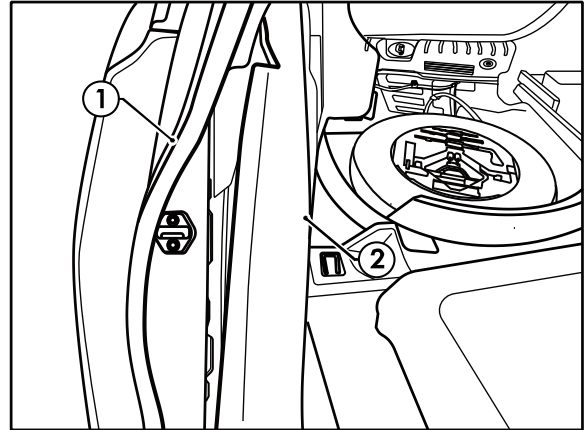

39. Continue routing the power wire (1) towards the fuse box (2) at the RHS kick panel, tucking the wire under the trim.

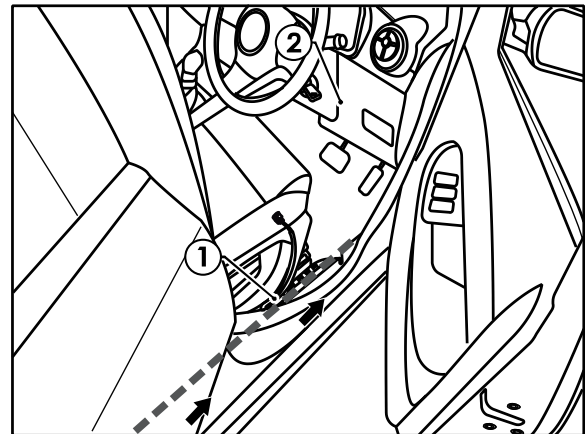

40. Dislodge the RHS kick panel trim (1) and the fuse box cover (2).

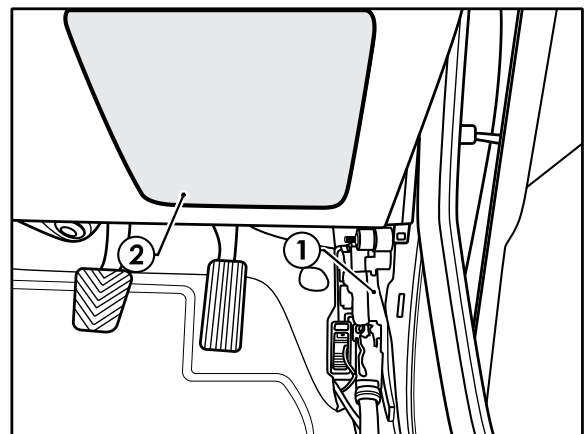

41. Remove Vehicle 20 amp fuse from location Fuse 14.

42. Insert the supplied 20 amp fuse (1) into the Add- A-Fuse (2) top slot and then insert the vehicle fuse (3) into the bottom slot.

43. Insert the Add-A-Fuse (2) to the blank fuse location in the orientation shown (4).

44. Connect the Add-A-Fuse (2) to the main harness (5).

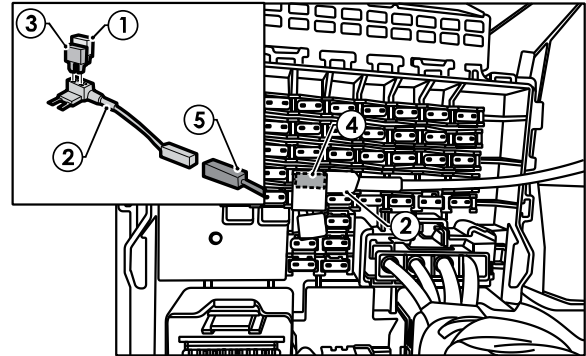

Note: To maintain correct electrical operation, ensure you insert the fuse adaptor into the allocated slot and in the orientation shown.

45. Connect the small T-patch harness in between the bumper connector and vehicle connector.

46. With the rear bumper removed, secure tail harness and small T-patch to towbar.

47. Route tail harness and T-patch along towbar to the RHS.

Keep harness routing clear of all sharp edges, moving parts and places of extreme heat.

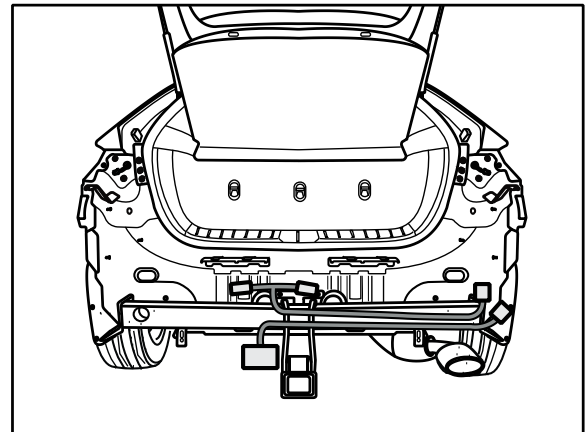

48. Connect the tail harness (part number 04936) 8-way connector (1) to the trailer patch mating 8-way connector (2).

49. Connect the T-patch harness 3-way connector to the trailer patch mating 3-way connector.

50. Cut-off, crimp the tail harness GREY and GREY/BLACK wires (3) to the trailer patch matching WHITE and GREY/BLACK wires (4).

51. Apply silicone grease (not supplied) (5) to waterproof the blue connector.

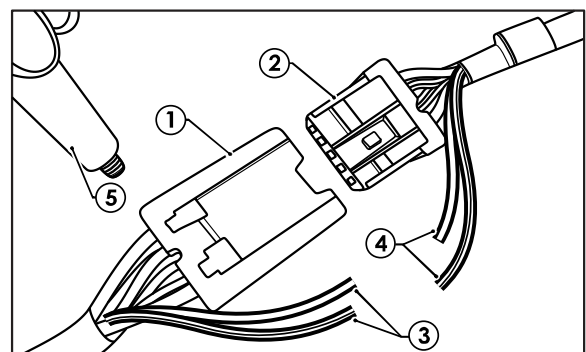

-
52. Secure all harnesses using supplied Cable Ties.
 53. Test the trailer patch function using a light board or multi-meter.
 54. Re-fit all removed parts and secure all fasteners, ensuring there are no squeaks or rattles.

55. Mark out and drill 2 x \varnothing 5mm holes 69mm apart on bumper skin to support plug bracket.

56. Remove centre bumper tab from bumper.

57. Refit all removed components. Attach bumper to towbar tabs via 2 x scrivenets accessed from the underside of the vehicle.

58. Place the fitting instructions in the glove box after fitment.

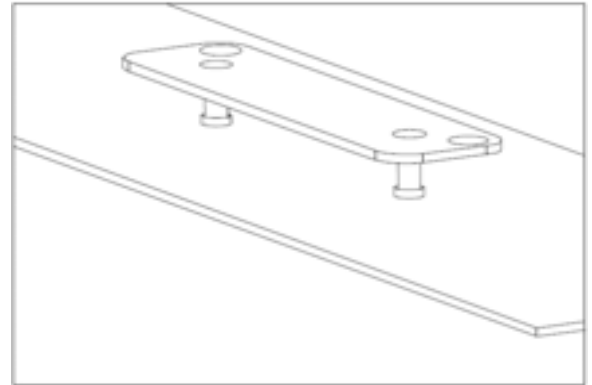



CUSTOMER INFORMATION

PLACE THESE INSTRUCTIONS IN THE
VEHICLE'S GLOVEBOX AFTER INSTALLATION

**THANK YOU FOR PURCHASING TRAILBOSS. WITH CORRECT MAINTENANCE AND CARE
THIS PRODUCT WILL PROVIDE A LIFETIME OF TROUBLE-FREE OPERATION.**

TOWBAR MAINTENANCE AND CARE:

1. Trailboss recommend that the towbar LUG or TBM (Trailer Ball Mount) Pull Pin and R-clip are removed and stored when not in use. Removal of LUG or TBM (Trailer Ball Mount) is advisable when not in use to assist with any of the following.
 - Ensure rear number plate is not obscured.
 - Allow maximum available departure angle and prevent any potential interference.
 - Prevent possible interference with vehicles reverse sensors or camera detecting a tow ball mount as an obstruction during reversing.
 - Removes towball mount as an obstruction for when moving around the rear of the vehicle.
2. Trailboss recommends routine inspection of your towbar to ensure trouble free towing.
 - Bolt security and tension should be regularly inspected and checked for correct tension. Replace any worn or defective parts with suitable grade & class fasteners. Inspection should be requested to coincide with vehicle major services.
3. It is the owner's responsibility to ensure towing and down ball weight capacities of the towing vehicle are not exceeded.
 - Towing and down ball weights allowable may differ according to model variations. Please refer to owner's manual or vehicle dealer to confirm exact rating for your vehicle model variant.
 - It is not uncommon for the vehicle tow rating to differ from the towbar rating. When this occurs, the lesser rating must be adhered to.
 - For vehicles fitted with enhanced vehicle functions that may be altered/changed when towing i.e Trailer sway mitigation, blind spot detection, adaptive cruise control etc. Please consult owner's manual to understand changes enabled when towing and after towing.

WARRANTY INFORMATION:

Trailboss Towbars are covered by a Lifetime Warranty.

Our goods come with guarantees that cannot be excluded under the Australian Consumer Law. You are entitled to a replacement or refund for a major failure and for compensation for any other reasonably foreseeable loss or damage. You are also entitled to have the goods repaired or replaced if the goods fail to be of acceptable quality and the failure does not amount to a major failure.

For further details please contact customer service on 1800 812 017.

PRO SERIES SILENT ANTI-RATTLE HITCH PIN

Your Trailboss towbar is equipped with a Pro Series Silent Anti-Rattle Hitch Pin technology to help reduce towbar tongue rattle in most driving conditions. Please ensure below instructions are understood and routine maintenance is carried out to ensure best towing experience.

Regularly inspect for wear and check the tightness of the Silent Anti-Rattle Hitch Pin. Follow instructions below to re-tighten the nut as necessary when movement and noise in the tow ball mount is noted.

- Before towing, ensure R-Clip is properly installed and hitch pin nut is installed and tensioned. Replacement parts are available from your Pro Series Distributor.

TOWBALL MOUNT REMOVAL/INSTALLATION

STEP 1

Insert Trailer Ball Mount (TBM) (a) into towbar hitchbox (b), aligning hole in TBM shank (c) with hole in hitchbox (d) (Fig. 1)

STEP 2

Insert Silent Anti-Rattle Hitch Pin (e) through hole in hitchbox and hole in TBM shank (g); ensure the locators are inserted into the notches in the hitchbox (Fig. 2)

STEP 3

Screw Silent Anti-Rattle Hitch Pin (f) onto Smart Pin (g); tighten Smart Pin Nut until finger tight, ensuring TBM is restrained from up and down movement.

STEP 4

Tighten Silent Anti-Rattle Hitch Pin Nut by turning nut a further 1/8th of a turn in the clockwise direction using a 24mm spanner (Fig. 4).

STEP 5

Install Silent Anti-Rattle Hitch Pin R-Clip through the hole that provides best clearance or easiest access. (Fig. 5)

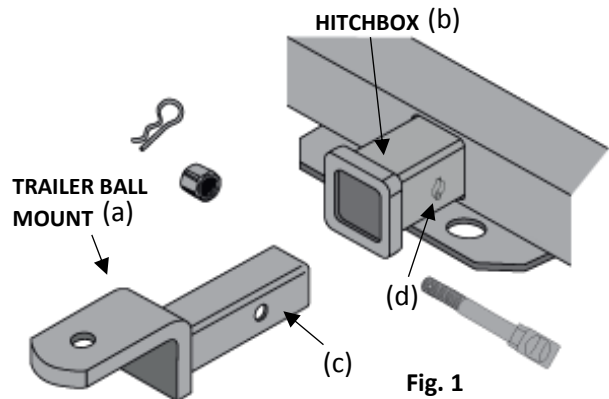

Fig. 1

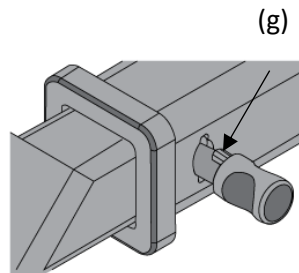

Fig. 2

SILENT ANTI-RATTLE HITCH PIN NUT (f)

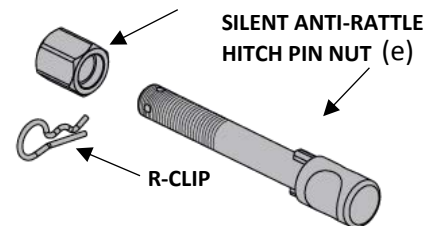

Fig. 3

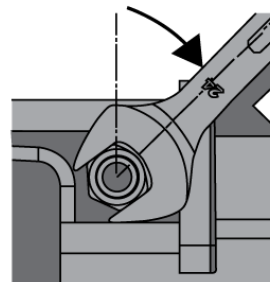

Fig. 4

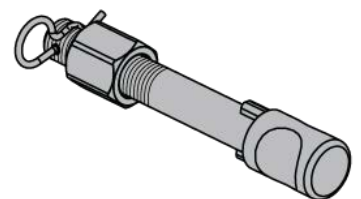

Fig. 5