



Towbar Fitting Instructions
To Suit MAZDA 323 ASTINA HARDTOP 7/94-ON,
323 PROTÉGÉ SEDAN 8/94-ON & FORD LASER 4 DOOR 10/94-ON
Part Number MA55A
Rating 500Kg

NOTE: If fitter is experienced, this product can be fitted without removing the rear bumper bar. The following instructions are aimed at the unexperienced fitter.

NOTE: *Mazda Protégé:* disregard steps 1,2,3,12,13.

1. Ensure all hardware items have been included.
2. Remove rear most interior panel.
3. Remove rear tail lights.
4. Remove rear bumper bar.
5. Remove rear exhaust hanger.
6. Lift towbar into position.
7. Fit two bolts spring washers and nuts through holes that align with shipping hook holes in passenger's side.
8. Ensure towbar is square to vehicle.
9. Using holes in driver's side arm as a guide, drill two 11mm holes through bottom face of chassis rail.
10. Fit tapped plates on wire through large access hole in end of chassis rail and align with holes in towbar. **NOTE:** Access hole may be covered by tape.
11. Fit bolts supplied.
12. Tighten all bolts to torque listing below.
13. Cut and remove small section of bumper as shown in diagram.
14. Refit bumper, lights and accessories.

RECOMMENDED ASSEMBLY TORQUE LISTING

<u>Diameter</u>	<u>Grade 8.8 Bolt</u>
	<u>Nm</u>
M6	9.5
M8	21.7
M10	43.4
M12	77.3
M14	121.0
M16	189.8

Towbar Fitting Instructions
To Suit MAZDA 323 ASTINA HARDTOP 7/94-ON,
323 PROTÉGÉ SEDAN 8/94-ON & FORD LASER 4 DOOR 10/94-ON
Part Number MA55A
Rating 500Kg

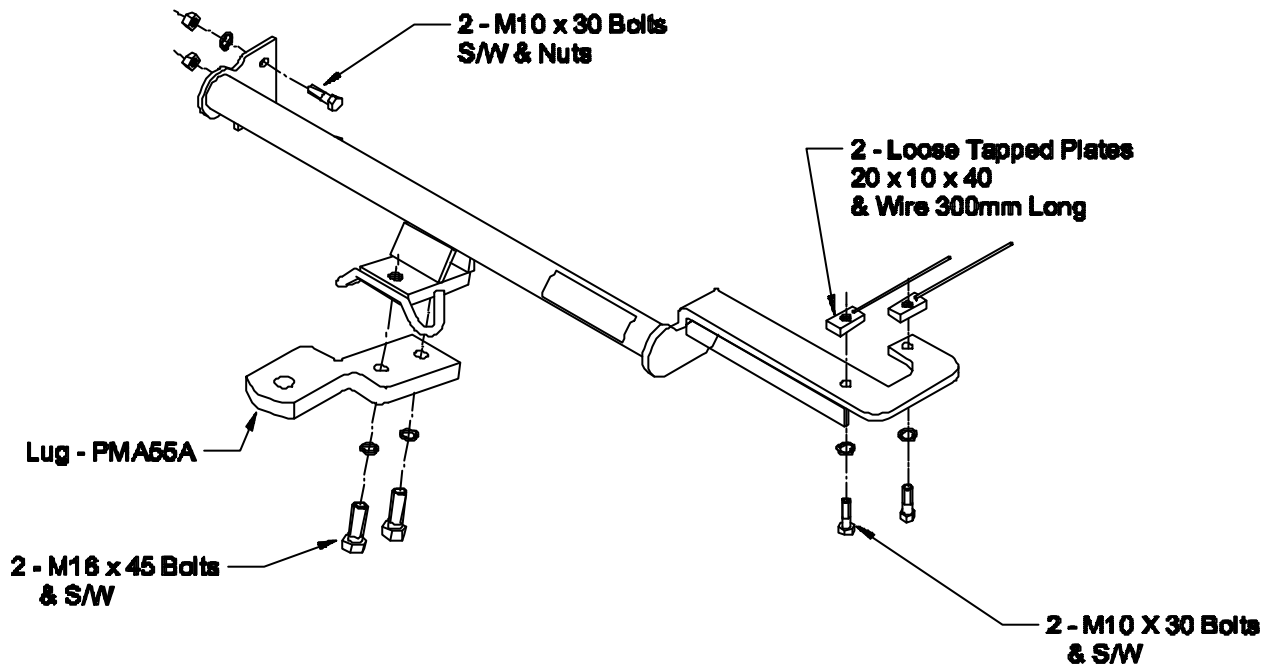

Towbar Fitting Instructions
To Suit MAZDA 323 ASTINA HARDTOP 7/94-ON,
323 PROTÉGÉ SEDAN 8/94-ON & FORD LASER 4 DOOR 10/94-ON
Part Number MA55A
Rating 500Kg

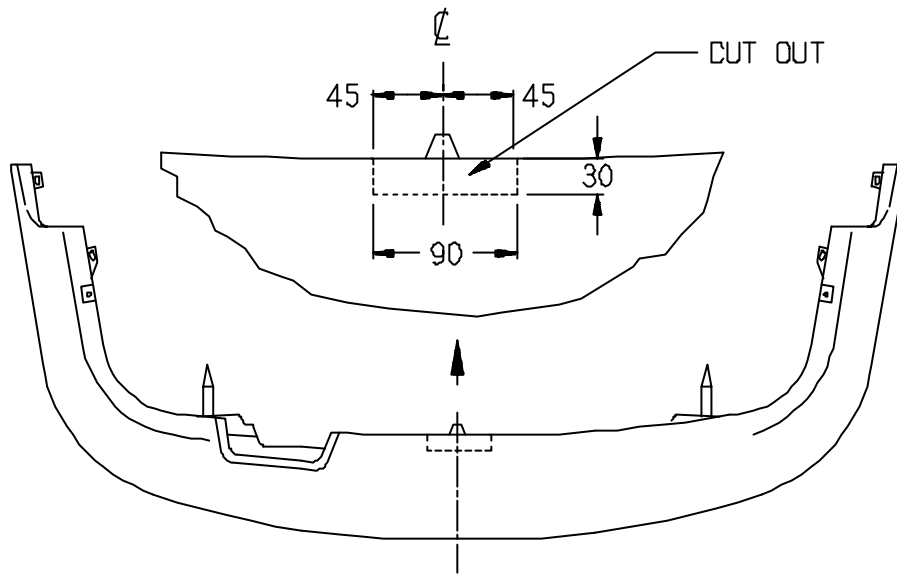

MAZDA 323 - HARD TOP

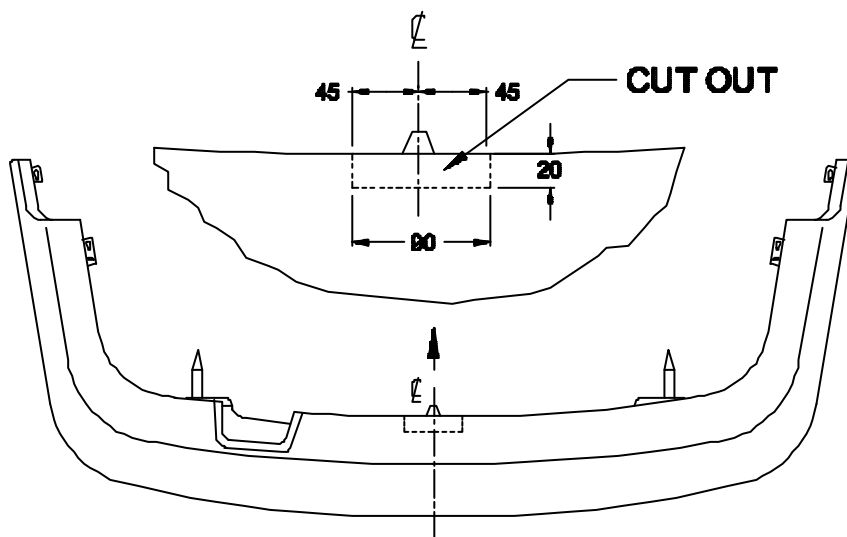

MAZDA 323 - SEDAN