

TRAILBOSS

Towbar Fitting Instructions
To Suit **MERCEDES C CLASS 05/2011 ON**
Part Number **MB26L**
Rating **1250/125 kg**

PLACE THESE INSTRUCTIONS IN THE VEHICLE'S GLOVEBOX AFTER INSTALLATION IS COMPLETE

WARNING:

1. Do not, drill, cut, weld or otherwise modify the tow bar.
2. If you are using electric welding on a motor vehicle, **always** check that the vehicle is not equipped with electronic engine or instrument management equipment. Failure to do so could **destroy** any onboard computers. If in doubt, check with the vehicle's manufacturer.
3. The high tensile fasteners supplied with this product were used to achieve the specified rating. If replacement is required ensure that fasteners of the same rating & quality are used. Contact an authorised **Trailboss** dealer if further information is required.

General:

1. Ensure all hardware items have been included refer to assembly diagram.
2. It is recommended that the instructions are read through and completely understood before making any attempt to fit this product.
3. Be wary of any changes to vehicle designs or other accessories that may conflict with the installation of this product.
4. Before drilling ensure that the area is clear of fuel, electrical & other components.
5. All holes drilled into the body panels shall have all burrs & swarf removed then coated with a suitable rust preventative paint.
6. For vehicles that require the bumper to be cut. Ensure cut out area is in correct position on the vehicle prior to cutting the bumper.
7. The high tensile fasteners supplied with this product were used to achieve the specified rating. If replacement is required ensure that fasteners of the same rating & quality are used. Contact an authorized **Trailboss** dealer if further information is required.
8. Ensure that all hardware is fastened to torque list below check fasteners on regular basis.
9. Tow bar load rating sticker provided with this product shall be conspicuously located on inside rear end of the driver's door. **(See diagram below)**.
10. Trailboss recommends that you check your tow ball to ensure that it complies with the Australian standards **AS 4177.2**.
11. **PLEASE NOTE:** It is advised to remove your lug or tbn when not actually towing so as to produce a clear view of the vehicles registration plate if obscured, and to also provide maximum available departure angle
12. Pull Pin must be fit in down position.

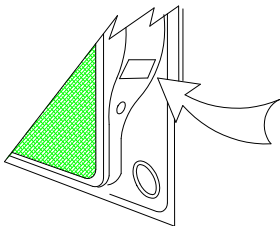

Place load rating sticker
inside driver's door here

FOR TRAILER TOWING PURPOSES ONLY
For towing capacity details please refer to vehicle owner's manual or to the manufacturer. Overloading can void your warranties.

RECOMMENDED ASSEMBLY TORQUE LISTING

Diameter	Grade 8.8 Bolt
M6	9.5 Nm
M8	21.7 Nm
M10	43.4 Nm
M12	77.3Nm
M14	146 Nm
M16	189.8 Nm

Tow bar Maintenance and Care.

Trailboss recommends that bolt torque's, as listed below, are routinely and regularly inspected and checked for correct tension. Replace any worn or defective parts.

We recommended to remove Tow Ball Mounts (TBM's, tongues or lugs) when not being used for any considerable length of time.

So as to avoid injury, when not towing it is suggested that the tongue, Pull Pin and R-clip are removed then stored in a safe, clean and dry place, away from excessive moisture.

Hitch Pull Pins and spring "R" clips are regularly checked for proper installation. Replace any worn or defective parts.



Towbar Fitting Instructions
 To Suit **MERCEDES C CLASS 05/2011 ON**
 Part Number **MB26L**
 Rating **1250/125 kg**

PLACE THESE INSTRUCTIONS IN THE VEHICLE'S GLOVEBOX AFTER INSTALLATION IS COMPLETE

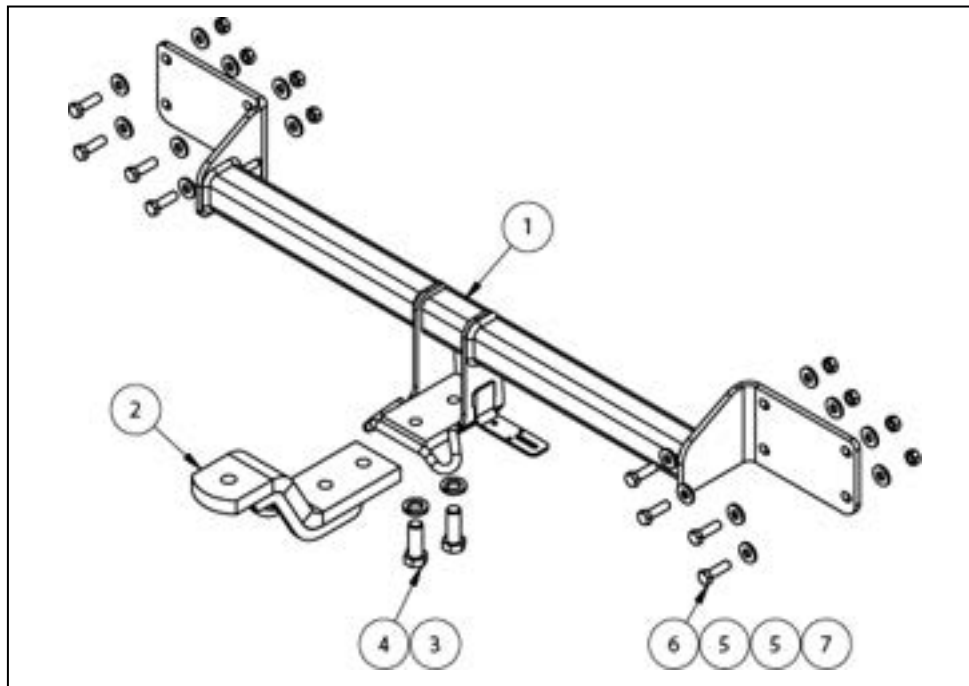



QTY	DESCRIPTION	ITEM NO
1	WELDED ASSEMBLY	1
1	LUG	2
2	M16x5x3.5 SPRING WASHER	3
2	M16x45 2.0P BOLT	4
16	WSHR FT M10x25.4x3	5
8	M10 – 10.5x35mm BOLT	6
8	HEXT NUT M10x1.5	7

ADDITIONAL ITEMS

 WIRING LOOM

 FITTING INSTRUCTION

 LR LABEL

 CP LABEL



Towbar Fitting Instructions
To Suit **MERCEDES C CLASS 05/2011 ON**
Part Number **MB26L**
Rating **1250/125 kg**

PLACE THESE INSTRUCTIONS IN THE VEHICLE'S GLOVEBOX AFTER INSTALLATION IS COMPLETE

INSTRUCTION:

1. Remove 3 Scrivets from Rear Wheel Arc and 1 Plastic Nut for both the LH & RH sides. Also remove 1 Screw from the top edge of the Bumper located behind the Wheel Well Lining.
2. Remove Fasteners as shown from underside of vehicle for both LH & RH side.
3. Remove interior Panels from Boot and Spare tyre and tools from vehicle.
4. Remove 4 Nuts from Rear Lights and unplug them to remove. Firmly pull on Bumper Bar to release from clips, if needed push down on Bumper Clips located under Rear Lights so as to release Bumper.
5. Remove 4 Nuts from Impact Beam for both LH & RH side with 2 located inside Wheel Well and 2 located under vehicle. Discard Impact Beam and all Associated Fasteners.
6. Offer up Towbar to vehicle and fast using the supplied M10 Nuts Bolts and Washers and tighten all to the Torque specifications provided on Page 1.
7. Reassemble vehicle in reverse order to disassembly.



Wiring Loom Fitting Instructions
To Suit Mercedes C Class Sedan / Wagon
Part Number 100515-WL

Wiring Loom Installation Instructions

Mercedes C Class Sedan / Wagon
Part No: 100515-WL

Tail Length Required: 1200mm

ECU Required Part No: 04832

Wiring Loom Installation Time: Approx 30 Mins

Note: Factory RPA cannot be overridden, however it can be disabled through a switch on the vehicle dash.

Wiring Loom Fitting Instructions To Suit Mercedes C Class Sedan / Wagon Part Number 100515-WL

1. In the luggage compartment, remove the floor cover carpet.
2. Remove the rear trim by first removing the two clips.

The following step is for Mercedes C Class Wagon models only.

3. Remove the LHS side access panel cover.

Steps 4-6 are for Mercedes C Class Sedan models only.

4. On the LHS of the luggage compartment, remove the fasteners.
5. Remove the access panel cover.
6. Dislodge the luggage compartment trim.
7. Remove the RHS tail light access panel cover and remove the vehicle first aid kit.
8. On the rear of the luggage compartment, drill a Ø30mm hole in the plastic cover (1).

Note: if occupied, drill a Ø30mm hole next to the plastic cover.

9. File any rough or sharp edges and spray with rust inhibitor.



10. Remove the LHS tail light assembly, by removing the three fasteners.

Repeat for the RHS.

11. In the upper RHS of the luggage compartment, locate the tail light wiring harness.

Wiring Loom Fitting Instructions To Suit Mercedes C Class Sedan / Wagon Part Number 100515-WL

12. Following the table below, connect the ezy-taps (2) to the vehicle tail light wires (3) then connect the trailer harness wire terminals (4) to the ezy taps (2).

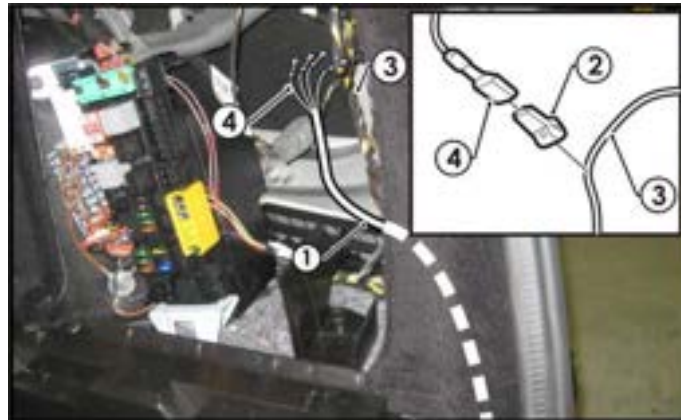

Function	Trailer Patch	Vehicle Connector
R.IND	GREEN / BLACK	BLACK / GREEN
REVERSE	BLACK / WHITE	GREY / YELLOW
TAIL	BROWN / BLACK	BROWN / BLACK
BRAKES	RED / BLACK	BLACK / YELLOW

13. Route the trailer patch harness (P/No: 100515-WL) along the rear of the luggage compartment towards the LHS.
14. Route the trailer patch harness (1) under the LHS side trim and up towards the LHS tail light assembly.
15. Following the table below, connect the ezy-tap (2) to the vehicle L.IND wire (3) then connect the trailer harness 'YELLOW/BLACK' L.IND wire terminal (4) to the ezy-tap (2).

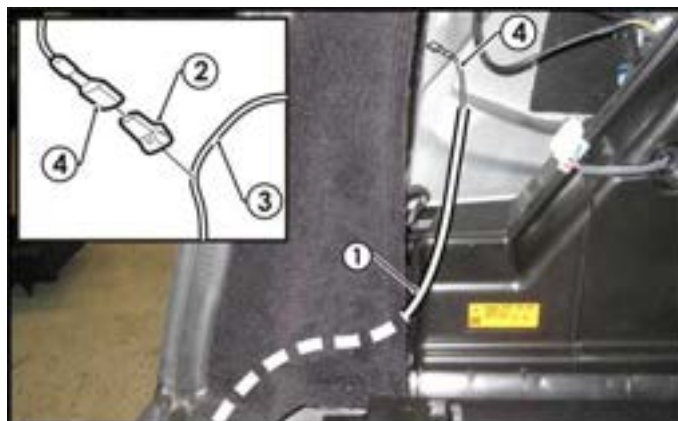

Function	Trailer Patch	Vehicle Connector
L.IND	YELLOW / BLACK	BLACK / WHITE

TRAILBOSS

Wiring Loom Fitting Instructions To Suit Mercedes C Class Sedan / Wagon Part Number 100515-WL

Steps 16-19 are for Mercedes C-Class Wagon models only.

16. Locate the vacant fuse slot (1) (fuse location 36).
17. Insert the supplied 20-amp fuse (2) into the upper slot of the add-a-fuse harness (3).
18. Plug the add-a-fuse harness (3) into the vacant fuse slot (1) on the fuse panel.
19. Connect the 'ORANGE' power wire 1-way connector (4) into the add-a-fuse harness (3) mating connector.

Note: If the fuse location is occupied, first remove the vehicle fuse and insert it in the lower slot of the add-a-fuse harness (3)

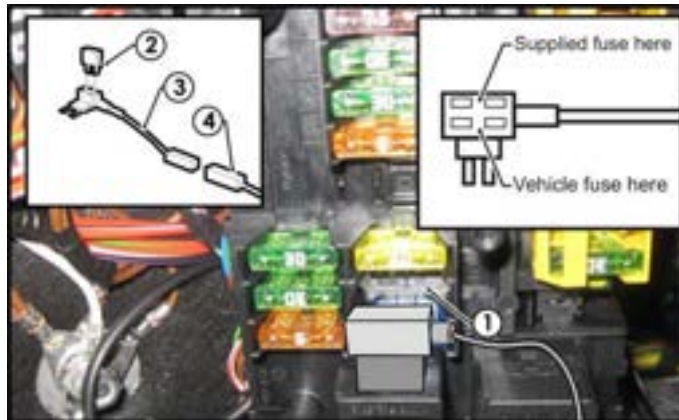

Step 20-23 are for Mercedes C-Class Sedan models only.

20. Locate the vacant fuse slot (1) (fuse location 42).
21. Insert the supplied 25-amp fuse (2) into the upper slot of the add-a-fuse harness (3).
22. Plug the add-a-fuse harness (3) into the vacant fuse slot (1) on the fuse panel in the orientation shown.
23. Connect the 'ORANGE' power wire 1-way connector (4) into the add-a-fuse harness (3) mating connector.

Note: If the fuse location is occupied, first remove the vehicle fuse and insert it in the lower slot of the add-a-fuse harness (3).

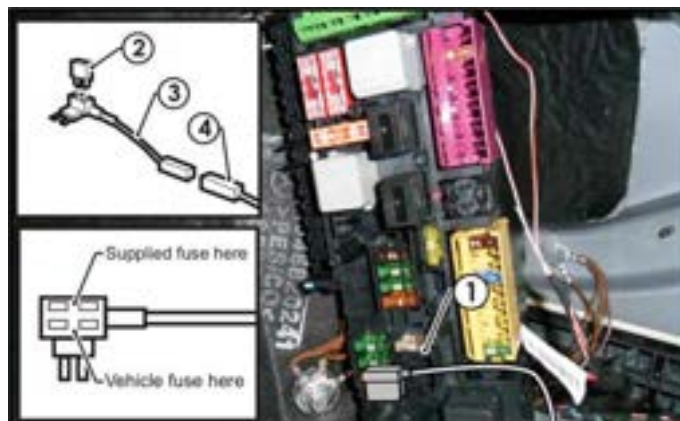



Wiring Loom Fitting Instructions
To Suit Mercedes C Class Sedan / Wagon
Part Number 100515-WL

24. Connect the trailer patch harness ground ring terminal to the vehicle grounding bolt.
25. Connect the trailer harness 12-way connector to the ECU (04832).
26. Apply double sided tape to the ECU and adhere it to the vehicle sheet on the RHS of the luggage compartment.
27. Mount the trailer socket to the towbar mounting bracket using M4 fasteners (not supplied).
28. Route the tail harness across the towbar towards the RHS of the vehicle and up through the previously drilled out hole.
29. Ensure the tail harness grommet is seated correctly and secure in place using a cable tie (not supplied).
30. Connect the tail harness (tail length 1200mm) 8-way connector to the trailer harness mating 8-way connector.
31. Test the trailer harness function using a light board or multimeter.
32. Secure all harnesses using cables ties (not supplied).
33. Re-fit all removed parts and secure all fasteners, ensuring there are no squeaks or rattles.
34. Place instructions in glove box after fitment