

TRAILBOSS

Towbar Fitting Instructions To Suit **MERCEDES B CLASS 03/2012 ON** Part Number **MB27L** Rating **1500/75 kg**

PLACE THESE INSTRUCTIONS IN THE VEHICLE'S GLOVEBOX AFTER INSTALLATION IS COMPLETED

WARNING:

1. Do not, drill, cut, weld or otherwise modify the tow bar.
2. If you are using electric welding on a motor vehicle, **always** check that the vehicle is not equipped with electronic engine or instrument management equipment. Failure to do so could **destroy** any onboard computers. If in doubt, check with the vehicle's manufacturer.
3. The high tensile fasteners supplied with this product were used to achieve the specified rating. If replacement is required ensure that fasteners of the same rating & quality are used. Contact an authorised **Trailboss** dealer if further information is required.

General:

1. Ensure all hardware items have been included refer to assembly diagram.
2. It is recommended that the instructions are read through and completely understood before making any attempt to fit this product.
3. Be wary of any changes to vehicle designs or other accessories that may conflict with the installation of this product.
4. Before drilling ensure that the area is clear of fuel, electrical & other components.
5. All holes drilled into the body panels shall have all burrs & swarf removed then coated with a suitable rust preventative paint.
6. For vehicles that require the bumper to be cut. Ensure cut out area is in correct position on the vehicle prior to cutting the bumper.
7. The high tensile fasteners supplied with this product were used to achieve the specified rating. If replacement is required ensure that fasteners of the same rating & quality are used. Contact an authorized **Trailboss** dealer if further information is required.
8. Ensure that all hardware is fastened to torque list below check fasteners on regular basis.
9. Tow bar load rating sticker provided with this product shall be conspicuously located on inside rear end of the driver's door. **(See diagram below)**.
10. Trailboss recommends that you check your tow ball to ensure that it complies with the Australian standards **AS 4177.2**.
11. **PLEASE NOTE:** It is advised to remove your lug or tbm when not actually towing so as to produce a clear view of the vehicles registration plate if obscured, and to also provide maximum available departure angle
12. Pull Pin must be fit in down position.

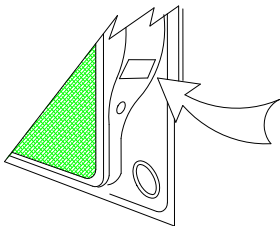

Place load rating sticker
inside driver's door here

FOR TRAILER TOWING PURPOSES ONLY
For towing capacity details please refer to vehicle owner's manual or to the manufacturer. Overloading can void your warranties.

RECOMMENDED ASSEMBLY TORQUE LISTING

<u>Diameter</u>	<u>Grade 8.8 Bolt</u>
M6	9.5 Nm
M8	21.7 Nm
M10	43.4 Nm
M12	77.3Nm
M14	146 Nm
M16	189.8 Nm

Tow bar Maintenance and Care.

Trailboss recommends that bolt torque's, as listed below, are routinely and regularly inspected and checked for correct tension. Replace any worn or defective parts.

We recommended to remove Tow Ball Mounts (TBM's, tongues or lugs) when not being used for any considerable length of time.

So as to avoid injury, when not towing it is suggested that the tongue, Pull Pin and R-clip are removed then stored in a safe, clean and dry place, away from excessive moisture.

Hitch Pull Pins and spring "R" clips are regularly checked for proper installation. Replace any worn or defective parts.

TRAILBOSS

Towbar Fitting Instructions
 To Suit **MERCEDES B CLASS 03/2012 ON**
 Part Number **MB27L**
 Rating **1500/75 kg**

PLACE THESE INSTRUCTIONS IN THE VEHICLE'S GLOVEBOX AFTER INSTALLATION IS COMPLETED

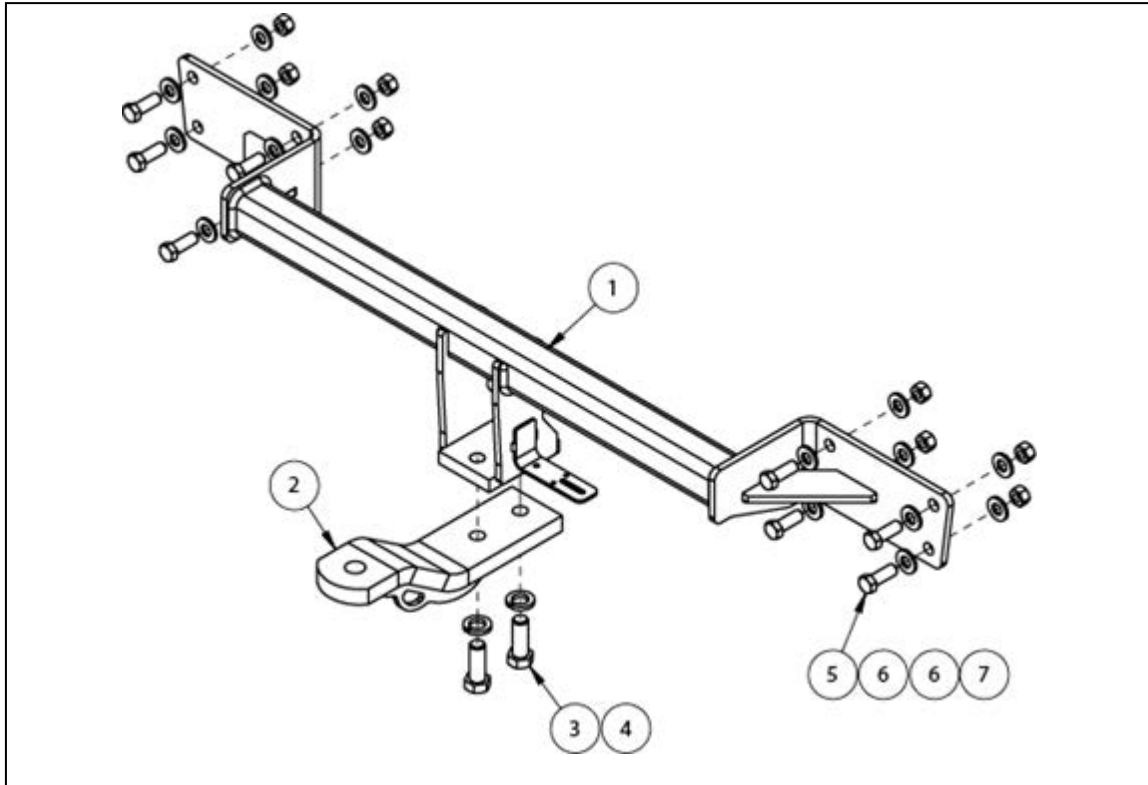

QTY	DESCRIPTION	ITEM NO.
1	WELDED TOWBAR	1
1	LUG	2
2	M16x45 2.0P BOLT	3
2	M16x5x3.5 SPRING WASHER	4
8	M12x35 1.75P BOLT	5
16	WASHER FLAT 1/2"x1/8"x1/8"	6
8	M12x1.75 HEX NUT PC8	7

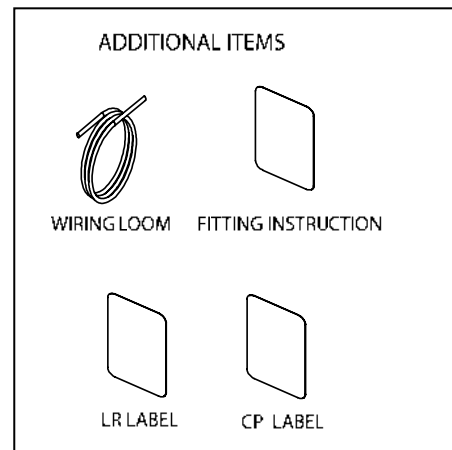



Towbar Fitting Instructions
To Suit **MERCEDES B CLASS 03/2012 ON**
Part Number **MB27L**
Rating **1500/75 kg**

PLACE THESE INSTRUCTIONS IN THE VEHICLE'S GLOVEBOX AFTER INSTALLATION IS COMPLETED

INSTRUCTION:

1. Open Boot and remove Boot Side Trim from the LHS. Remove 3 Nuts and Wiring Connector and dislodge the Tail Light assembly. Repeat for RHS.
2. Remove 1 Scrivet from Inside of Rear Wheel Arch and underneath Bumper on both sides of vehicle.
3. Force Wheel Arch Trim away Bumper to expose 2 Nuts fastening the Bumper to rear Quarter Panel .Remove the 2 Screws on the LHS side of Bumper .Repeat for RHS.
4. Carefully remove Bumper and disconnect any wiring Harness Connectors fitted.
5. Remove Nuts on Exhaust Heat Shield and loosen to get better access to Rear Impact Beam Bolts.
6. Remove 4 Bolts on LHS Rear Chassis Panel fastening Impact Beam to Chassis. Repeat for RHS. Remove and discard Impact Beam and fasteners.
7. Offer Towbar to Vehicle and fasten using M12 Bolts ,Washers and Nuts as shown on Page 2.Fasten all Bolts to Torque specification on page1.
8. Reattach Bumper using 1-6 in reverse.

TRAILBOSS

Towbar Fitting Instructions
To Suit **MERCEDES B CLASS HATCH 03/2012 –ON**
Part Number **MB27L**
Rating **1500/75 kg**

PLACE THESE INSTRUCTIONS IN THE VEHICLE'S GLOVEBOX AFTER INSTALLATION IS COMPLETE

WARNING:

1. Do not, drill, cut, weld or otherwise modify the tow bar.
2. If you are using electric welding on a motor vehicle, **always** check that the vehicle is not equipped with electronic engine or instrument management equipment. Failure to do so could **destroy** any onboard computers. If in doubt, check with the vehicle's manufacturer.
3. The high tensile fasteners supplied with this product were used to achieve the specified rating. If replacement is required ensure that fasteners of the same rating & quality are used. Contact an authorised **Trailboss** dealer if further information is required.

General:

1. Ensure all hardware items have been included refer to assembly diagram.
2. It is recommended that the instructions are read through and completely understood before making any attempt to fit this product.
3. Be wary of any changes to vehicle designs or other accessories that may conflict with the installation of this product.
4. Before drilling ensure that the area is clear of fuel, electrical & other components.
5. All holes drilled into the body panels shall have all burrs & swarf removed then coated with a suitable rust preventative paint.
6. For vehicles that require the bumper to be cut. Ensure cut out area is in correct position on the vehicle prior to cutting the bumper.
7. The high tensile fasteners supplied with this product were used to achieve the specified rating. If replacement is required ensure that fasteners of the same rating & quality are used. Contact an authorized **Trailboss** dealer if further information is required.
8. Ensure that all hardware is fastened to torque list below check fasteners on regular basis.
9. Tow bar load rating sticker provided with this product shall be conspicuously located on inside rear end of the driver's door. **(See diagram below)**.
10. Trailboss recommends that you check your tow ball to ensure that it complies with the Australian standards **AS 4177.2**.
11. **PLEASE NOTE:** It is advised to remove your lug or tbm when not actually towing so as to produce a clear view of the vehicles registration plate if obscured, and to also provide maximum available departure angle
12. Pull Pin must be fit in down position.

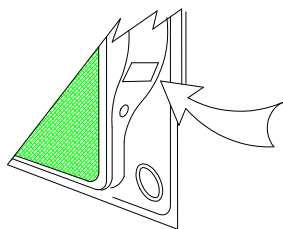

Place load rating sticker
inside driver's door here

FOR TRAILER TOWING PURPOSES ONLY
For towing capacity details please refer to vehicle owner's manual or to the manufacturer. Overloading can void your warranties.

RECOMMENDED ASSEMBLY TORQUE LISTING

Diameter	Grade 8.8 Bolt
M6	9.5 Nm
M8	21.7 Nm
M10	43.4 Nm
M12	77.3Nm
M14	146 Nm
M16	189.8 Nm

Tow bar Maintenance and Care.

Trailboss recommends that bolt torque's, as listed below, are routinely and regularly inspected and checked for correct tension. Replace any worn or defective parts.

We recommended to remove Tow Ball Mounts (TBM's, tongues or lugs) when not being used for any considerable length of time.

So as to avoid injury, when not towing it is suggested that the tongue, Pull Pin and R-clip are removed then stored in a safe, clean and dry place, away from excessive moisture.

Hitch Pull Pins and spring "R" clips are regularly checked for proper installation. Replace any worn or defective parts.

TRAILBOSS

Towbar Fitting Instructions
 To Suit **MERCEDES B CLASS HATCH 03/2012 –ON**
 Part Number **MB27L**
 Rating **1500/75 kg**

PLACE THESE INSTRUCTIONS IN THE VEHICLE'S GLOVEBOX AFTER INSTALLATION IS COMPLETE

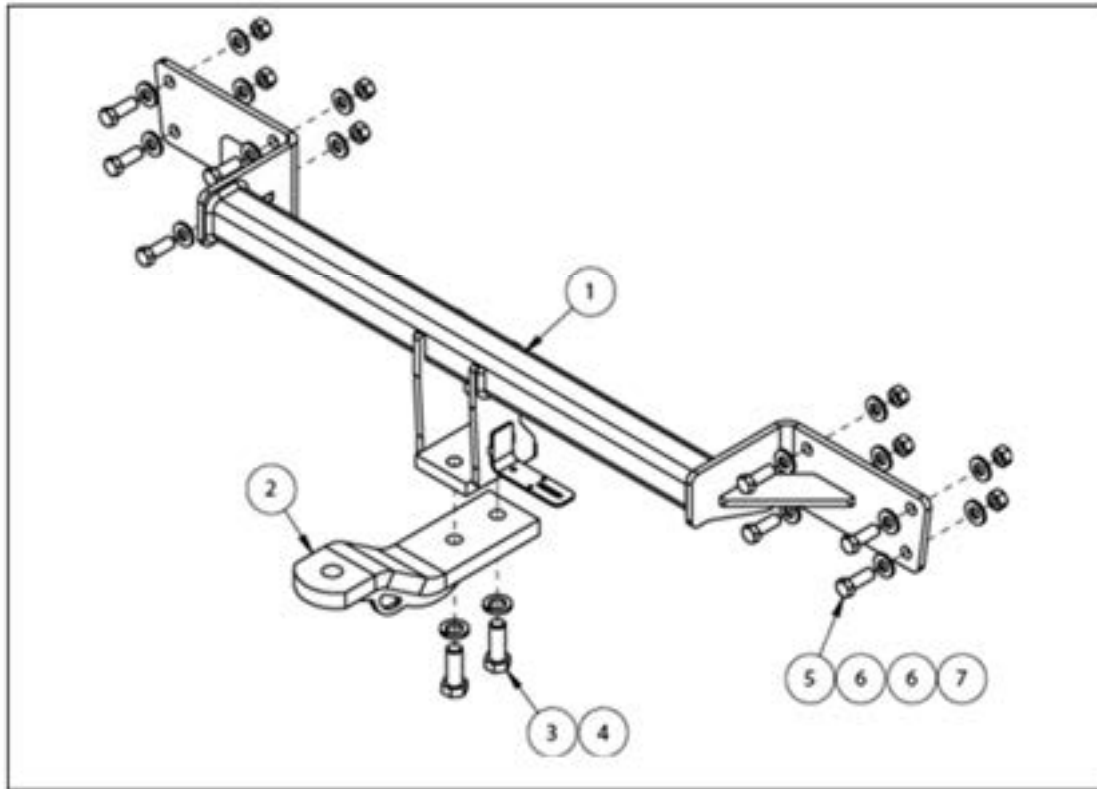

QTY	DESCRIPTION	ITEM NO.
1	WELDED TOWBAR	1
1	LUG	2
2	M16x45 2.0P BOLT	3
2	M16x5x3.5 SPRING WASHER	4
8	M12x35 1.75P BOLT	5
16	WASHER FLAT 1/2"x1/8"x1/8"	6
8	M12x1.75 HEX NUT PC8	7

ADDITIONAL ITEMS



WIRING LOOM



FITTING INSTRUCTION



LR LABEL



CP LABEL



Towbar Fitting Instructions
To Suit **MERCEDES B CLASS HATCH 03/2012 –ON**
Part Number **MB27L**
Rating **1500/75 kg**

PLACE THESE INSTRUCTIONS IN THE VEHICLE'S GLOVEBOX AFTER INSTALLATION IS COMPLETE

INSTRUCTION:

1. Open Boot and remove Boot Side Trim from the LHS. Remove 3 Nuts and Wiring Connector and dislodge the Tail Light assembly. Repeat for RHS.
2. Remove 1 Scrivet from Inside of Rear Wheel Arch and underneath Bumper on both sides of vehicle.
3. Force Wheel Arch Trim away Bumper to expose 2 Nuts fastening the Bumper to rear Quarter Panel .Remove the 2 Screws on the LHS side of Bumper .Repeat for RHS.
4. Carefully remove Bumper and disconnect any wiring Harness Connectors fitted.
5. Remove Nuts on Exhaust Heat Shield and loosen to get better access to Rear Impact Beam Bolts.
6. Remove 4 Bolts on LHS Rear Chassis Panel fastening Impact Beam to Chassis. Repeat for RHS. Remove and discard Impact Beam and fasteners.
7. Offer Towbar to Vehicle and fasten using M12 Bolts ,Washers and Nuts as shown on Page 2.Fasten all Bolts to Torque specification on page1.
8. Reattach Bumper using 1-6 in reverse.



Wiring Loom Fitting Instructions
To Suit Mercedes B-Class
Part Number 100869-WL

Wiring Loom Installation Instructions

Mercedes B-Class
Part No: 100869-WL
ECU Required: 04831

Tail Harness Length Required: 1200mm

Wiring Loom Installation Time: Approx 20 Mins

Wiring Loom Fitting Instructions To Suit Mercedes B-Class Part Number 100869-WL

1. In the luggage compartment, remove the rubber floor cover.
2. Remove the six star screws underneath the plastic trim cover and dislodge.
3. Dislodge both the LHS & RHS luggage compartment trims by removing the four fasteners, the two cargo hooks and the two access panels.
4. On the LHS rear quarter panel, following the table below, connect the ezy-taps (1) to the corresponding vehicle wires (2), then connect the trailer patch terminals (3) to the ezy-taps (1).

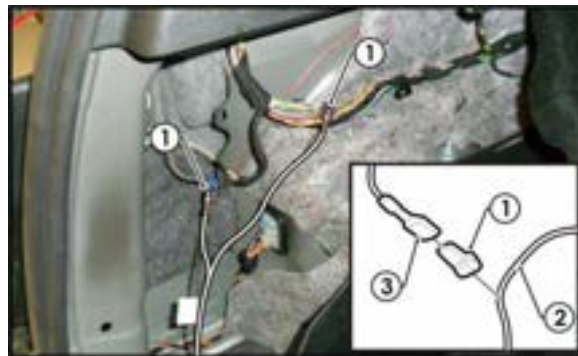

Function	Trailer Patch	Vehicle Connector
L IND	YELLOW / BLACK	BLACK / YELLOW
REV	BLACK / WHITE	GREY / YELLOW

5. Route the trailer harness (100869-WL) along the rear luggage compartment towards the RHS.
6. On the RHS rear quarter panel, connect the trailer patch ground ring terminal (1) to the vehicle grounding point (2).
7. Following the table below, connect the ezy-tap (3) 'ORANGE' power wire to the vehicle 'YELLOW / RED' +12V wire (4), then connect the trailer patch terminal (5) to the ezy-tap (3).

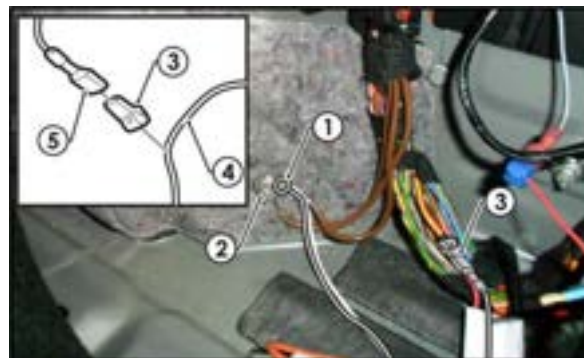

Function	Trailer Patch	Vehicle Connector
+12V	ORANGE	YELLOW / RED

Wiring Loom Fitting Instructions To Suit Mercedes B-Class Part Number 100869-WL

8. On the RHS rear quarter of the vehicle, drill a Ø30mm hole (1).



9. File any rough or sharp edges and spray on rust inhibitor.
10. In the RHS of luggage compartment, following the table below, connect the ezy-taps to the corresponding tail light wires, then connect the trailer patch terminals to the ezy-taps.

Function	Trailer Patch	Vehicle Connector
R.IND	GREEN / BLACK	GREEN / BLACK
BRAKES	RED / BLACK	GREY / RED
TAIL	BROWN / BLACK	GREY / ORANGE

11. Apply double sided tape to the ECU (04831) and adhere it to the vehicle sheet metal on the RHS of the luggage compartment, in a suitable location.
12. Connect the trailer patch 12-way connector to the ECU.
13. Mount the trailer socket to the tow bar mounting bracket using M4 fasteners (not supplied).
14. Route the tail harness across the tow bar towards the RHS of the vehicle and up through the previously drilled out hole.
15. Ensure the tail harness grommet is seated correctly and secure in place using a cable tie (not supplied).
16. Connect the tail harness (tail length 1200mm) 8-way connector to the trailer patch mating 8-way connector.
17. Test the trailer patch function using a light board or multi meter.
18. Secure all harnesses using cable ties (not supplied).
19. Re-fit all removed parts and secure all fasteners, ensuring there are no squeaks or rattles.
20. Place the fitting instructions in the glove box after fitment.