



Towbar Fitting Instructions
To Suit TOYOTA KLUGER 11/03-on
Part Number QT1104
Rating 1500Kg

WARNING :

1. Do not, drill, cut, weld or otherwise modify the towbar.
2. If you are using electric welding on a motor vehicle, always check that the vehicle is not equipped with electronic engine or instrument management equipment. Failure to do so could destroy any onboard computers. If in doubt, check with the vehicle's manufacturer.

Max. Towing Weight: 1500

1. Ensure all hardware items have been included.
2. Remove 2x plastic trim buttons from spare wheel tool compartment and remove tray.
3. Undo 4x 10mm nuts from back side of bumper in tool compartment cavity.
4. Undo 2x screws from top centre of bumper bar.
5. Undo 4x screws from either side, bottom corner of bumper bar and 2x plastic trim buttons.
6. Remove mud guards via 8x Socket Head Cap (Allen key) screws and remove bumper bar.
7. Remove foam bolster and impact beam via 6x12mm nuts.
8. Fit towbar and tighten 4x M10 bolts to specified torque.
9. Fit and tighten 6x M8 nuts to specified torque.
10. Refit foam bolster and cut-out to clear towbar.
11. Mark and cut bumper.
12. Refit bumper, mud guards and tool compartment.

RECOMMENDED ASSEMBLY TORQUE LISTING

Diameter Grade 8.8 Bolt

	Nm
M6	9.5
M8	21.7
M10	43.4
M12	77.3
M16	189.8

TRAILBOSS

Towbar Fitting Instructions
To Suit TOYOTA KLUGER 11/03-on
Part Number QT1104
Rating 1500Kg

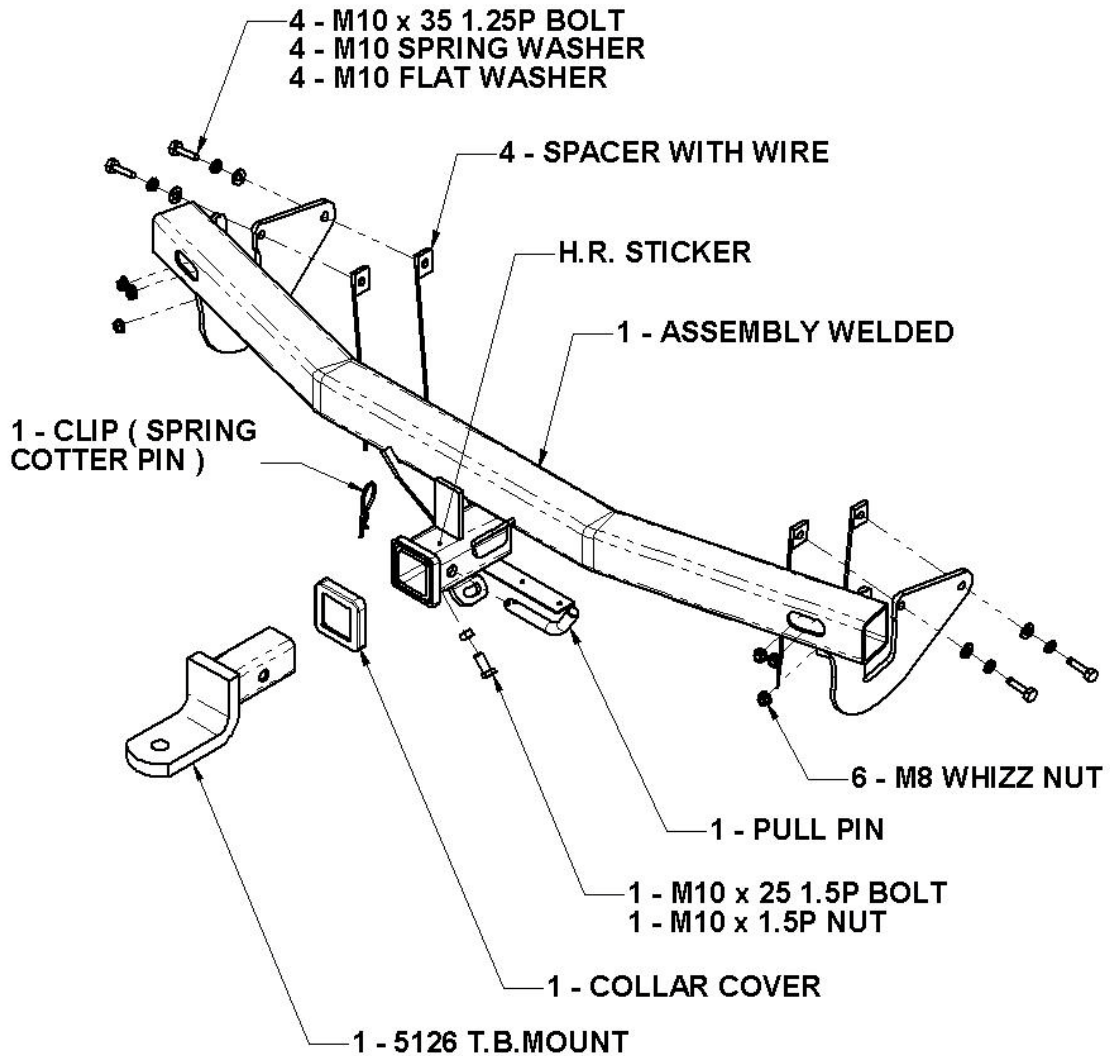

Cut out bumper as shown

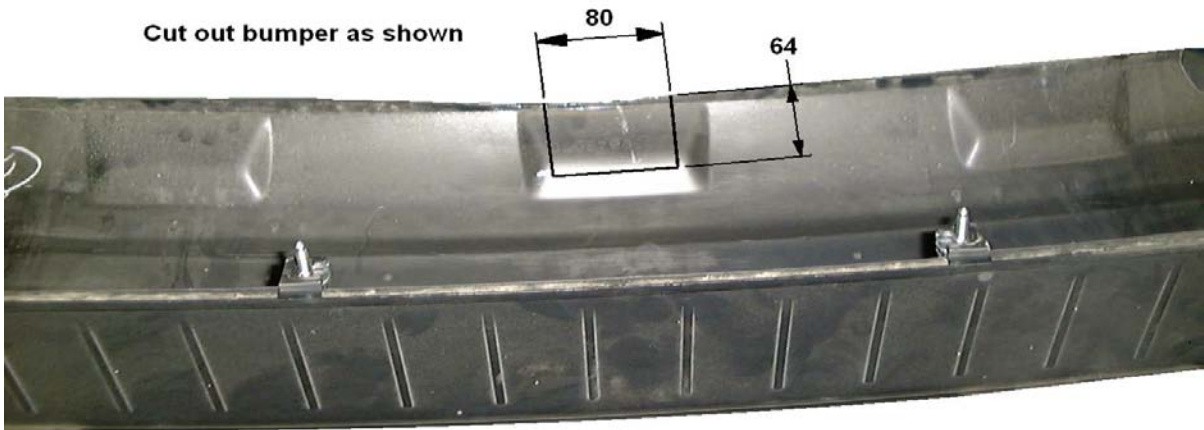

Bumper Cut