

# TRAILBOSS

Towbar Fitting Instructions  
To Suit TOYOTA RAV 4 AWD 5 DOOR WAGON 02-2006-on  
Part Number QT1107L  
Rating 4 Cylinder 2/06-on 1500-150 kg 6 Cylinder 10/07-on 1900-190 Kg

**WARNING:**

1. Do not, drill, cut, weld or otherwise modify the tow bar.
2. If you are using electric welding on a motor vehicle, **always** check that the vehicle is not equipped with electronic engine or instrument management equipment. Failure to do so could **destroy** any onboard computers. If in doubt, check with the vehicle's manufacturer.



**CAUTION TWO PEOPLE ARE REQUIRED TO FIT THIS PRODUCT.**

1. Ensure all hardware items have been included.
2. Remove shipping hook from passenger side then discard.
3. Remove 2 plastic trim buttons from underside of rear bumper, then let bumper tags hang freely.
4. Carefully flex rear bumper bar skin out from the underside of vehicle, and then offer tow bar to the chassis sub frame so that the slots in the side plates of the tow bar align with the captive nuts in the chassis sub frame.
5. Fasten all hardware loosely as per diagram below then tighten all hardware to torque listing.
6. Refit 2 plastic trim buttons to underside of bumper bar skin.

**NOTE:** Trailboss recommends that you check your towball to ensure it complies with the Australian standard AS 4177.2

**RECOMMENDED ASSEMBLY TORQUE LISTING**

**Diameter Grade 8.8 Bolt**

	Nm;
M6	9.5
M8	21.7
M10	43.4
M12	77.3
M16	189.8

**FOR TOWING PURPOSES ONLY**  
For towing capacity details please refer to vehicle owner's manual or to the manufacturer. Overloading can void your warranties.

**PLEASE NOTE:** It is advised to remove lug from receiver box when not actually towing so as to produce a clear view of the vehicles registration plate if obscured, and to also provide increased departure angle.

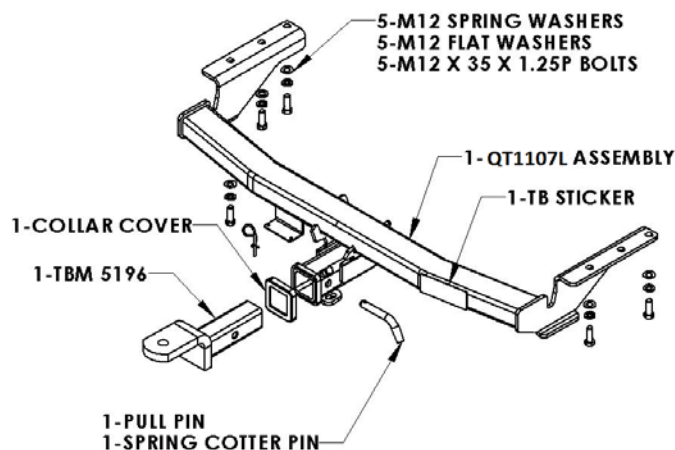



Wiring Loom Fitting Instructions  
To Suit Toyota 664L Rav4  
Part Number 100098-WL

## Wiring Loom Installation Instructions

Toyota 664L Rav4  
Part No: 100098-WL

Tail Length Required: 1800mm

ECU Required Part No: 04826  
RPA Override Switch Part No: 04848 (If Fitted)

Wiring Loom Installation Time: Approx 30 Mins

## Wiring Loom Fitting Instructions To Suit Toyota 664L Rav4 Part Number 100098-WL

1. In the luggage compartment, remove the two carpet covers.
2. Remove the storage tray, by first removing the four fasteners.
3. Remove the LHS access panel cover.
4. Dislodge the LHS side trim by first removing the cargo tie down hooks.
5. Disconnect the LHS 12v accessory connector and then remove the LHS side trim.
6. Remove the LHS vehicle grommet (1).

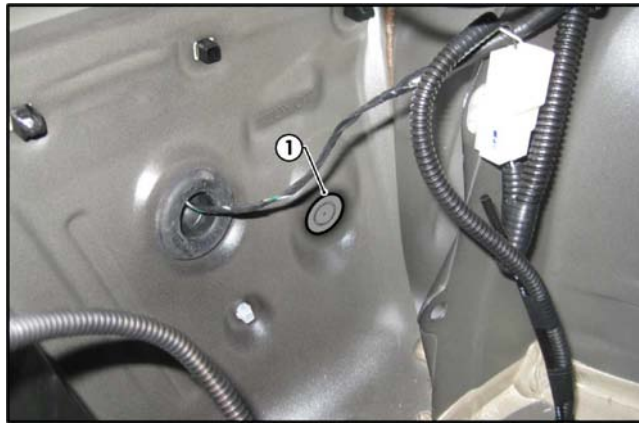

7. Drill out the grommet hole to Ø31mm.
8. File any rough or sharp edges and spray on rust inhibitor.
9. Remove the rear trim.
10. Remove the RHS access panel cover.
11. Locate the RHS tail light connector.
12. Patch in the trailer patch harness (P/No: 100098) mating connectors.
13. Route the trailer patch harness across the rear of the luggage compartment and towards the LHS.
14. Locate the LHS tail light connector.
15. Patch in the trailer patch harness mating connectors.
16. Using a tech screw, secure the trailer patch harness ground ring terminal to the LHS silver bracket.
17. Connect the trailer harness 12-way connector to the ECU (04826).
18. Apply double sided tape to the ECU and adhere it to the vehicle sheet metal on the

# TRAILBOSS

## Wiring Loom Fitting Instructions To Suit Toyota 664L Rav4 Part Number 100098-WL

LHS wheel arch of the luggage compartment.

19. Route the trailer harness 'ORANGE' power wire along the LHS of the vehicle and up towards the fuse panel located underneath the dashboard.
20. Locate the vacant fuse slot (1).

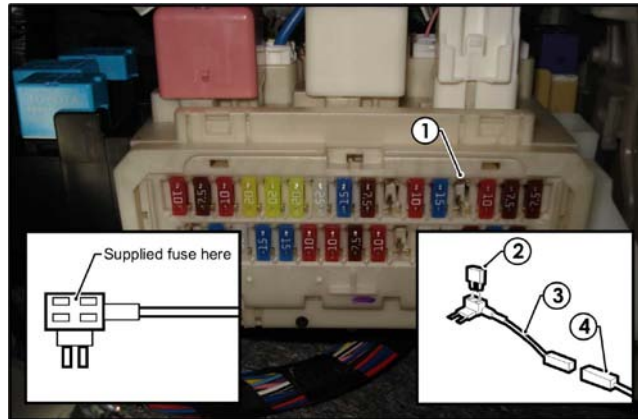

21. Insert the supplied 20-amp fuse (2) into the upper slot of the add-a-fuse harness (3).
22. Plug the add-a-fuse harness into the vacant fuse slot (1) on the fuse panel.
23. Connect the 'ORANGE' power wire 1-way connector (4) into the add-a-fuse harness mating connector.

**Note: If the fuse location is occupied, first remove the vehicle fuse and insert it into the lower slot of the add-a-fuse harness.**

24. Mount the trailer socket to the towbar mounting bracket using M4 fasteners (not supplied).
25. Route the tail harness across the towbar, towards the LHS of the vehicle and up through the previously drilled out hole.
26. Ensure the tail harness grommet is seated correctly and secure in place using a cable tie (not supplied).
27. Connect the tail harness (tail length 1800mm) 8-way connector to the trailer harness mating 8-way connector.
28. Test the Trailer socket using a light board or multi-meter.
29. Secure all harnesses using cables ties (not supplied).
30. Re-fit all removed parts and secure all fasteners, ensuring there are no squeaks or rattles.
31. Place the instructions in the glove box after fitment.