

# TRAILBOSS

## Towbar Fitting Instructions To Suit **FIAT FREEMONT / DODGE JOURNEY 2008 ON** Part Number **QT1125L** Rating **1600/160 kg**

PLACE THESE INSTRUCTIONS IN THE VEHICLE'S GLOVEBOX AFTER INSTALLATION IS COMPLETED

### **WARNING:**

1. Do not, drill, cut, weld or otherwise modify the tow bar.
2. If you are using electric welding on a motor vehicle, **always** check that the vehicle is not equipped with electronic engine or instrument management equipment. Failure to do so could **destroy** any onboard computers. If in doubt, check with the vehicle's manufacturer.
3. The high tensile fasteners supplied with this product were used to achieve the specified rating. If replacement is required ensure that fasteners of the same rating & quality are used. Contact an authorised **Trailboss** dealer if further information is required.
4. If TBM is used in inverted position tow ball may make contact with rear tailgate when lowered, which could cause damage.

### **General:**

1. Ensure all hardware items have been included refer to assembly diagram.
2. It is recommended that the instructions are read through and completely understood before making any attempt to fit this product.
3. Be wary of any changes to vehicle designs or other accessories that may conflict with the installation of this product.
4. Before drilling ensure that the area is clear of fuel, electrical & other components.
5. All holes drilled into the body panels shall have all burrs & swarf removed then coated with a suitable rust preventative paint.
6. For vehicles that require the bumper to be cut. Ensure cut out area is in correct position on the vehicle prior to cutting the bumper.
7. The high tensile fasteners supplied with this product were used to achieve the specified rating. If replacement is required ensure that fasteners of the same rating & quality are used. Contact an authorized **Trailboss** dealer if further information is required.
8. Ensure that all hardware is fastened to torque list below check fasteners on regular basis.
9. Tow bar load rating sticker provided with this product shall be conspicuously located on inside rear end of the driver's door. **(See diagram below).**
10. Trailboss recommends that you check your tow ball to ensure that it complies with the Australian standards **AS 4177.2.**
11. **PLEASE NOTE:** It is advised to remove your lug or tbn when not actually towing so as to produce a clear view of the vehicles registration plate if obscured, and to also provide maximum available departure angle
12. Pull Pin must be fit in down position.

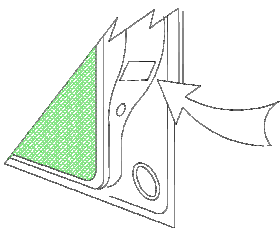

Place load rating sticker  
inside driver's door here

**FOR TRAILER TOWING PURPOSES ONLY**  
For towing capacity details please refer to vehicle owner's manual or to the manufacturer. Overloading can void your warranties.

### **RECOMMENDED ASSEMBLY TORQUE LISTING**

<u>Diameter</u>	<u>Grade 8.8 Bolt</u>
M6	9.5 Nm
M8	21.7 Nm
M10	43.4 Nm
M12	77.3Nm
M14	146 Nm
M16	189.8 Nm

### **Tow bar Maintenance and Care.**

Trailboss recommends that bolt torque's, as listed below, are routinely and regularly inspected and checked for correct tension. Replace any worn or defective parts.

We recommended to remove Tow Ball Mounts (TBM's, tongues or lugs) when not being used for any considerable length of time.

So as to avoid injury, when not towing it is suggested that the tongue, Pull Pin and R-clip are removed then stored in a safe, clean and dry place, away from excessive moisture.

Hitch Pull Pins and spring "R" clips are regularly checked for proper installation. Replace any worn or defective parts.

# TRAILBOSS

Towbar Fitting Instructions  
 To Suit **FIAT FREEMONT / DODGE JOURNEY 2008 ON**  
 Part Number **QT1125L**  
 Rating **1600/160 kg**

PLACE THESE INSTRUCTIONS IN THE VEHICLE'S GLOVEBOX AFTER INSTALLATION IS COMPLETED

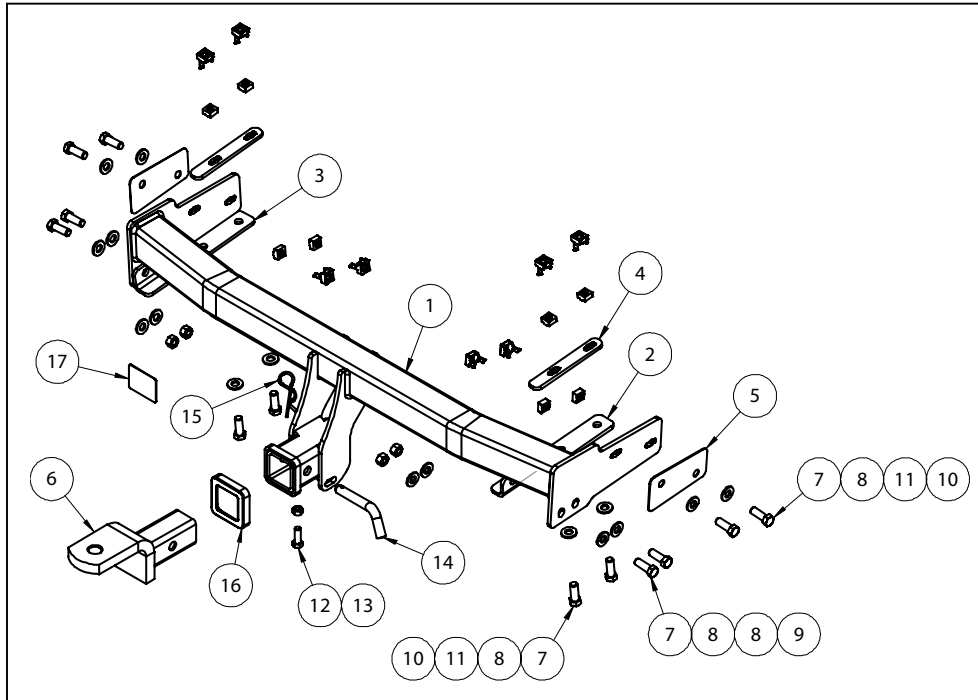

QTY	DESCRIPTION	ITEM NO
1	WELDED ASSEMBLY	1
1	CHASSIS RAIL BRACKET-RHS	2
1	CHASSIS RAIL BRACKET-LHS	3
2	CHASSIS RAIL PLATE	4
2	WASHER PLATE	5
1	TBM ASSEMBLY	6
12	SET SCREW M12x35 1.75P	7
16	WASHER FLAT 1/2"x1 1/8"x1/8"	8
4	HEX NUT M12x1.75	9
8	CAGE NUT RETAINER	10
8	M12x1.75P CAGE NUT	11
1	SET SCREW HEX HD M10x30x1.5P	12
1	HEX NUT M10x1.5	13
1	PULL PIN	14
1	R CLIP	15
1	HITCH BOX COLLAR COVER	16
1	ACRYLIC COMPLIANCE PLATE	17

ADDITIONAL ITEMS



WIRING LOOM



FITTING INSTRUCTION



LR LABEL

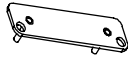

PLUG BRACKET

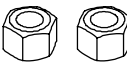

NUT NYLOC



Towbar Fitting Instructions  
To Suit **FIAT FREEMONT / DODGE JOURNEY 2008 ON**  
Part Number **QT1125L**  
Rating **1600/160 kg**

PLACE THESE INSTRUCTIONS IN THE VEHICLE'S GLOVEBOX AFTER INSTALLATION IS COMPLETED

**INSTRUCTION:**

1. Remove 3 off pop rivets and 1 off push rivets from bumper trim in rear wheel arch. Repeat for opposing side of the vehicle.
2. Remove 1 off Screw from bumper trim in rear wheel arch. Repeat for opposing side of the vehicle.
3. Remove 4 off push rivets and 4 off pop rivets above bumper step.  
Disconnect any wiring to bumper skin before removal of bumper skin.
4. Remove 2 off Xmas Tree Clips mounting electric cable to impact beam.  
Remove 6 Nuts holding impact beam, remove and discard Impact beam.
5. Disconnect 3 off Rubber mounts near muffler and lower muffler.
6. Install Cage Nuts onto side arms in the 4 profiled holes.
7. Place Towbar inside chassis rails. Loosely secure Towbar to side of chassis rail with two M12 x 35 Set Screws, one Washer plate and two Flat Washers provided on both sides. Repeat for opposite side of the vehicle.
8. Install Cage Nuts onto 2 off chassis rail plates in the profiled holes.
9. Slide chassis rail plates into chassis rail and loosely secure chassis rail bracket to underside of chassis rail with two M12 x 35 Set Screws and two Flat Washers. Repeat for opposite side of the vehicle.
10. Loosely bolt together side arm to chassis rail bracket with two M12 x 35 Set Screws and four Flat Washers and two M12 Nuts. Repeat for opposite side of vehicle  
Finger tighten chassis rail Set Screws, followed by tightening the chassis rail set screws to the specified torque.
11. Establish centre point of the bumper skin; cut 95 x 95mm section for the bottom edge of the bumper skin.
12. Trim polystyrene back by 10mm, or as required to provide clearance to Towbar cross tube.  
Refit bumper skin by following steps 1-5 in reverse order.



Wiring Loom Fitting Instructions  
To Suit Dodge Journey / Fiat Freemont / VW Transporter / Caravelle / Jeep Patriot /  
Compass / Multivan / Ford F250 / Foton Aumark / Fuso Rosa / Jeep Grand Cherokee  
Part Number 100148-WL

## Wiring Loom Installation Instructions

Dodge Journey / Fiat Freemont / VW Transporter / Caravelle /  
Jeep Patriot / Compass / Multivan / Ford F250 / Foton Aumark /  
Fusa Rosa / Jeep Grand Cherokee  
Part No: 100148-WL

Dodge Journey / Fiat Freemont Tail Harness Length Required: 1800mm  
VW Transporter / Caravelle / Multivan Tail Harnesses Length Required: 1200mm  
Jeep Patriot / Compass Tail Harness Length Required: 1800mm  
Ford F250 Tail Length Required: 1200mm  
Foton Aumark Tail Length Required: 1200mm  
Fuso Rosa Tail Length Required: 1200mm  
Jeep Grand Cherokee Tail Length: 1200mm

Dodge Journey / Fiat Freemont – Page 2 - 3  
VW Transporter / Caravelle / Multivan – Page 4- 5  
Jeep Patriot / Compass – Page 6-7  
Ford F250 – Page 8  
Foton Aumark – Page 9-10  
Fuso Rosa – Page 11  
Jeep Grand Cherokee – Page 12

Wiring Loom Installation Time: Approx. 45 Mins

- **For Volkswagen/Fiat Freemont vehicles only, if vehicle utilizes LED trailer lights and/or exceeds 5Amps, ensure to use harness 04916.**
- **If Jeep Cherokee used with brake controller, 04916 is required.**



**Wiring Loom Fitting Instructions**  
**To Suit Dodge Journey / Fiat Freemont / VW Transporter / Caravelle / Jeep Patriot /**  
**Compass / Multivan / Ford F250 / Foton Aumark / Fuso Rosa / Jeep Grand Cherokee**  
**Part Number 100148-WL**

**The following steps are for Dodge Journey and Fiat Freemont vehicle models only.**

1. At the rear of the vehicle, remove the LHS tail light assembly fasteners and then remove the LHS tail light assembly.
2. Remove the rear passenger tool tray fasteners and then remove the tool tray.
3. Remove the luggage compartment rear trim.
4. Remove the luggage compartment rear upper trim.
5. Remove the luggage compartment LHS 'D' pillar trim seatbelt cap and fastener.
6. Remove the 'D' pillar trim.
7. Remove the LHS luggage compartment trim fasteners. Remove the LHS trim.

**Repeat for the RHS trim.**

8. Remove the LHS rear passenger's door sill trim.

**Repeat for the RHS trim.**

9. At the LHS tail light area, pull out the indicated grommet.
10. Cut into the grommet, ensuring the cut is large enough to feed in the Tail Harness (tail length 1800mm) connector.
11. Retrieve the Tail Harness from the tail light cavity area. Secure the Trailer Patch Harness (P/No: 100148-WL) ground ring terminal to the vehicle grounding point.
12. Secure the scotch locks to the vehicle harness wires and then connect the Trailer Patch Harness terminals to the corresponding wire colours as indicated on the table below:

Function	Trailer Patch	Vehicle Connector
L IND	YELLOW	WHITE / GREEN*
REVERSE	BLACK	BLACK / PURPLE
TAIL	BROWN	WHITE / PURPLE
BRAKES	RED	GREEN / WHITE

**\*Do not mistake for WHITE/LIGHT GREEN\***

13. Route the Trailer Patch Harness GREEN wire across the rear of the vehicle behind the vents, towards the RHS passenger 'C' pillar.
14. Locate the vehicle harness wires above the RHS wheel arch and scotch lock the 'WHITE/YELLOW' vehicle wire.



### Wiring Loom Fitting Instructions

To Suit Dodge Journey / Fiat Freemont / VW Transporter / Caravelle / Jeep Patriot /  
Compass / Multivan / Ford F250 / Foton Aumark / Fuso Rosa / Jeep Grand Cherokee  
Part Number 100148-WL

15. Connect the Trailer Patch Harness terminal to the scotch lock by referring to the table below:

Function	Trailer Patch	Vehicle Connector
R.IND	GREEN	WHITE / YELLOW

16. On the outside of the vehicle, mount the tail harness (tail length 1800mm) socket to the towbar mounting bracket using M4 fasteners (not supplied). Secure the harness with cable ties.
17. In the LHS rear quarter luggage compartment area, connect the Tail Harness 8-way male connector to the Trailer Patch Harness 8-way female connector.
18. Test the Trailer Harness function using a Light Board or multi-meter.
19. Secure all Harnesses using cables ties.
20. Re-fit all removed parts and secure all fasteners.
21. Place the instructions in the glove box after fitment.



**Wiring Loom Fitting Instructions**  
To Suit Dodge Journey / Fiat Freemont / VW Transporter / Caravelle / Jeep Patriot /  
Compass / Multivan / Ford F250 / Foton Aumark / Fuso Rosa / Jeep Grand Cherokee  
Part Number 100148-WL

**The following steps are for VW Transporter / Caravelle / Multivan vehicle models only.**

1. From outside the vehicle, remove the LHS tail light by first removing the two fasteners.

**Repeat step for the RHS.**

2. Remove the LHS lower rear trim by first removing any fasteners.

**Repeat step for the RHS.**

3. Remove the rear bumper by first removing any clips or fasteners.
4. Locate the LHS tail light harness.
5. Cut open the tail light harness to expose the wires.
6. Following the table below, connect the ezy taps to the vehicle harness wires ,then connect the trailer harness terminals to the corresponding wires by referring to the table below:

Function	Trailer Patch	Vehicle Connector
L.IND	YELLOW	BLACK / WHITE
REVERSE	BLACK	GREEN / BLACK
TAIL	BROWN	GREY / BLACK
BRAKES	RED	BLACK / RED

**Note: Use electrical tape to insulate the ezy taps and the vehicle tail light wires. Ensure it makes a good seal so they are protected from water.**

7. Route the trailer harness from the LHS, across the rear of the vehicle and towards the RHS.
8. Locate the RHS tail light harness.
9. Cut open the tail light harness to expose the wires.
10. Following the table below, connect the ezy tap to the vehicle harness wire, and then connect the trailer harness terminal to the corresponding wires.

Function	Trailer Patch	Vehicle Connector
R.IND	GREEN	BLACK / GREEN

**Note: Use electrical tape to insulate the ezy taps and the vehicle tail light wires. Ensure it makes a good seal so they are protected from water.**

11. Mount the trailer socket to the towbar mounting bracket using M4 fasteners (not supplied).



### Wiring Loom Fitting Instructions

To Suit Dodge Journey / Fiat Freemont / VW Transporter / Caravelle / Jeep Patriot /  
Compass / Multivan / Ford F250 / Foton Aumark / Fuso Rosa / Jeep Grand Cherokee  
Part Number 100148-WL

12. Route the tail harness (tail length 1200mm) across the rear of the vehicle and towards the LHS.
13. Connect the tail harness 8-way connector to the trailer harness mating 8-way connector.
14. Waterproof the two 8-way connectors using silicone or electrical grease.
15. Using a tech screw (not supplied), secure the trailer harness ground ring terminal to the vehicle body.
16. Test the trailer harness function using a light board or multi-meter.
17. Secure all harnesses using cables ties (not supplied).
18. Re-fit all removed parts and secure all fasteners, ensuring there are no squeaks or rattles.
19. Place the instructions in the glove box after fitment



# TRAILBOSS

## Wiring Loom Fitting Instructions To Suit Dodge Journey / Fiat Freemont / VW Transporter / Caravelle / Jeep Patriot / Compass / Multivan / Ford F250 / Foton Aumark / Fuso Rosa / Jeep Grand Cherokee Part Number 100148-WL

**The following steps are for Jeep Patriot / Compass vehicle models only.**

1. In the luggage compartment, remove the floor cover.
2. Fold the rear seats forward.
3. Remove the rear trim by first removing the two screws.
4. Dislodge the RHS side trim by first removing the screw.

### **Repeat for the LHS.**

5. Locate and remove the grommet from the LHS rear quarter of the luggage compartment.
6. Drill out the grommet hole to Ø30mm.
7. File any rough or sharp edges and spray on rust inhibitor.

**Note: If the grommet (1) is occupied, drill a Ø30mm hole in the floor of the luggage compartment in the indicated area (2).**

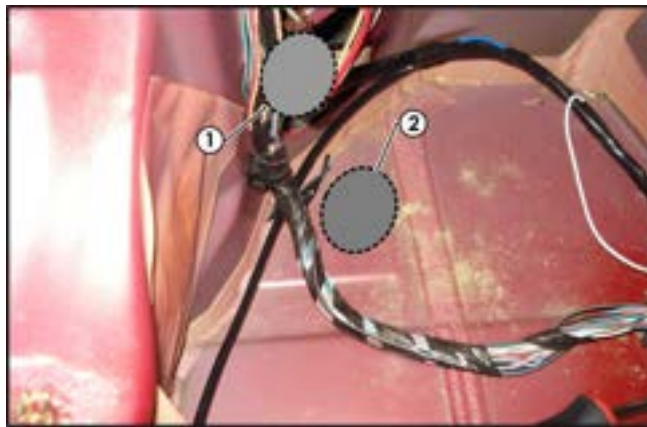

8. Locate the LHS vehicle harness.
9. Following the table below, connect the ezy taps to the vehicle harness wires, then connect the Trailer Harness (P/No: 100148-WL) terminals to the ezy taps.

Function	Trailer Patch	Vehicle Connector
L.IND	YELLOW	GREEN / RED
REVERSE	BLACK	WHITE / LT. GREEN
TAIL	BROWN	WHITE / PURPLE
BRAKES	RED	WHITE / ORANGE

10. Route the Trailer Harness across the rear of the luggage compartment and towards the RHS tail light area.



### Wiring Loom Fitting Instructions

To Suit Dodge Journey / Fiat Freemont / VW Transporter / Caravelle / Jeep Patriot / Compass / Multivan / Ford F250 / Foton Aumark / Fuso Rosa / Jeep Grand Cherokee  
Part Number 100148-WL

11. Locate the RHS vehicle harness.
12. Following the table below, connect the ezy taps to the vehicle harness wires, and then connect the Trailer Harness terminals to the ezy taps.

Function	Trailer Patch	Vehicle Connector
R.IND	GREEN	WHITE / YELLOW

13. Connect the Trailer Harness ground ring terminal to the LHS vehicle grounding point.
14. Mount the trailer socket to the towbar mounting bracket using M4 fasteners (not supplied).
15. Route the tail harness across the towbar, towards the RHS of the vehicle and up through the previously drilled out hole.
16. Ensure the tail harness grommet is seated correctly and secure in place using a cable tie (not supplied).
17. Connect the tail harness (tail length 1800mm) 8-way connector to the trailer harness mating 8-way connector.
18. Test the trailer harness function using a light board or multi-meter.
19. Secure all harnesses using cables ties (not supplied).
20. Re-fit all removed parts and secure all fasteners, ensuring there are no squeaks or rattles.
21. Place the instructions in the glove box after fitment.



**Wiring Loom Fitting Instructions**  
**To Suit Dodge Journey / Fiat Freemont / VW Transporter / Caravelle / Jeep Patriot /**  
**Compass / Multivan / Ford F250 / Foton Aumark / Fuso Rosa / Jeep Grand Cherokee**  
**Part Number 100148-WL**

**The following steps are for Ford F250 vehicle models only.**

1. On the outside of the vehicle, remove the LHS tail light by first removing the two screws.

**Repeat for the RHS.**

2. On the LHS of the rear tail light, following the table below, connect the ezy-tap to the corresponding vehicle wires, and then connect the trailer patch terminal to the ezy-tap.

Function	Trailer Patch	Vehicle Connector
L.IND	YELLOW	GREEN / WHITE
REVERSE	BLACK	BLACK / PINK
TAIL	BROWN	BROWN
BRAKES	RED	GREEN

3. Connect the Trailer Harness ground ring terminal to the LHS vehicle grounding point.
4. Route the Trailer Harness across the rear of the vehicle towbar and towards the RHS tail light area.
5. On the RHS of the rear tail light, following the table below, connect the ezy-tap to the corresponding vehicle wire, and then connect the trailer patch terminal to the ezy-tap.

Function	Trailer Patch	Vehicle Connector
R.IND	GREEN	WHITE / BLUE

6. Mount the trailer socket to the towbar mounting bracket using M4 fasteners (not supplied).
7. Route the tail harness (tail length 1200) through the cavity and towards the trailer harness mating connector.
8. Waterproof the Trailer Harness 8-way connector and the tail harness 8-way male connector using silicone or grease.
9. Connect the Tail Harness 8-way connector to the trailer patch 8-way mating connector.
10. Test the Trailer Harness function using a light board or multimeter.
11. Secure all harnesses using cables ties (not supplied).
12. Re-fit all removed parts and secure all fasteners, ensuring there are no squeaks or rattles.
13. Place the instructions in the glove box after fitment.

**Wiring Loom Fitting Instructions**  
 To Suit Dodge Journey / Fiat Freemont / VW Transporter / Caravelle / Jeep Patriot /  
 Compass / Multivan / Ford F250 / Foton Aumark / Fuso Rosa / Jeep Grand Cherokee  
 Part Number 100148-WL

**The following steps are for Foton Aumark vehicle models only.**

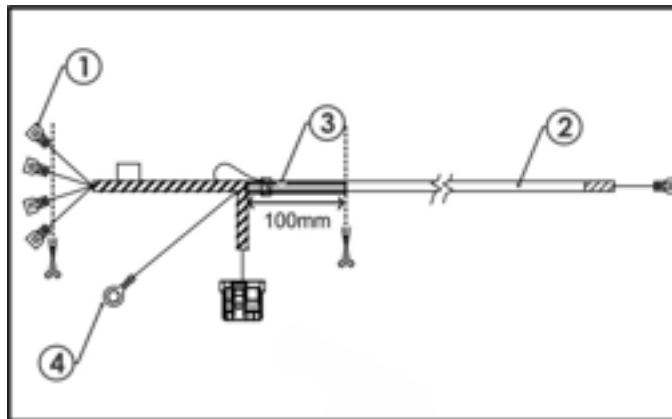

1. Cut the four male terminals (1) from the trailer patch (100148-WL).
2. Cut the single wire (3700mm length) (2) down to 100mm from the breakout (3).
3. Strip the previously cut wire (3) in order to solder to vehicle wiring.

**Note: Do not cut the ring terminal (4).**

4. On the outside of the vehicle, following the table below, solder the trailer patch wires to their corresponding vehicle wires on the LHS.

Function	Trailer Patch	Vehicle Connector
L.IND	YELLOW	GREEN / BLACK
REVERSE	BLACK	GREEN / PURPLE
TAIL	BROWN	GREEN
BRAKES	RED	YELLOW / GREEN
R.IND	GREEN	GREEN / YELLOW

5. On the LHS, disconnect the 12-way tail loom connectors to gain access to the vehicle grounding point.
6. Connect the earth ring terminal on the trailer patch to the vehicle grounding point.
7. Reconnect the 12-way tail loom connectors.
8. Mount the trailer socket to the towbar mounting bracket using M4 fasteners (not supplied).



### Wiring Loom Fitting Instructions

To Suit Dodge Journey / Fiat Freemont / VW Transporter / Caravelle / Jeep Patriot /  
Compass / Multivan / Ford F250 / Foton Aumark / Fuso Rosa / Jeep Grand Cherokee  
Part Number 100148-WL

9. Route the tail harness through the cavity and towards the trailer harness mating connector.
10. Waterproof the Trailer Harness 8-way connector and the tail harness 8-way male connector using silicone or grease.
11. Connect the Tail Harness 8-way connector to the trailer patch 8-way mating connector.
12. Test the Trailer Harness function using a light board or multimeter.
13. Secure all harnesses using cables ties (not supplied).
14. Re-fit all removed parts and secure all fasteners, ensuring there are no squeaks or rattles.
15. Place the instructions in the glove box after fitment.

## Wiring Loom Fitting Instructions

To Suit Dodge Journey / Fiat Freemont / VW Transporter / Caravelle / Jeep Patriot / Compass / Multivan / Ford F250 / Foton Aumark / Fuso Rosa / Jeep Grand Cherokee  
Part Number 100148-WL

### These following steps for Fuso Rosa vehicle models only.

1. On the LHS rear underside of the vehicle, locate the tail light wire corrugated tube. Cut through the corrugated tube (1) and following the table below, cut the trailer patch (P/No: 100148-WL) ezy-tap terminals off and solder the trailer patch wires (2) to the corresponding vehicle wires.

Function	Trailer Patch	Vehicle Connector
R.IND	GREEN	GREEN/YELLOW
L.IND	YELLOW	GREEN/BLUE
REVERSE	BLACK	RED/BLUE
TAIL	BROWN	BLUE/RED
BRAKES	RED	WHITE

**Note: Ensure all solder joints have sufficient solder and are taped up.**

Connect the trailer patch ground ring terminal (1) to the existing vehicle grounding point (2).



2. Mount the trailer socket to the tow bar mounting bracket using M4 fasteners (not supplied). Route the tail harness (tail length 1200mm) across the tow bar towards the LHS of the vehicle.
3. Connect the tail harness 8-way connector to the trailer patch 8-way mating connector. Waterproof the trailer patch 8-way connector and the tail harness 8-way male connector using silicone or grease
4. Test the trailer harness function using a Light Board or multimeter.
5. Secure all harnesses using cable ties (not supplied).
6. Re-fit all removed parts and secure all fasteners, ensuring there are no squeaks or rattles. Place the instructions in the glove box after fitment.



## Wiring Loom Fitting Instructions

To Suit Dodge Journey / Fiat Freemont / VW Transporter / Caravelle / Jeep Patriot / Compass / Multivan / Ford F250 / Foton Aumark / Fuso Rosa / Jeep Grand Cherokee  
Part Number 100148-WL

**The following steps are for Jeep Grand Cherokee vehicle models only.**

1. Remove the LHS and RHS rear tail light by removing its two fasteners and then disconnecting the connectors from behind.
2. On the RHS, cut through the harness tape on the tail lamp WHITE 3-way connector and following the table below, cut the ezy-tap terminals off the trailer patch harness (P/No: 100148) and solder the trailer patch wire to the corresponding vehicle wire. **Note: Ensure all solder joints have sufficient solder and are taped up. Secure all harnesses using cable ties (not supplied).**

Function	Trailer Patch	Vehicle Lamp / Connector	Vehicle Wire
R.IND	GREEN	RHS white 3-way connector	WHITE / YELLOW

3. Route the trailer patch harness through the tail light / bumper cavity and across the rear of the vehicle towards the LHS tail light.
4. On the LHS, cut through the harness tape on the tail lamp WHITE 3-way connector and following the table below, cut the ezy-tap terminals off the trailer patch harness (P/No: 100148) and solder the trailer patch wire to the corresponding vehicle wire. **Note: Ensure all solder joints have sufficient solder and are taped up.**

Function	Trailer Patch	Vehicle Lamp / Connector	Vehicle Wire
L.IND	YELLOW	LHS white 3-way connector	WHITE
TAIL	BLACK	LHS black 2-way connector	WHITE / GREY
BRAKES	BROWN	LHS black 3-way connector	WHITE / BROWN

5. Secure the trailer patch ground ring terminal to an appropriate location in the tail light cavity area on the vehicle sheet metal using a tek screw (not supplied).
6. In the luggage compartment area, remove the required trims to locate the LHS rear quarter vehicle harness. Locate the vehicle harness BLACK/WHITE wire. Cut the ezy-tap terminal off the trailer patch harness WHITE/GREEN and feed it into the vehicle and solder the trailer patch wire to the vehicle harness GREEN/WHITE reverse wire.

Function	Trailer Patch	Vehicle Wire
REVERSE	GREEN / WHITE	BLACK / WHITE

7. At the rear bumper cavity area, connect the tail harness 8-way connector to the trailer patch 8-way mating connector. **Waterproof the trailer patch 8-way connector and the tail harness 8-way male connector using silicone or grease.**
8. Test the Trailer Harness function using a light board or multimeter.
9. Secure all harnesses using cables ties (not supplied) and re-fit all removed parts and secure all fasteners, ensuring there are no squeaks or rattles. Place the instructions in the glove box after fitment.