

PRODUCT DETAILS:

Part Number:	QT1137L	Maximum Towing Braked:	1900	kg
ECU Number:	04837	Maximum Towing Unbraked:	750	kg
Tail Harness Length Required:	400 mm.	Maximum Static Ball Load:	190	kg
TBM/Lug Part Number:	21331			

FITTING DETAILS:

Towbar Installation Time:	45 Mins.	RPA Disable/Other:	YES
Total Installation Time:	85 Mins.	Note:	
Bumper Cut Required:	Yes	<ul style="list-style-type: none">• RPA Disable - Switch available on panel near hazard switch• Electric brake wire near Blue Connector	

TRAILBOSS RECOMMENDS THAT INSTRUCTIONS ARE READ AND UNDERSTOOD COMPLETELY PRIOR TO FITMENT.

BEFORE YOU START:

Check all hardware items have been included refer to assembly diagram.
Please ensure this towbar is only fitted to vehicle models as per Trailboss application guide.

Bumper Cuts

Vehicle and bumper variations can and do occur during vehicle manufacture after initial towbar design. Fitment of towbar to vehicle and accuracy of bumper cut must be assessed prior to any bumper modifications made. Incorrect bumper cuts are not covered under Trailboss warranty.

NOTE: Bumper cuts need to be approached with care, refer to notes below.

- Bumper centreline – where the centreline of the bumper needs to be determined, the installer must assess centre point by measurement of bumper width or determining two symmetrical reference points to give centreline.
- Bumper edge – To assist with accurate bumper cut measurement, reference to the start of the bumper edge is now being commonly used.
 - Measure from bottom edge along bumper and around corner to the 70 mm point (Figure 1).
 - Do not measure from visible bumper front of corner, upwards (Figure 2).

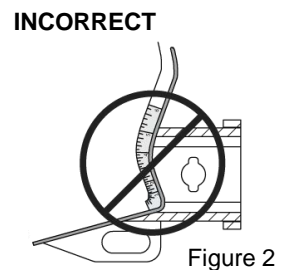
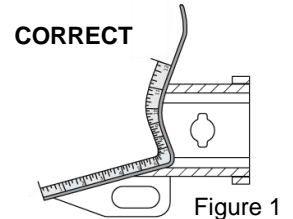

Drilling

- For any required drilling during installation, ensure that the area is clear of fuel, electrical & other components that may be damaged.
- All holes drilled into metal body panels shall have all burrs & swarf removed then coated with a suitable rust preventative paint.

Bolts/Fasteners

- Ensure that all hardware is fastened to correct torque as specified in this fitting instruction.
- All fasteners supplied with this product are used to achieve a specified clamp loading. If replacement is required ensure that fasteners of the same grade and class are used.

NOTE: Achieving correct torque is critical to proper installation and responsibility of the installer. Towbar failures attributed to tension issues from over tightening or under tightening are not covered by Trailboss warranty.

Product Labels

- a. Towbar load rating sticker provided with this product shall be conspicuously located on inside rear end of the driver's door.

WARNING:

Do not, drill, cut, weld or otherwise modify the towbar.

FOR TOWING PURPOSES ONLY - This towbar is designed and tested by Trailboss to adhere to ADR 62/02 which provides only for the expected load demands of towing.

i TOWBAR ASSEMBLY DIAGRAM

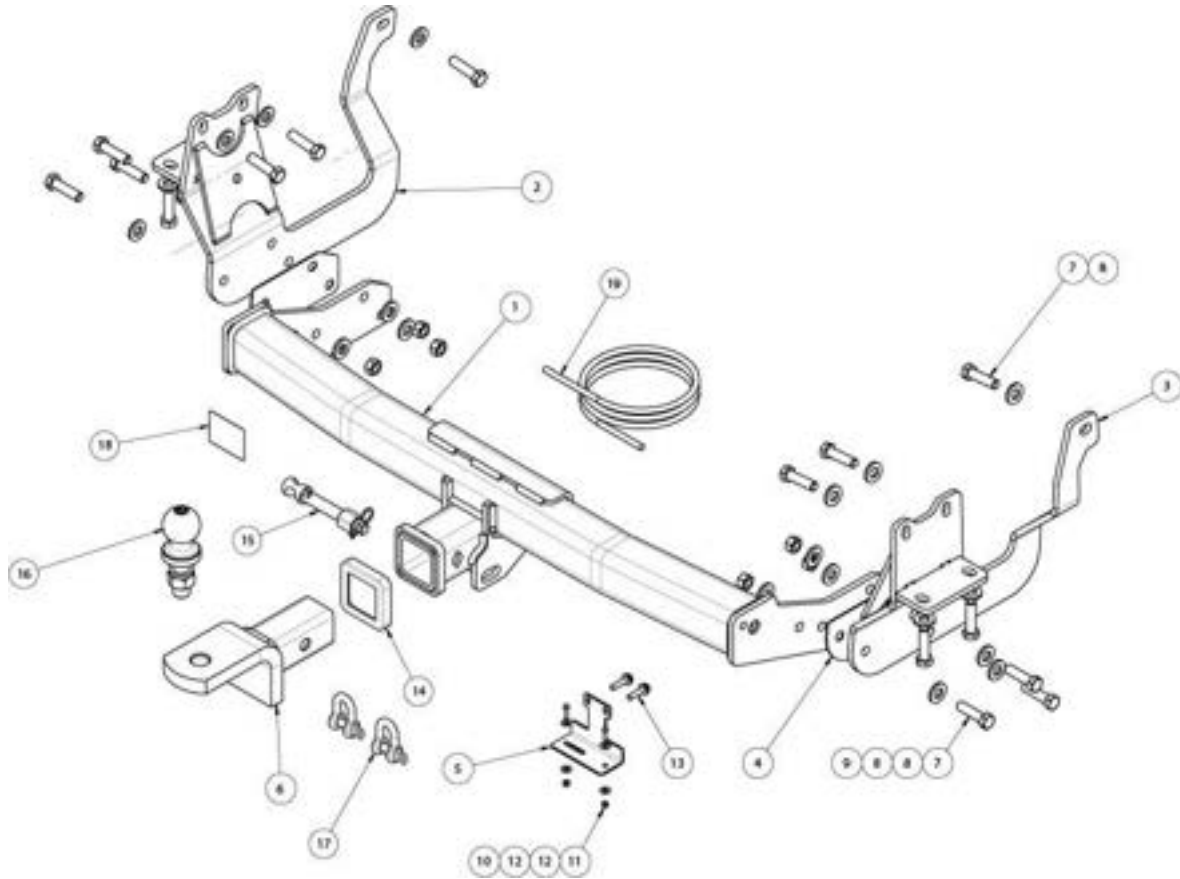

ITEM	DESCRIPTION	QTY
1	TOYOTA HIACE WELDED ASSY	1
2	SIDE ARM ASSY LH	1
3	SIDE ARM ASSY RH	1
4	SHIM PLATE	2
5	PLUG BRACKET	1
6	TRAILER BALL MOUNT	1
7	SET SCREW HEX HD M12x45x1.25P	16
8	WASHER PLAIN 1/2x1-1/8x16G	22
9	NUT HEX HD M12x1.25P	6
10	SCREW PAN HD M4x16x0.7P	2

ITEM	DESCRIPTION	QTY
11	NUT NYLON LOCK HEX M4x0.7P	2
12	WASHER PLAIN3/16x1/2x20G	4
13	TEK SCREW 14-20 HEX HD 22mm	2
14	HITCH BOX COLLAR COVER	1
15	SILENT HITCH PIN – SILVER	1
16	TOWBALL 50mm	1
17	"D" SHACKLE 10mm	2
18	ACRYLIC COMPLIANCE LABEL	1
19	WIRING LOOM	1

1. In wheel arch, remove 1 x small scrivet from bumper.

Remove 1 x scrivet from the plastic fender liner to the bumper located under the bumper.

Repeat for other side.

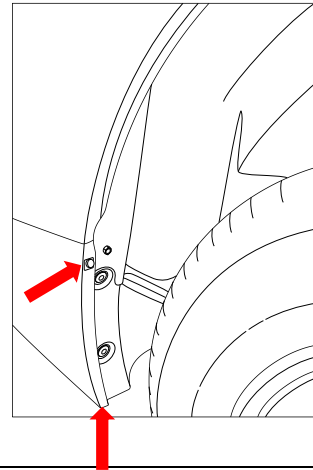

2. Under the bumper, remove 3 x scrivets from the bumper tabs.

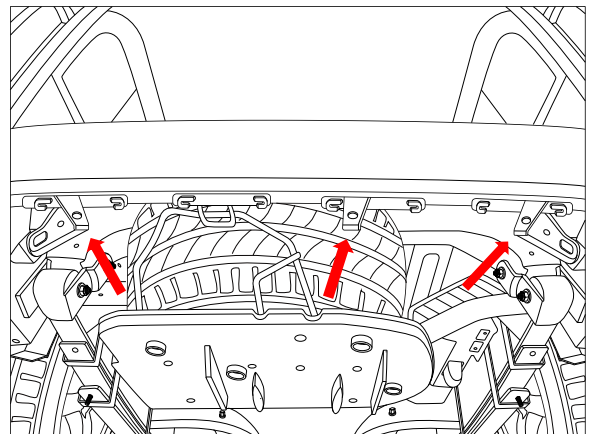

3. Open tailgate, remove tab and remove 1 x exposed bolt.

Repeat for other side.

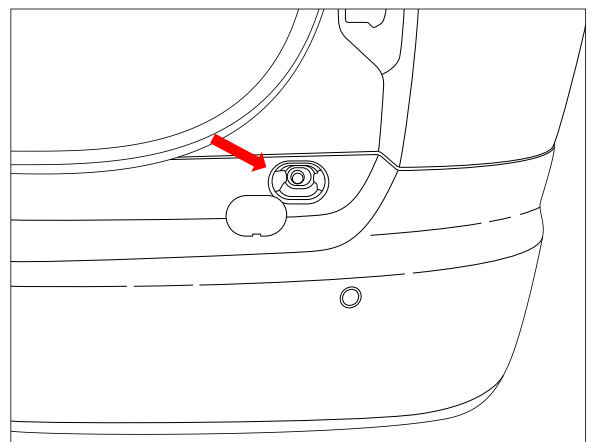

-
4. Disconnect sensor wiring harness located from under bumper on LH side.

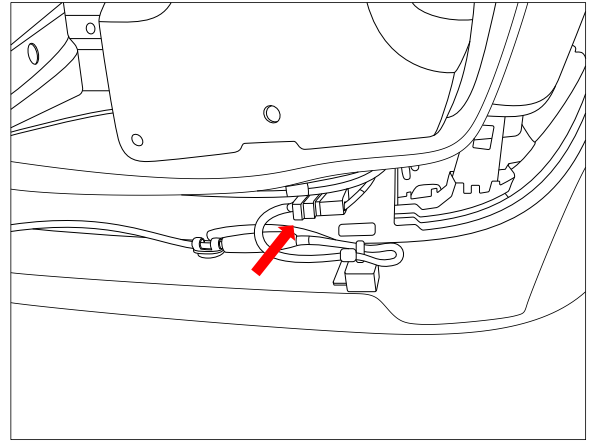

-
5. Peel away bumper from the sides and remove from vehicle. There is a clip near the taillights (LH & RH Side), accessible from under the bumper that requires slight depression to release bumper.

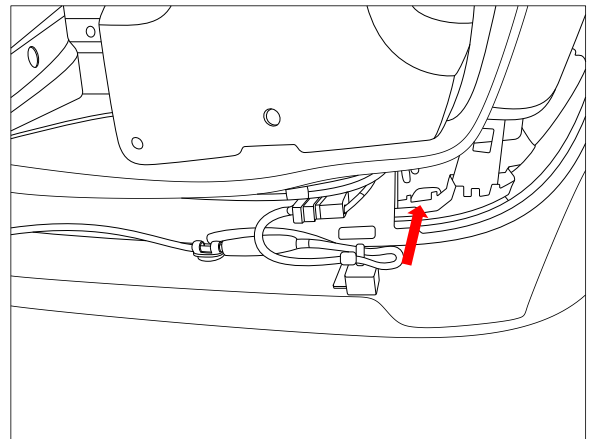

-
6. Remove and dispose the shipping bracket secured with 3 x bolts.

Repeat for other side.

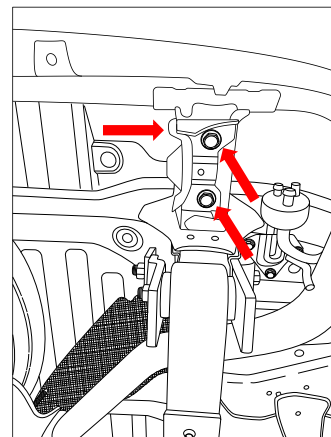

7. Fit the LH side arm assembly to the vehicle and loosely secure with 5 x M12 bolts complete with 1 x washer per bolt. Ensure that there is no clearance between the side arm and chassis at this step.

Repeat for other side

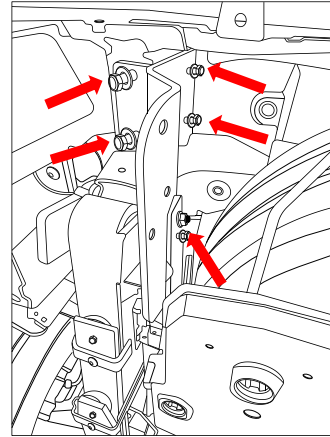

8. Lift crosstube to side arms and loosely secure each side with 3 x M12 bolts complete with 2 x washers and 1 x nut per bolt. Use the supplied shim plate to reduce excessive gaps between the side arms and cross tube where necessary.

Torque all fasteners to 125Nm.

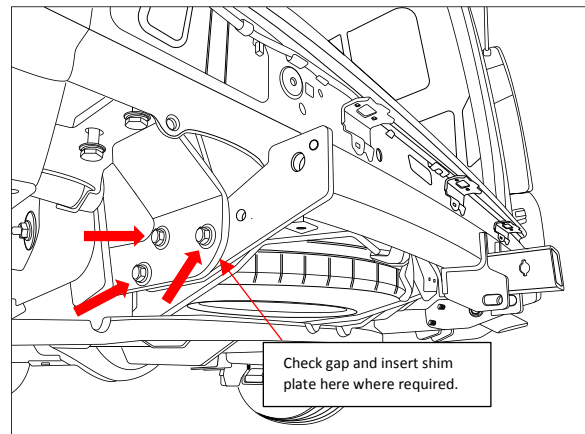

9. Place masking tape on the outside areas of Bumper bar skin so not to damage the surface while cutting. Establish the centre line of the bumper, then measure, mark, and cut out 85mm high and 90mm wide as shown in diagram using an appropriate tool. Ensure that cut is clean of swarf and rough edges.

Z

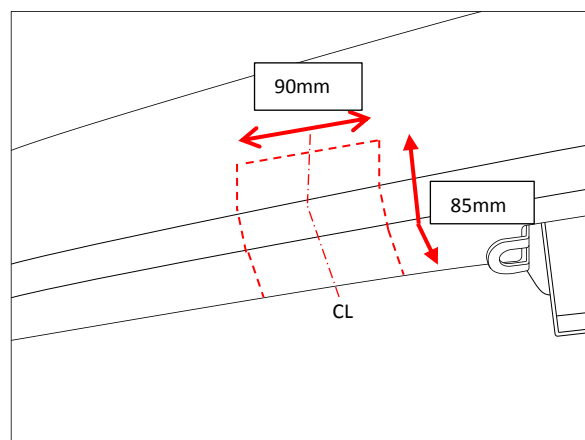

IMPORTANT

Due to possible vehicle variations, always confirm any noted vehicle colour wires with a multi-meter to ensure the correct function is identified before soldering or scotch locking. For vehicle wires denoted with two colours (example; RED/GREEN) the first colour will always be the main wire colour while the second colour is the thinner trace colour on the wire.

10. At the LHS passenger door, remove the 2 long trim covers on the passenger step.
11. Remove the passenger step (1) by first removing the 6 screws (2) and pulling in an upwards direction.

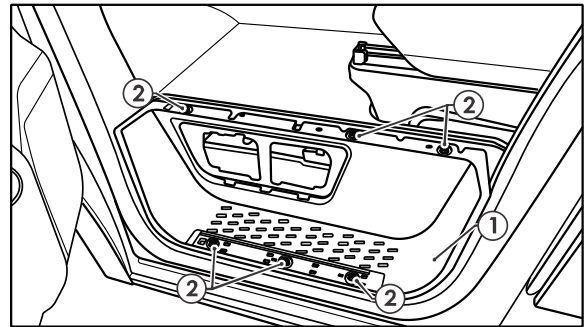

12. Lift the floor carpet to expose the battery cover screws.
13. Remove the battery cover (1) by first removing the 5 screws (2).
14. Disconnect the vehicle battery negative terminal.

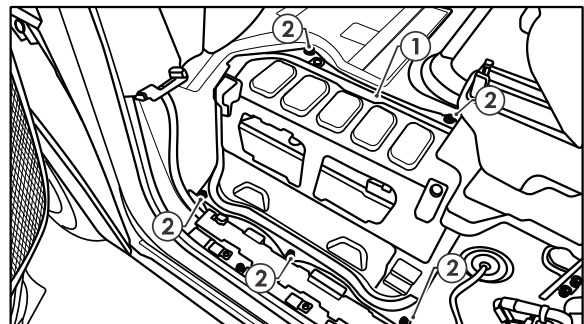

15. At the rear of the vehicle, remove the 3 screws **(1)** securing the LHS tail light assembly **(2)**.
16. Dislodge the tail light assembly **(2)**.
17. Disconnect the tail light assembly connector from the vehicle and remove.

Repeat for RHS

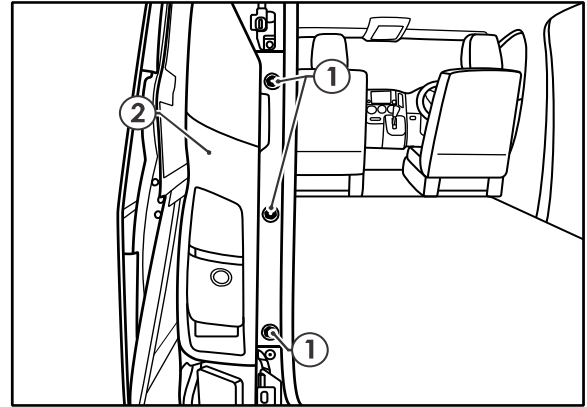

18. At the LHS tail light connector, patch in the LHS branch of the trailer patch (102231-WL) **(1)** in between the vehicle harness and the tail light.
19. Route the trailer patch **(1)** across to the RHS tail lamp. Secure with the supplied Cable Ties
20. Patch in the RHS branch of the trailer patch **(1)** in between the vehicle harness and the tail light.

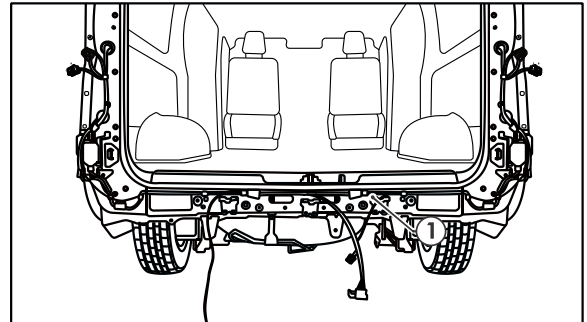

21. Locate a suitable area to mount the waterproof ECU (04837) **(1)**.
22. Connect the trailer patch 24-way connector **(2)** to the ECU **(1)** and Cable Tie to the sheet metal.

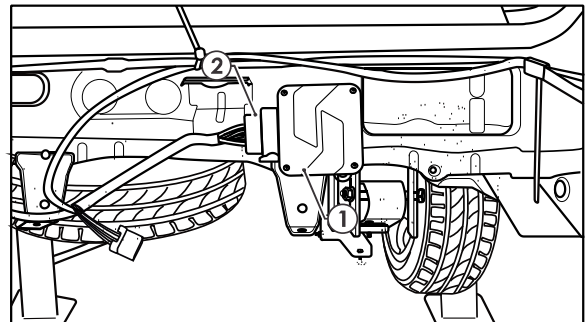

-
23. Route the ring terminals down the chassis towards the vehicle battery.
 24. Locate the small grommet (1) under the vehicle which leads into the battery tray.
 25. Feed the harness ring terminals and fuse holder (without 25amp fuse installed) through the grommet hole and seat the grommet in the hole.
Note: Keep harness routing clear of all sharp edges, moving parts and places of extreme heat.
Note: Ensure grommet is seated correctly and makes a good seal.

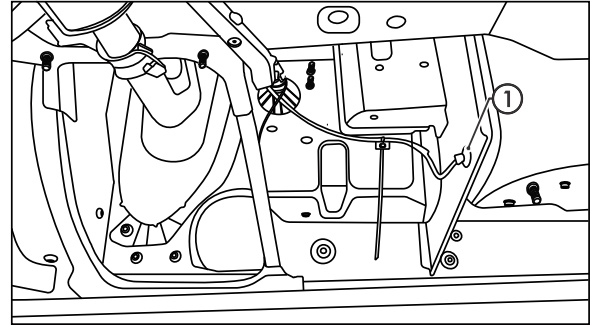

-
26. Inside the vehicle at the battery, pick up the ring terminals.
 27. Insert the supplied 25 Amp fuse into the fuse holder (1)
 28. Connect the fused power wire ring terminal (2) to the vehicle battery positive terminal (3).

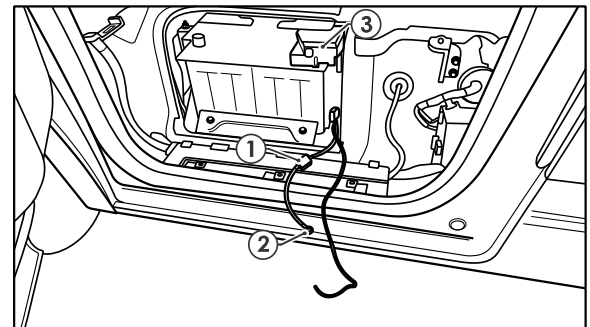

-
29. Connect the ground wire ring terminal to the vehicle earthing point (1).
Note: Due to the battery monitoring device (2) do not connect the earth point to the Negative post on the battery (3).

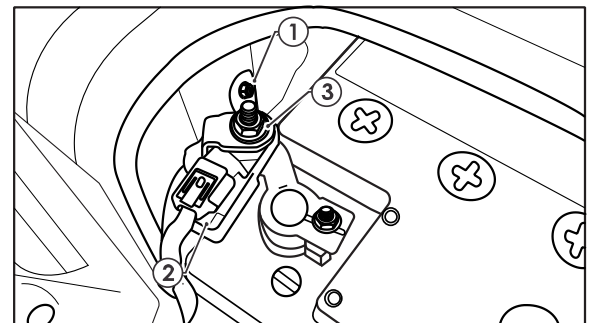

30. With the rear bumper removed, secure tail harness to towbar.

31. Connect the tail harness (tail length 400mm) 8-way connector (1) to the trailer patch mating 8-way connector (2).

32. Apply silicone grease (not supplied) (3) to waterproof connector.

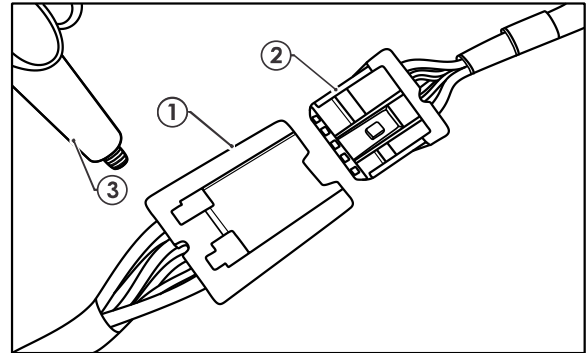

33. Secure all harness using supplied Cable Ties.

34. Test the trailer patch function using a light board or multi-meter.

35. Re-fit all removed parts and secure all fasteners, ensuring there are no squeaks or rattles.

36. The RPA function can be disabled via a switch (1) near the hazard switch

37. Place the fitting instructions in the glove box after fitment.

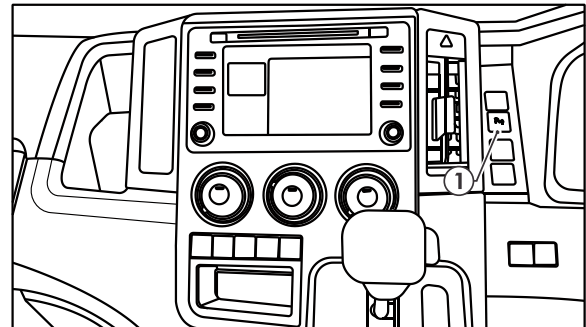

38. Position the plug bracket and tightly secure to the crosstube with 2 x tek screws.

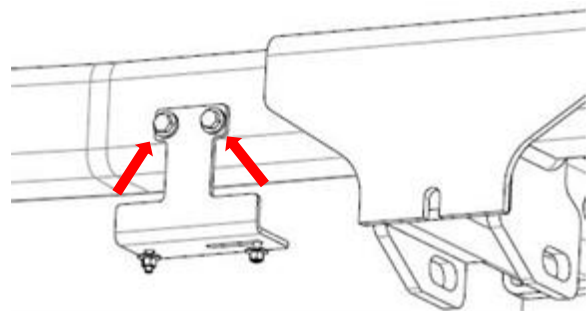



CUSTOMER INFORMATION

PLACE THESE INSTRUCTIONS IN THE
VEHICLE'S GLOVEBOX AFTER INSTALLATION

**THANK YOU FOR PURCHASING TRAILBOSS. WITH CORRECT MAINTENANCE AND CARE
THIS PRODUCT WILL PROVIDE A LIFETIME OF TROUBLE-FREE OPERATION.**

TOWBAR MAINTENANCE AND CARE:

1. Trailboss recommend that the towbar LUG or TBM (Trailer Ball Mount) Pull Pin and R-clip are removed and stored when not in use. Removal of LUG or TBM (Trailer Ball Mount) is advisable when not in use to assist with any of the following.
 - Ensure rear number plate is not obscured.
 - Allow maximum available departure angle and prevent any potential interference.
 - Prevent possible interference with vehicles reverse sensors or camera detecting a tow ball mount as an obstruction during reversing.
 - Removes towball mount as an obstruction for when moving around the rear of the vehicle.
2. Trailboss recommends routine inspection of your towbar to ensure trouble free towing.
 - Bolt security and tension should be regularly inspected and checked for correct tension. Replace any worn or defective parts with suitable grade & class fasteners. Inspection should be requested to coincide with vehicle major services.
3. It is the owner's responsibility to ensure towing and down ball weight capacities of the towing vehicle are not exceeded.
 - Towing and down ball weights allowable may differ according to model variations. Please refer to owner's manual or vehicle dealer to confirm exact rating for your vehicle model variant.
 - It is not uncommon for the vehicle tow rating to differ from the towbar rating. When this occurs, the lesser rating must be adhered to.
 - For vehicles fitted with enhanced vehicle functions that may be altered/changed when towing i.e Trailer sway mitigation, blind spot detection, adaptive cruise control etc. Please consult owner's manual to understand changes enabled when towing and after towing.

WARRANTY INFORMATION:

Trailboss Towbars are covered by a Lifetime Warranty.

Our goods come with guarantees that cannot be excluded under the Australian Consumer Law. You are entitled to a replacement or refund for a major failure and for compensation for any other reasonably foreseeable loss or damage. You are also entitled to have the goods repaired or replaced if the goods fail to be of acceptable quality and the failure does not amount to a major failure.

For further details please contact customer service on 1800 812 017.

PRO SERIES SILENT ANTI-RATTLE HITCH PIN

Your Trailboss towbar is equipped with a Pro Series Silent Anti-Rattle Hitch Pin technology to help reduce towbar tongue rattle in most driving conditions. Please ensure below instructions are understood and routine maintenance is carried out to ensure best towing experience.

Regularly inspect for wear and check the tightness of the Silent Anti-Rattle Hitch Pin. Follow instructions below to re-tighten the nut as necessary when movement and noise in the tow ball mount is noted.

- Before towing, ensure R-Clip is properly installed and hitch pin nut is installed and tensioned. Replacement parts are available from your Pro Series Distributor.

TOWBALL MOUNT REMOVAL/INSTALLATION

STEP 1

Insert Trailer Ball Mount (TBM) (a) into towbar hitchbox (b), aligning hole in TBM shank (c) with hole in hitchbox (d) (Fig. 1)

STEP 2

Insert Silent Anti-Rattle Hitch Pin (e) through hole in hitchbox and hole in TBM shank (g); ensure the locators are inserted into the notches in the hitchbox (Fig. 2)

STEP 3

Screw Silent Anti-Rattle Hitch Pin (f) onto Smart Pin (g); tighten Smart Pin Nut until finger tight, ensuring TBM is restrained from up and down movement.

STEP 4

Tighten Silent Anti-Rattle Hitch Pin Nut by turning nut a further 1/8th of a turn in the clockwise direction using a 24mm spanner (Fig. 4).

STEP 5

Install Silent Anti-Rattle Hitch Pin R-Clip through the hole that provides best clearance or easiest access. (Fig. 5)

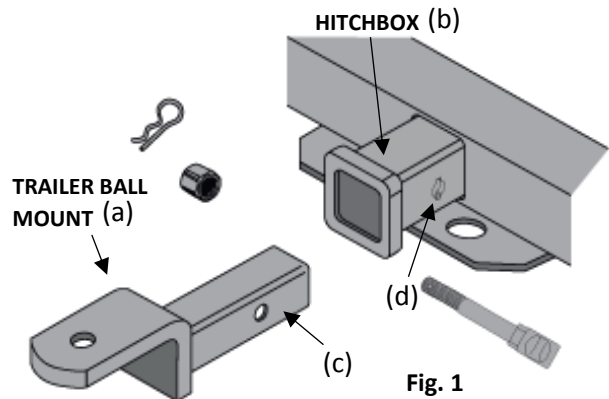

Fig. 1

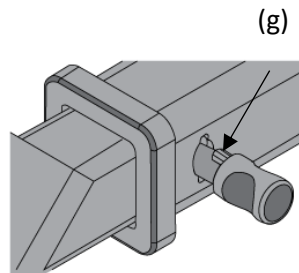

Fig. 2

SILENT ANTI-RATTLE HITCH PIN NUT (f)

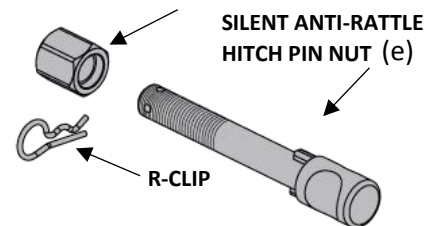

Fig. 3

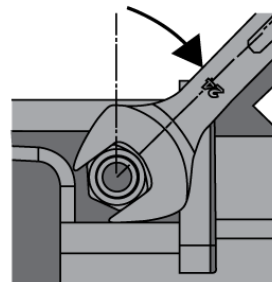

Fig. 4

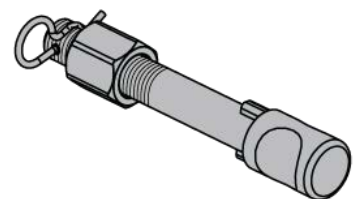

Fig. 5