

# TRAILBOSS

## Towbar Fitting Instructions To Suit **AUDI Q5 2012 ON** Part Number **QTAU3L** Rating **2000/200 kg**

PLACE THESE INSTRUCTIONS IN THE VEHICLE'S GLOVEBOX AFTER INSTALLATION IS COMPLETE

### **WARNING:**

1. Do not, drill, cut, weld or otherwise modify the tow bar.
2. If you are using electric welding on a motor vehicle, **always** check that the vehicle is not equipped with electronic engine or instrument management equipment. Failure to do so could **destroy** any onboard computers. If in doubt, check with the vehicle's manufacturer.
3. The high tensile fasteners supplied with this product were used to achieve the specified rating. If replacement is required ensure that fasteners of the same rating & quality are used. Contact an authorised **Trailboss** dealer if further information is required.

### **General:**

1. Ensure all hardware items have been included refer to assembly diagram.
2. It is recommended that the instructions are read through and completely understood before making any attempt to fit this product.
3. Be wary of any changes to vehicle designs or other accessories that may conflict with the installation of this product.
4. Before drilling ensure that the area is clear of fuel, electrical & other components.
5. All holes drilled into the body panels shall have all burrs & swarf removed then coated with a suitable rust preventative paint.
6. For vehicles that require the bumper to be cut. Ensure cut out area is in correct position on the vehicle prior to cutting the bumper.
7. The high tensile fasteners supplied with this product were used to achieve the specified rating. If replacement is required ensure that fasteners of the same rating & quality are used. Contact an authorized **Trailboss** dealer if further information is required.
8. Ensure that all hardware is fastened to torque list below check fasteners on regular basis.
9. Tow bar load rating sticker provided with this product shall be conspicuously located on inside rear end of the driver's door. **(See diagram below)**.
10. Trailboss recommends that you check your tow ball to ensure that it complies with the Australian standards **AS 4177.2**.
11. **PLEASE NOTE:** It is advised to remove your lug or tbn when not actually towing so as to produce a clear view of the vehicles registration plate if obscured, and to also provide maximum available departure angle
12. Pull Pin must be fit in down position.

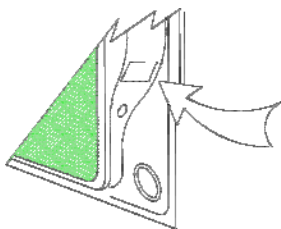

Place load rating sticker  
inside driver's door here

**FOR TRAILER TOWING PURPOSES ONLY**  
For towing capacity details please refer to vehicle owner's manual or to the manufacturer. Overloading can void your warranties.

#### RECOMMENDED ASSEMBLY TORQUE LISTING

Diameter	Grade 8.8 Bolt
M6	9.5 Nm
M8	21.7 Nm
M10	43.4 Nm
M12	77.3Nm
M14	146 Nm
M16	189.8 Nm

### **Tow bar Maintenance and Care.**

Trailboss recommends that bolt torque's, as listed below, are routinely and regularly inspected and checked for correct tension. Replace any worn or defective parts.

We recommended to remove Tow Ball Mounts (TBM's, tongues or lugs) when not being used for any considerable length of time.

So as to avoid injury, when not towing it is suggested that the tongue, Pull Pin and R-clip are removed then stored in a safe, clean and dry place, away from excessive moisture.

Hitch Pull Pins and spring "R" clips are regularly checked for proper installation. Replace any worn or defective parts.

# TRAILBOSS

Towbar Fitting Instructions  
 To Suit **AUDI Q5 2012 ON**  
 Part Number **QTAU3L**  
 Rating **2000/200 kg**

PLACE THESE INSTRUCTIONS IN THE VEHICLE'S GLOVEBOX AFTER INSTALLATION IS COMPLETE

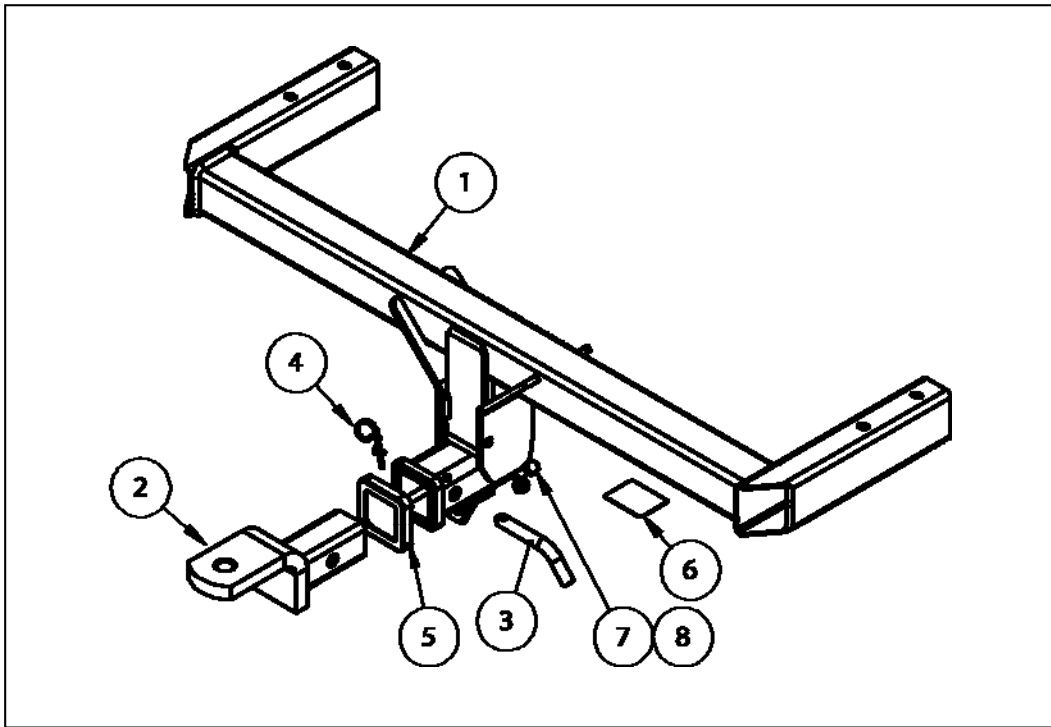

QTY	DESCRIPTION	ITEM NO
1	WELDED ASSY	1
1	TBM	2
1	PULL PIN	3
1	RCLIP	4
1	HITCH BOX COLLAR COVER	5
1	CP LABEL	6
1	M10 BOLT	7
1	M10 HEX NUT	8

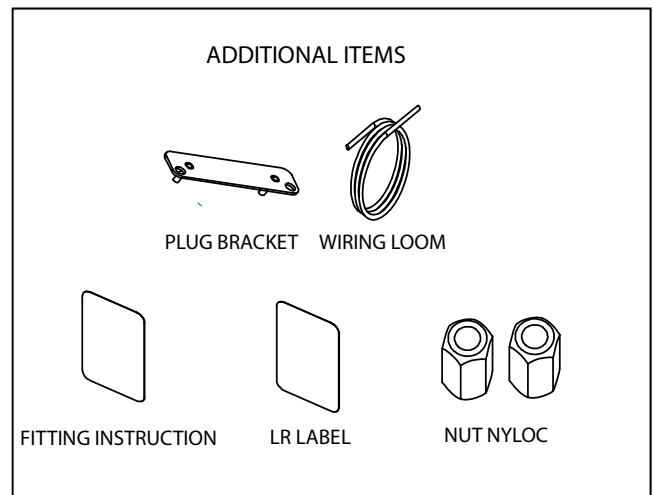



Towbar Fitting Instructions  
To Suit **AUDI Q5 2012 ON**  
Part Number **QTAU3L**  
Rating **2000/200 kg**

PLACE THESE INSTRUCTIONS IN THE VEHICLE'S GLOVEBOX AFTER INSTALLATION IS COMPLETE

**INSTRUCTION:**

1. Remove 3 x Torx Screws under Wheel Arch on both sides.
2. Remove 2 x Screws under Rear Bumper.
3. Remove Rear Step Panel via lift vertical up, disconnect wiring near latching cover.  
Remove 2 x Nuts holding the Bumper from inside Rear Panel.
4. Remove Side Cover on both sides to remove 2 x Nuts holding the Bumper. Remove compressor and tray to gain access to the nut.  
Release the Bumper skin via flexing the Bumper outward. Disconnect any wiring before completely removing the Bumper Skin.
5. Remove 4 x Hook Brackets with Torx Key; remove 2 Side Panels to gain access to the Mounting Bracket.
6. Remove 2 x Bolts which holding the Hook Bracket on both sides. Retain Bolts for reuse. Remove Impact Beam and discard.
7. Insert Towbar in replacement of Impact Beam. Reinstall Hook Bracket. Torque bolts to specifications listed on Page 1.  
Remove Lower Cover off the Bumper Skin and reinstall the Bumper Skin to the vehicle.
8. Cut Lower Cover 90x140 mm, find centreline and mark 45mm from each sides. Cut 90mm section with 90mm gap from the lower end of the Bumper (Rear). Install Lower Cover back to the Bumper Skin.

**NOTE: For Models without Bumper pop out, Bumper cut should be make from the scribed or lined section on the inside of the Bumper.**



Wiring Loom Fitting Instructions  
To Suit Audi Q5  
Part Number 100629-WL

## Wiring Loom Installation Instructions

Audi Q5  
Part No: 100629-WL

Tail Harness Length Required: 1200mm  
Diesel models up to MY11 – ECU Required Part No: 04828  
All other models – ECU Required Part No: 04826

RPA can be disabled via the dashboard switch

Wiring Loom Installation Time: Approx. 45 Mins

## Wiring Loom Fitting Instructions To Suit Audi Q5 Part Number 100629-WL

**NOTE: THE TRAILER LIGHTS DO NOT WORK WHEN THE TAIL GATE IS OPEN.**

1. In the luggage compartment, remove the following items from the vehicle: Rear sun shade, floor carpet and RHS storage net.
2. Dislodge the RHS luggage compartment trim, disconnect the trim light connector and then remove the RHS trim.
3. Dislodge the rear luggage compartment trim and then disconnect the trim connector.
4. Underneath the rear bumper, remove the two trim fasteners and then remove the trim.
5. Drill a Ø30mm hole (1) into the vehicle sheet metal.
6. File any rough or sharp edges and spray on rust inhibitor.

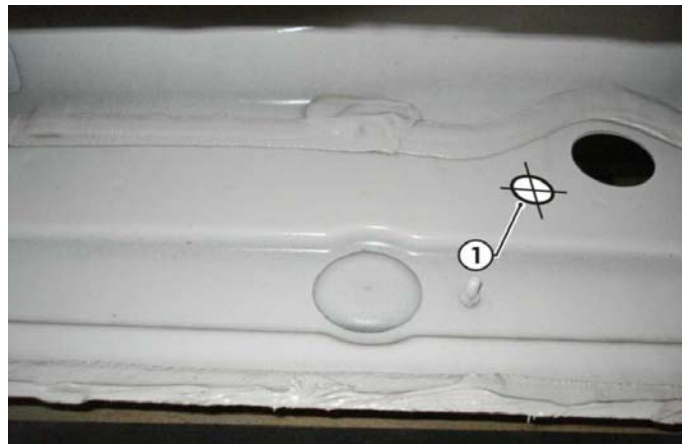

**Steps 7 – 8 are for all models except Diesel models MY09 to MY11.**

7. Connect the extension patch 12-way female connector to the ECU (04826).
8. Connect the extension patch 12-way male connector to the trailer wiring harness 12-way female connector.

**Step 9 is for Diesel models MY09 to MY11 only.**

9. Connect the 12-way female connector to the ECU (04828).
10. On the rear of the luggage compartment, reconnect the rear trim panel connector and reattach the trim.

**Note: Ensure to reconnect the rear trim panel before continuing with any of the wiring fitment, as this will ensure the micro switch will trigger the light output on the tailgate.**

**Note: Ensure the micro switch & tailgate latch are engaged to enable tailgate light functionality.**



Wiring Loom Fitting Instructions  
To Suit Audi Q5  
Part Number 100629-WL

11. Route the trailer wiring harness terminals towards the RHS rear quarter black connector box.
12. Following the table below, connect the supplied ezy-taps to the corresponding wires on the BROWN and BLACK connectors.

**The following step is for is for MY09 to MY11 Diesel models only.**

13. Connect the trailer wiring harness terminals to the corresponding ezy-taps.

Function	Trailer Patch	Vehicle Connector	Connector
R.IND	GREEN / BLACK	BLACK / GREEN	BROWN
L.IND	YELLOW / BLACK	BLACK / BLUE	BLACK
BRAKES / TAIL	BROWN / BLACK	BLACK / BLUE	BLACK
REVERSE	BLACK / WHITE	GREY (4th Wire)	BLACK

**The following step is for is for all other MY09 to MY12 models only.**

14. Following the table below, connect the supplied ezy-taps (1) to the corresponding wires (2) to the RHS tail light assembly area.

Function	Trailer Patch	Vehicle Connector	Connector
R.IND	GREEN / BLACK	BLACK / GREEN	BROWN
L.IND	YELLOW / BLACK	BLACK / BLUE	BLACK
BRAKES	BROWN / BLACK	BLACK / BLUE	BLACK
REVERSE	BLACK / WHITE	GREY (4th Wire)	BLACK
TAIL	BROWN / BLACK (Patch)	YELLOW	-

**The following step is for is for MY12 – Onwards models only.**

15. Following the table below, connect the supplied ezy taps to the corresponding wires to the RHS tail light assembly area.

Function	Trailer Patch	Vehicle Connector	Connector
R.IND	GREEN / BLACK	GREY (5TH)	BLACK
L.IND	YELLOW / BLACK	GREY / BLACK	BROWN
BRAKES	BROWN / BLACK	BLACK / GREEN	BROWN
REVERSE	BLACK / WHITE	GREY (7th Wire)	BLACK
TAIL	BROWN / BLACK (Patch)	GREY / BLUE	BROWN

16. Remove the fuse panel row 'C' plastic casing.
17. Slot the supplied 20 amp fuse into the upper slot of the add-a-fuse harness.
18. Connect the add-a-fuse harness to the mating trailer wiring harness connector.
19. Insert the add-a-fuse harness fuse connector into either of the empty slots on row 'C'  
**Note: The two empty slots sit next to the 7.5 amp fuse.**
20. Secure the ECU to the existing vehicle harness using a cable tie (not supplied).



Wiring Loom Fitting Instructions  
To Suit Audi Q5  
Part Number 100629-WL

21. Secure the trailer wiring harness ground ring to a suitable location on the sheet metal using a tek screw (not supplied).
22. From the outside of the vehicle, mount the trailer socket to the towbar mounting bracket using M4 fasteners (not supplied).
23. Route the tail harness across the towbar towards the LHS of the vehicle and up through the previously drilled out hole.
24. Ensure the tail harness grommet is seated correctly and secure in place using a cable tie (not supplied).
25. Connect the tail harness 8-way connector to the trailer wiring harness mating 8-way connector.
26. Test the trailer harness function using a light board or multimeter.
27. Secure all harnesses using cables ties (not supplied).
28. Re-fit all removed parts and secure all fasteners, ensuring there are no squeaks or rattles.
29. Place the instructions in the glove box after fitment.