

TRAILBOSS

Towbar Fitting Instructions
To Suit **AUDI A3 SPORTBACK 8V – 05/2013 ONWARD**
Part Number **QTAU4L**
Rating **1800/75 kg**

PLACE THESE INSTRUCTIONS IN THE VEHICLE'S GLOVEBOX AFTER INSTALLATION IS COMPLETED

WARNING:

1. Do not, drill, cut, weld or otherwise modify the tow bar.
2. If you are using electric welding on a motor vehicle, **always** check that the vehicle is not equipped with electronic engine or instrument management equipment. Failure to do so could **destroy** any onboard computers. If in doubt, check with the vehicle's manufacturer.
3. The high tensile fasteners supplied with this product were used to achieve the specified rating. If replacement is required ensure that fasteners of the same rating & quality are used. Contact an authorised **Trailboss** dealer if further information is required.
4. If TBM is used in inverted position tow ball may make contact with rear tailgate when lowered, which could cause damage.

General:

1. Ensure all hardware items have been included refer to assembly diagram.
2. It is recommended that the instructions are read through and completely understood before making any attempt to fit this product.
3. Be wary of any changes to vehicle designs or other accessories that may conflict with the installation of this product.
4. Before drilling ensure that the area is clear of fuel, electrical & other components.
5. All holes drilled into the body panels shall have all burrs & swarf removed then coated with a suitable rust preventative paint.
6. For vehicles that require the bumper to be cut. Ensure cut out area is in correct position on the vehicle prior to cutting the bumper.
7. The high tensile fasteners supplied with this product were used to achieve the specified rating. If replacement is required ensure that fasteners of the same rating & quality are used. Contact an authorized **Trailboss** dealer if further information is required.
8. Ensure that all hardware is fastened to torque list below check fasteners on regular basis.
9. Tow bar load rating sticker provided with this product shall be conspicuously located on inside rear end of the driver's door. **(See diagram below).**
10. Trailboss recommends that you check your tow ball to ensure that it complies with the Australian standards **AS 4177.2**.
11. **PLEASE NOTE:** It is advised to remove your lug or tbm when not actually towing so as to produce a clear view of the vehicles registration plate if obscured, and to also provide maximum available departure angle
12. Pull Pin must be fit in down position.

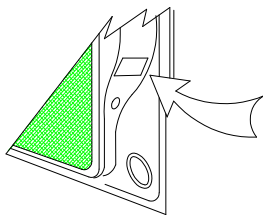

Place load rating sticker
inside driver's door here

FOR TRAILER TOWING PURPOSES ONLY
For towing capacity details please refer to vehicle owner's manual or to the manufacturer. Overloading can void your warranties.

RECOMMENDED ASSEMBLY TORQUE LISTING

Diameter	Grade 8.8 Bolt
M6	9.5 Nm
M8	21.7 Nm
M10	43.4 Nm
M12	77.3Nm
M14	146 Nm
M16	189.8 Nm

Tow bar Maintenance and Care.

Trailboss recommends that bolt torque's, as listed below, are routinely and regularly inspected and checked for correct tension. Replace any worn or defective parts.

We recommended to remove Tow Ball Mounts (TBM's, tongues or lugs) when not being used for any considerable length of time.

So as to avoid injury, when not towing it is suggested that the tongue, Pull Pin and R-clip are removed then stored in a safe, clean and dry place, away from excessive moisture.

Hitch Pull Pins and spring "R" clips are regularly checked for proper installation. Replace any worn or defective parts.

TRAILBOSS

Towbar Fitting Instructions
 To Suit **AUDI A3 SPORTBACK 8V – 05/2013 ONWARD**
 Part Number **QTAU4L**
 Rating **1800/75 kg**

PLACE THESE INSTRUCTIONS IN THE VEHICLE'S GLOVEBOX AFTER INSTALLATION IS COMPLETED

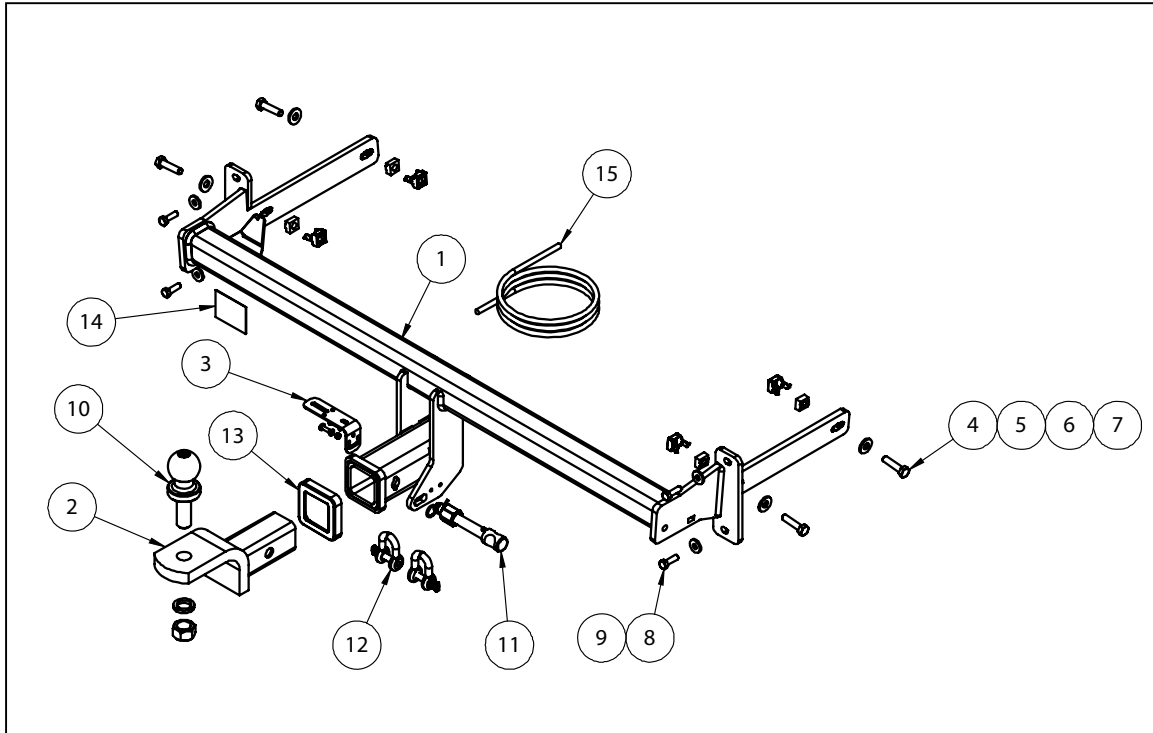

QTY.	DESCRIPTION	ITEM NO.
1	WELDED ASSY	1
1	TBM ASSY	2
1	UNIVERSAL PLUG BRACKET KIT	3
4	BOLT M12-1.5x40mm	4
4	WASHER FLAT M10x25.4x3	5
4	CAGE NUT M10X1.5	6
4	CAGE NUT RETAINER	7
4	SET SCREW M8x25	8
4	FLAT WASHER M8x22x3.3mm	9
1	50mm TOWBALL	10
1	SILENT HITCH PIN - SILVER	11
2	10mm "D" SHACKLE	12
1	HITCH BOX COLLAR COVER	13
1	ACRYLIC CP	14
1	WIRING LOOM	15



Towbar Fitting Instructions
To Suit **AUDI A3 SPORTBACK 8V – 05/2013 ONWARD**
Part Number **QTAU4L**
Rating **1800/75 kg**

PLACE THESE INSTRUCTIONS IN THE VEHICLE'S GLOVEBOX AFTER INSTALLATION IS COMPLETED

INSTRUCTION:

1. Remove 3x Screws from within rear wheel arch. Repeat for opposite side of the vehicle.
2. Remove 1x Screw from within rear wheel arch, securing bumper to body work. Repeat for opposite side of the vehicle.
3. Remove 2x Screws from underside of rear bumper.
4. Remove boot floor.
5. Unclip and remove rear boot interior trim.
6. Remove boot interior side panel. Remove Nut securing tail light assembly. Repeat for opposite side of the vehicle.
7. Remove and disconnect tail light assembly. Repeat for opposite side of the vehicle.
8. Remove 4x Nuts from inside boot, securing rear bumper to chassis.

Note that a long socket may be required to access nuts over locating studs.
9. Remove plastic locking Pin at outer edge of bumper, below tail light assembly location. Repeat for opposite side of the vehicle.
10. Carefully unclip and remove rear bumper; store in a safe location. Disconnect rear parking sensor loom as bumper is removed.
11. Remove and discard 8x Set Screws (4x Set Screws per side) securing impact beam to rear panel of vehicle. Remove and discard impact beam.
12. Offer Towbar to vehicle, sliding sidearms into chassis rails.
13. Loosely secure sidearms to chassis rails using 2x M10 Bolts per sidearm, complete with 1x M10 Flat Washer per Bolt.
14. Loosely secure rear panel mount of Towbar to rear panel of vehicle using 2x M8 Set Screws per side, complete with 1x M8 Flat Washer per Set Screw.
15. Tighten the 4x M10 Bolts and 4x M8 Set Screws to torques specified on page 1 of this document.
16. Secure plug bracket to LHS of Hitch receiver using fasteners provided.
17. Separate lower section of rear bumper from main bumper fascia.
18. Create bumper cut in bumper lower section as per dimensions shown. Add pinch weld provided to edge of Bumper cut.
19. Reinstall bumper following steps 1 to 10 & 17 in reverse order.



Towbar Fitting Instructions
To Suit **AUDI A3 SPORTBACK 8V – 05/2013 ONWARD**
Part Number **QTAU4L**
Rating **1800/75 kg**

PLACE THESE INSTRUCTIONS IN THE VEHICLE'S GLOVEBOX AFTER INSTALLATION IS COMPLETED

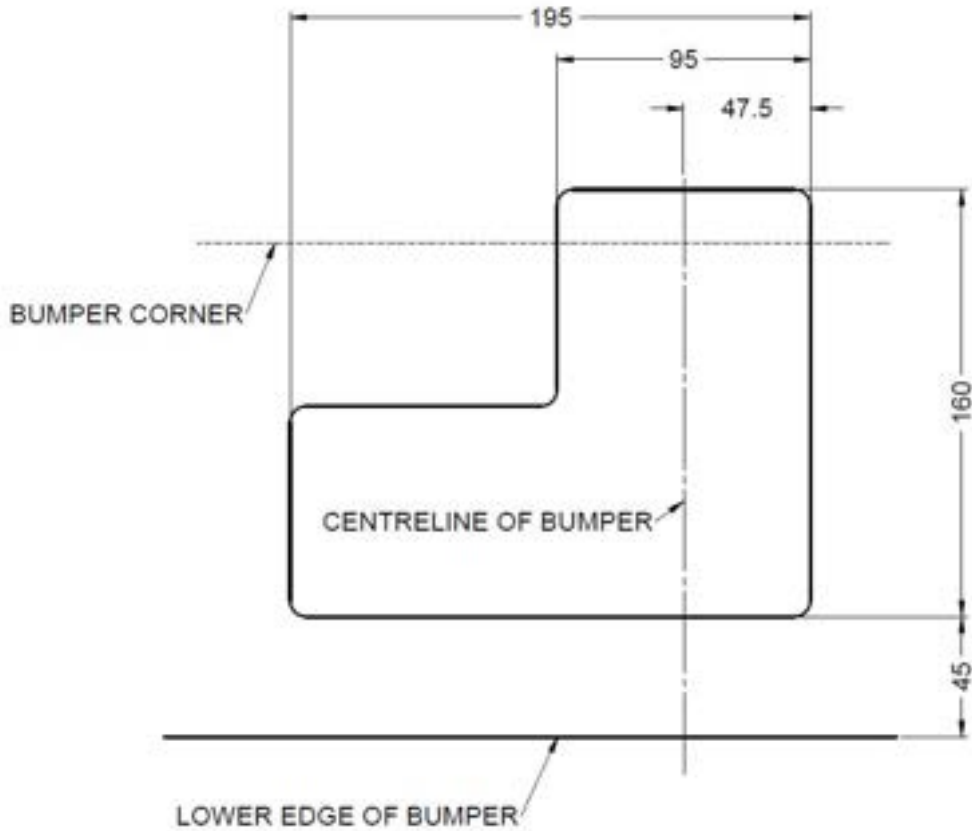



Wiring Loom Fitting Instructions
To Suit Audi A3 MY15
Part Number 101238-WL

Wiring Loom Installation Instructions

Audi A3 MY15
Part No: 101238-WL

Tail Harness Length Required: 1200mm
ECU Required: 04826
Power Harness Part No: 04825

Wiring Loom Installation Time: Approx 50 Mins



Wiring Loom Fitting Instructions
To Suit Audi A3 MY15
Part Number 101238-WL

1. At the rear of the vehicle remove the parcel shelf.
2. Remove the cargo net (if fitted).
3. Remove the floor carpet cover and fold down the rear seats.
4. Remove the luggage compartment rear trim.
5. Dislodge the luggage compartment LHS access panel and disconnect the 12v connector from the LHS access panel and then remove the access panel.
6. Remove the trim fasteners.
7. Remove the luggage compartment LHS trim. **Repeat applicable steps for the RHS luggage compartment trims.**
8. At the LHS exterior rear quarter underside of the vehicle, remove the vehicle grommet and drill the grommet hole out to Ø30mm. Ensure the interior area is clear of obstructions before drilling. **Note: If the vehicle grommet is occupied, drill into the sheet metal next to the grommet. Apply rust inhibitor after drilling.**
9. In the engine bay, route the power harness (P/No: 04825) from the battery area. Drop the harness down to the bottom where the LHS chassis is. Do not connect harness terminal to power at this point.
10. Continue routing the power harness along the LHS chassis (above the shroud), towards the rear of the vehicle. **Note: When routing any harnesses underneath the vehicle, ensure to avoid all moving parts, sources of heat and sharp objects.**
11. Pierce a hole or make an incision into the vehicle grommet and route the power harness through into the vehicle. Seal the cut hole with silicone after routing into place. Ensure there is enough slack for the harness 1-way connector to reach the trailer patch connection point (refer to Step 17).
12. Route the trailer patch (P/No: 101238-WL) terminals to the LHS tail light harness wires.
13. Following the table, connect the trailer patch ezy taps to the vehicle harness wires and then connect the trailer patch terminals to the corresponding wires:

Function	Trailer Patch	Vehicle Connector
L IND	GREEN / BLACK	BLUE / YELLOW
TAILS	BROWN / BLACK	BLUE / WHITE
BRAKES	RED / BLACK	BLUE
REVERSE	BLACK / WHITE	GREEN / RED

14. In the LHS interior rear quarter area beside the wheel arch, clean the inner sheet metal outer side with an alcohol wipe (not supplied).
15. Connect the 12-way trailer patch connector to the ECU and adhere the ECU to the cleaned area on the sheet metal. Ensure the ECU is mounted with the connector pointing downwards.

Wiring Loom Fitting Instructions To Suit Audi A3 MY15 Part Number 101238-WL

16. Secure the trailer patch WHITE wire ground terminal to the vehicle grounding point using the existing fastener.
17. Connect the 1-way power wire connector to the trailer harness 1-way mating connector.
18. Route the trailer patch RH branch across the rear of the vehicle and towards the vehicle RHS tail light harness.
19. At the RHS tail light area, following the table, connect the ezy tap to the vehicle harness wire and then connect the trailer harness terminal to the corresponding wire:

Function	Trailer Patch	Vehicle Connector
R IND	GREEN / BLACK	PURPLE / BROWN

20. At the rear exterior of the vehicle, mount the tail harness socket to the towbar mounting bracket using M4 fasteners (not supplied).
21. Route the tail harness (tail length: 1200mm) across the LHS and up into the drilled out hole. Adjust the trailer patch harness grommet so that it is seated correctly and cable tie (not supplied) in place.
22. In the engine bay, remove the fuse panel cover and connect the power harness orange wire ring terminal (1) to the indicated terminal (2).



23. Test the Trailer socket using a light board or multi-meter.
24. Secure the all harnesses using cables ties (not supplied).
25. Refit all removed parts and secure all fasteners.
26. Place instructions in glove box after fitment.



FITTING INSTRUCTIONS

Silent Anti-Rattle Hitch Pin (PR0001)

• These fitting instructions are supplied to ensure understanding of how the HITCH PIN should be fitted and used correctly.

• Once installed, we recommend **ALL** instructions are kept and placed in the vehicle glove box.

NOTE: Routine maintenance and inspection of the towbar & HITCH PIN is required. Regularly inspect for wear and check the tightness of the Hitch Pin. Follow instructions below to retighten the nut when necessary.

***Do not tow with your vehicle if the R CLIP or the HITCH PIN is loose or missing. Replacement parts are available from your Pro Series Distributor.**

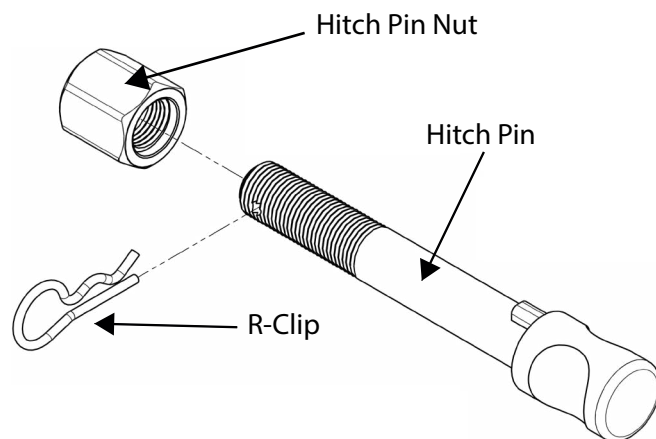

Fig 1. Silent Anti-Rattle Hitch Pin assembly

STEP 1

Insert Trailer Ball Mount (TBM) into towbar HITCHBOX, aligning hole in TBM SHANK with hole in HITCHBOX (Fig 2).

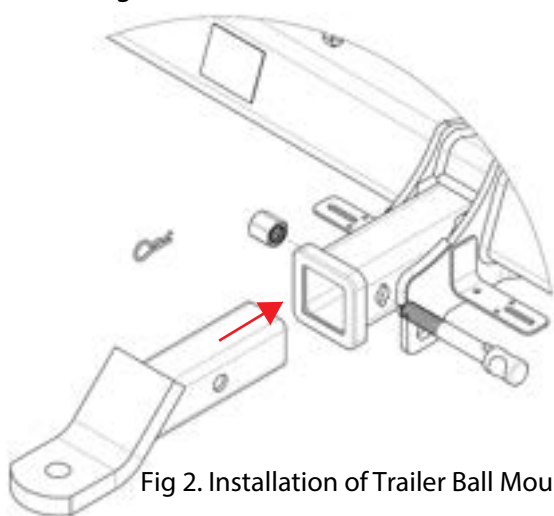

Fig 2. Installation of Trailer Ball Mount

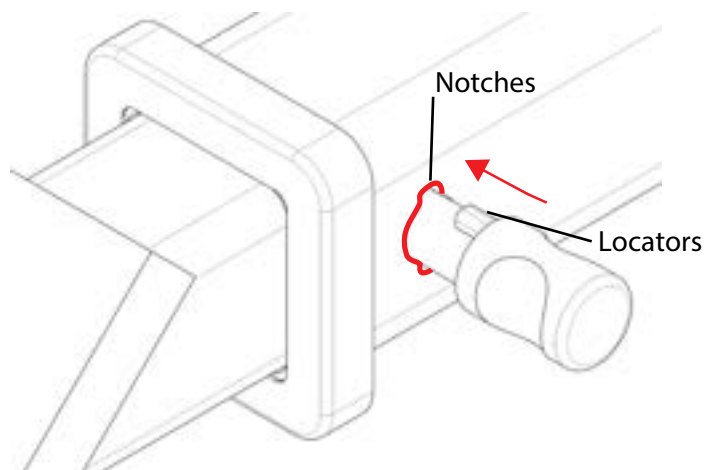

Fig 3. Silent Anti-Rattle Hitch Pin orientation

STEP 2

Insert HITCH PIN through hole in HITCHBOX and hole in TBM SHANK; ensure the LOCATORS are inserted into the NOTCHES in the HITCHBOX (Fig. 3).

STEP 3

Screw HITCH PIN NUT onto HITCH PIN; tighten HITCH PIN NUT until finger tight, ensuring TBM is restrained from movement.

STEP 4

Tighten HITCH PIN NUT by turning nut a further 1/8th of a turn in the clockwise direction using a 24mm spanner (Fig. 4).

STEP 5

Install HITCH PIN R CLIP through the hole on the HITCH PIN (Fig. 1).

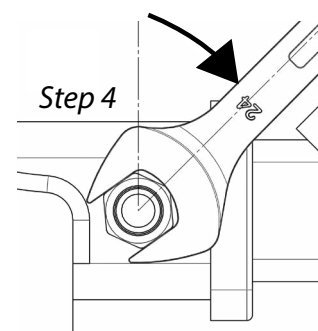

Fig 4. Tightening of Silent Anti-Rattle Hitch Pin Nut