

# TRAILBOSS

Tow bar Fitting Instructions  
To Suit BMW X3 4 DOOR WAGON 06-04-on  
Part Number QTBM111  
Rating 2000 kg Max Static Ball Load 158Kg

**WARNING:**

1. Do not, drill, cut, weld or otherwise modify the tow bar.
2. If you are using electric welding on a motor vehicle, **always** check that the vehicle is not equipped with electronic engine or instrument management equipment. Failure to do so could **destroy** any onboard computers. If in doubt, check with the vehicle's manufacturer.

**General:**

1. Ensure all hardware items have been included refer to assembly diagram.
2. It is recommended that the instructions are read through and completely understood before making any attempt to fit this product.
3. Be wary of any changes to vehicle designs or other accessories that may conflict with the installation of this product.
4. Before drilling ensure that the area is clear of fuel, electrical & other components.
5. All holes drilled into the body panels shall have all burrs & swarf removed then coated with a suitable rust preventative paint.
6. The high tensile fasteners supplied with this product were used to achieve the specified rating. If replacement is required ensure that fasteners of the same rating & quality are used. Contact an authorized **Trailboss** dealer if further information is required.
7. Ensure that all hardware is fastened to torque list below check fasteners on regular basis.
8. Tow bar load rating sticker provided with this product shall be conspicuously located on inside rear end of the driver's door. **(See diagram below).**
9. Trailboss recommends that you check your tow ball to ensure that it complies with the Australian standards **AS 4177.2**.
10. **PLEASE NOTE:** It is advised to remove your lug or tbm when not actually towing so as to produce a clear view of the vehicles registration plate if obscured, and to also provide maximum available departure angle

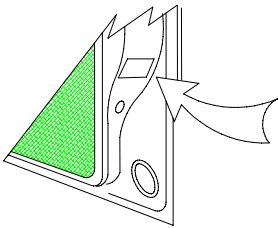

Place load rating sticker  
inside driver's door here

**FOR TOWING PURPOSES ONLY**  
For towing capacity details please refer to vehicle owner's manual or to the manufacturer. Overloading can void your warranties.

**RECOMMENDED ASSEMBLY TORQUE LISTING**  
Diameter Grade 8.8 Bolt

M6	9.5 Nm
M8	21.7 Nm
M10	43.4 Nm
M12	77.3Nm
M14	146 Nm
M16	189.8 Nm

**Tow bar Maintenance and Care.**

Trailboss recommends that bolt torque's, as listed below, are routinely and regularly inspected and checked for correct tension. Replace any worn or defective parts.

We recommended to remove Tow Ball Mounts (TBM's, tongues or lugs) when not being used for any considerable length of time.

So as to avoid injury, when not towing it is suggested that the tongue, Pull Pin and R-clip are removed then stored in a safe, clean and dry place, away from excessive moisture.

Hitch Pull Pins and spring "R" clips are regularly checked for proper installation. Replace any worn or defective parts.

Tow bar Fitting Instructions  
To Suit BMW X3 4 DOOR WAGON 06-04-on  
Part Number QTBM111

Rating 2000 kg Max Static Ball Load 158Kg

1. Remove bumper bar via
2. 4 x Scrivets and 2 x Screws on each mud flap
3. 1 x Torx head screw under inner guard in each wheel arch
4. 1 x Hex screw and 2 x Plastic nuts on bottom lip of bumper
5. 1 x Torx head screw under plastic covers on each side of tailgate opening see fig 1.
6. Remove and discard impact beam.
7. Fit tow bar to impact beam studs and fit hardware supplied fasten to torque listing.
8. Cut bumper push out window as per diagram see fig 3.
9. Cut bumper behind push out window following moulding as per diagram below see fig 2.
10. Refit bumper in reverse of step 2 and using new scrivets supplied for each mud flap.
11. Fit two halves of bumper push out window on each side of hitch box.
12. Drill 6mm hole in window halves so as to align with bumper tags on hitch box.
13. Attach windows halves to bumper tags with the two scrivets supplied.

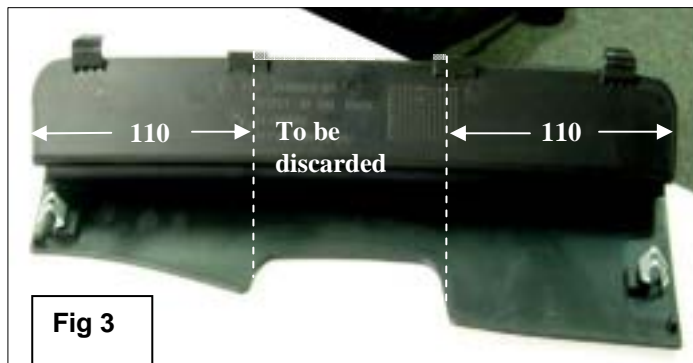
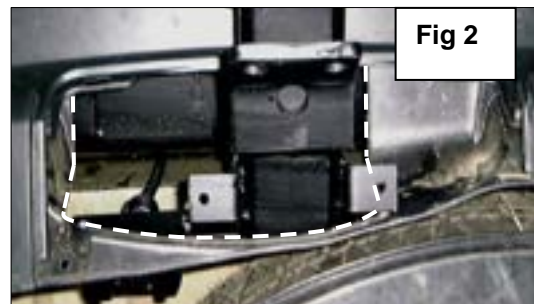

**This product is not recommended for the use of heavy duty weight distribution. This product has an inbuilt feature that will prevent the use of such devices. For further information contact year nearest Trailboss stockist.**

# TRAILBOSS

Tow bar Fitting Instructions  
 To Suit BMW X3 4 DOOR WAGON 06-04-on  
 Part Number QTBM111  
 Rating 2000 kg Max Static Ball Load 158Kg

Ensure that the vehicle owners manual or vehicle manufacturer is consulted for the correct towing capacity for each variant of the BMW X3 range.

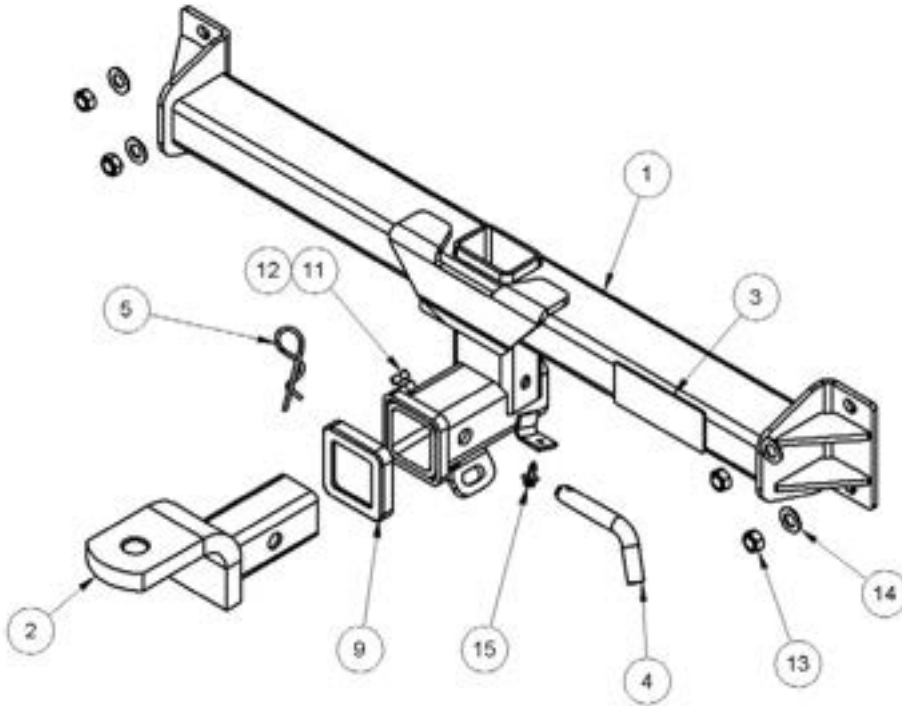

**NOTE: ITEMS 6, 7 & 8 ARE NOT SHOWN**

LOCATION	PART NO.	QTY.	DESCRIPTION	ITEM NO.
ASSEMBLY	QTBM111-A1	1	WELDED ASSEMBLY	1
ASSEMBLY	A21126	1	T.B.MOUNT	2
ASSEMBLY	96000	1	TRAILBOSS STICKER	3
ASSEMBLY	8002	1	PULL PIN	4
ASSEMBLY	8003	1	CLIP ( SPRING COTTER PIN )	5
BOLT PACK	B02537R	1	ASSEMBLY BOLT PACK	6
BOLT PACK	94062	1	BOLT BAG	7
BOLT PACK	QTBM111-FI	1	FITTING INSTRUCTIONS	8
BOLT PACK	COL_04	1	HITCH BOX COLLAR COVER	9
BOLT PACK	X2000-158A	1	DOOR RATING STICKER	10
BOLT PACK	92040	1	M10 X 20 BOLT	11
BOLT PACK	92310	1	NUT M10 x 1.5P	12
BOLT PACK	92318	4	NUT M12 NYLOC	13
BOLT PACK	92338	4	Wshr ft 1/2" x 1-1/8" x 16 z/p	14
BOLT PACK	40157	10	SCRIVET CFZ-020-0034	15