

TRAILBOSS

Towbar Fitting Instructions To Suit BMW X5 Part Number QTBM114L Rating 2700/270 kg

PLACE THESE INSTRUCTIONS IN THE VEHICLE'S GLOVEBOX AFTER INSTALLATION IS COMPLETED

WARNING:

1. Do not, drill, cut, weld or otherwise modify the tow bar.
2. If you are using electric welding on a motor vehicle, **always** check that the vehicle is not equipped with electronic engine or instrument management equipment. Failure to do so could **destroy** any onboard computers. If in doubt, check with the vehicle's manufacturer.
3. The high tensile fasteners supplied with this product were used to achieve the specified rating. If replacement is required ensure that fasteners of the same rating & quality are used. Contact an authorised **Trailboss** dealer if further information is required.

General:

1. Ensure all hardware items have been included refer to assembly diagram.
2. It is recommended that the instructions are read through and completely understood before making any attempt to fit this product.
3. Be wary of any changes to vehicle designs or other accessories that may conflict with the installation of this product.
4. Before drilling ensure that the area is clear of fuel, electrical & other components.
5. All holes drilled into the body panels shall have all burrs & swarf removed then coated with a suitable rust preventative paint.
6. For vehicles that require the bumper to be cut. Ensure cut out area is in correct position on the vehicle prior to cutting the bumper.
7. The high tensile fasteners supplied with this product were used to achieve the specified rating. If replacement is required ensure that fasteners of the same rating & quality are used. Contact an authorized **Trailboss** dealer if further information is required.
8. Ensure that all hardware is fastened to torque list below check fasteners on regular basis.
9. Tow bar load rating sticker provided with this product shall be conspicuously located on inside rear end of the driver's door. **(See diagram below).**
10. Trailboss recommends that you check your tow ball to ensure that it complies with the Australian standards **AS 4177.2.**
11. **PLEASE NOTE:** It is advised to remove your lug or tbn when not actually towing so as to produce a clear view of the vehicles registration plate if obscured, and to also provide maximum available departure angle
12. Pull Pin must be fit in down position.

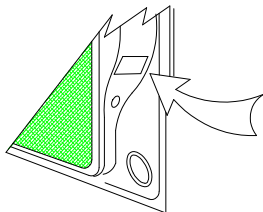

Place load rating sticker
inside driver's door here

FOR TRAILER TOWING PURPOSES ONLY
For towing capacity details please refer to vehicle owner's manual or to the manufacturer. Overloading can void your warranties.

RECOMMENDED ASSEMBLY TORQUE LISTING

<u>Diameter</u>	<u>Grade 8.8 Bolt</u>
M6	9.5 Nm
M8	21.7 Nm
M10	43.4 Nm
M12	77.3Nm
M14	146 Nm
M16	189.8 Nm

Tow bar Maintenance and Care.

Trailboss recommends that bolt torque's, as listed below, are routinely and regularly inspected and checked for correct tension. Replace any worn or defective parts.

We recommended to remove Tow Ball Mounts (TBM's, tongues or lugs) when not being used for any considerable length of time.

So as to avoid injury, when not towing it is suggested that the tongue, Pull Pin and R-clip are removed then stored in a safe, clean and dry place, away from excessive moisture.

Hitch Pull Pins and spring "R" clips are regularly checked for proper installation. Replace any worn or defective parts.



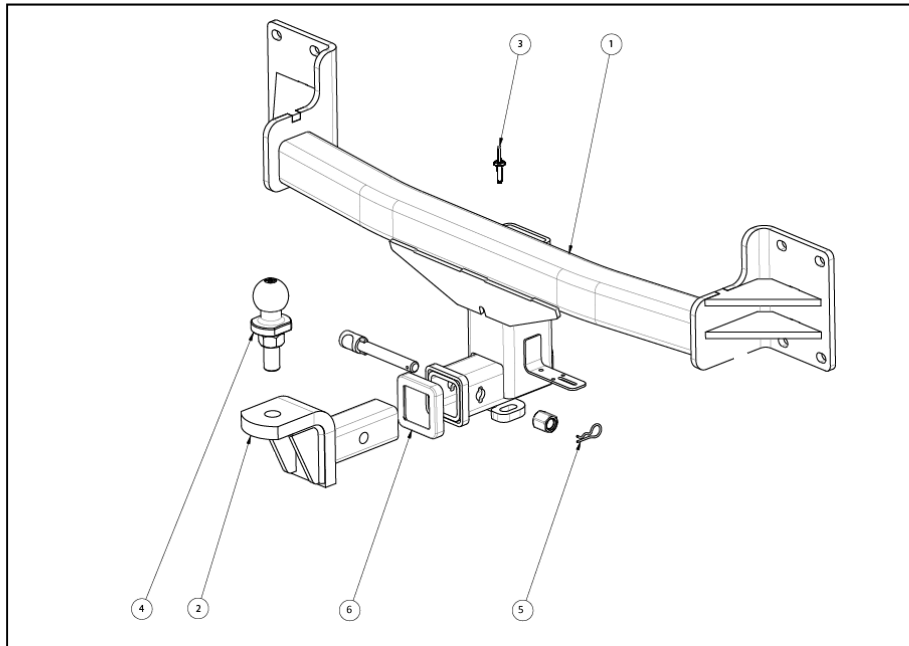

Towbar Fitting Instructions
 To Suit BMW X5
 Part Number QTBM114L
 Rating 2700/270 kg

PLACE THESE INSTRUCTIONS IN THE VEHICLE'S GLOVEBOX AFTER INSTALLATION IS COMPLETED





QTY.	DESCRIPTION	ITEM NO.
1	WELDED BMW X5 TB ASSY	1
1	CL4 TBM	2
12	POP RIVET	3
1	TOWBALL	4
1	ANTI-RATTLE PULL PIN ASSY	5
1	HITCH BOX COLLAR COVER	6

ADDITIONAL ITEMS

WIRING LOOM FITTING INSTRUCTION

D SHACKLES LR LABEL



Towbar Fitting Instructions
To Suit BMW X5
Part Number QTBM114L
Rating 2700/270 kg

PLACE THESE INSTRUCTIONS IN THE VEHICLE'S GLOVEBOX AFTER INSTALLATION IS COMPLETED

INSTRUCTION:

1. Remove 6 screws from under the bumper.
2. Remove 3 plastic rivets under rear wheel arch on the RHS by pushing in the centre pin.
Repeat for LHS.
3. Lift open wheel flare guard then remove 1 screw holding the bumper behind the flare guard.
Repeat for LHS.
4. Remove rear reflector on the bumper facia on the RHS to expose the screw.
Remove the screw.
Repeat for LHS.
5. Open tailgate and remove 2 flange nuts securing the RHS taillight to the vehicle. Disconnect the connector and remove the taillight assembly.
Repeat for LHS.
6. Remove screw located in taillight bumper cavity.
Repeat for LHS.
7. Remove bumper from the car. Ensure any wiring is disconnected.
Remove 8 Nuts holding impact beam and retain nuts for reuse.
Discard impact beam.
8. Fit Towbar into impact beam mounting points, secure with nuts retained from impact beam.
Torque all nuts to specifications.
9. If the vehicle is F15 refit the bumper and wheel flares using plastic rivets provided.
10. If the vehicle is E70, a bumper cut is required; 100mm wide by 90 mm deep section from centre bottom of bumper.
Refit bumper and wheel flares using plastic rivet provided.



Wiring Loom Fitting Instructions
To Suit BMW X5 & X6, X6 MY15
Part Number 100707-WL

Wiring Loom Installation Instructions

BMW X5, X6 & X6 MY15
Part No: 100707-WL

ECU Required: 04829
Tail Harness Length Required: 1800mm

Wiring Loom Installation Time: Approx 30 Mins

TRAILBOSS

Wiring Loom Fitting Instructions To Suit BMW X5 & X6, X6 MY15 Part Number 100707-WL

1. Remove the floor carpet cover.
2. Remove the LHS & RHS access panel covers.
3. Remove the tool storage tray by first removing the fasteners.
4. Remove the LHS storage compartment.
5. Remove the RHS storage compartment.

This Step for BMW X6 MY15 models only:

6. In the RHS of the luggage compartment area, drill out a Ø30mm hole (1) into the vehicle sheet metal. File down any rough or sharp edges and apply rust inhibitor (not supplied).



This Step for all models except BMW X6 MY15:

7. In the RHS of the luggage compartment, lift up the carpet cover and remove the vehicle grommet (1).
8. From the outside of the vehicle, drill out the grommet hole (1) to Ø30mm. File any rough or sharp edges and apply rust inhibitor, after drilling.

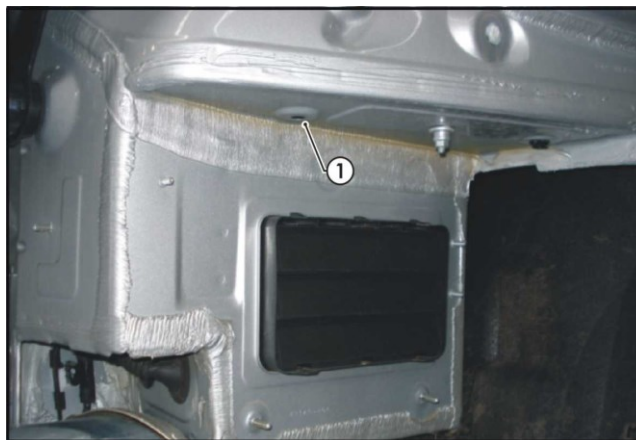



Wiring Loom Fitting Instructions
To Suit BMW X5 & X6, X6 MY15
Part Number 100707-WL

9. **Always use a multi-meter to confirm wire colours.** Connect the ezy tap to the vehicle harness wire and then connect the trailer harness terminal to the corresponding wire.

For X6 pre-MY15 models:

Function	Trailer Patch	Vehicle Connector
L.IND	YELLOW / BLACK	BLUE / BROWN

For X5 MY10 models:

Function	Trailer Patch	Vehicle Connector
L.IND	YELLOW / BLACK	GREEN / BLUE

For X5 MY13 and X6 MY15 models:

Function	Trailer Patch	Vehicle Connector
L.IND	YELLOW / BLACK	BLACK / WHITE

10. Route the trailer harness (P/No: 100707-WL) along the vehicle harness along the rear of the vehicle and towards the RHS tail light connector.

This Step for BMW X5 and X6 pre-MY15 only:

11. Connect the trailer harness ground ring terminal to the existing vehicle grounding point located at the centre rear of the vehicle.

Refer to the following steps for applicable model variation wire colours (always use a multi-meter to confirm colours):

For BMW X5 MY10 models:

12. Following the table below, connect the ezy taps to the vehicle harness wires and then connect the trailer harness terminals to the corresponding wires. Go to Step 15.

Function	Trailer Patch	Vehicle Connector
R.IND	GREEN / BLACK	BLUE / BROWN
REVERSE	BLACK / WHITE	BLACK / YELLOW
TAIL	BROWN / BLACK	YELLOW / PURPLE
BRAKES	RED / BLACK	BLACK / BLUE

For BMW X6 MY15 models:

13. Following the table below, connect the ezy taps to the vehicle harness wires and then connect the trailer harness terminals to the corresponding wires. Go to Step 15.

Function	Trailer Patch	Vehicle Connector
R.IND	GREEN / BLACK	BLACK / WHITE
REVERSE	BLACK / WHITE	YELLOW / BLACK
TAIL	BROWN / BLACK	GREEN / YELLOW
BRAKES	RED / BLACK	BLACK / BLUE

TRAILBOSS

Wiring Loom Fitting Instructions To Suit BMW X5 & X6, X6 MY15 Part Number 100707-WL

For all other models:

- Following the table below, connect the ezy taps to the vehicle harness wires and then connect the trailer harness terminals to the corresponding wires. Go to Step 15.

Function	Trailer Patch	Vehicle Connector
R.IND	BLACK / GREY	BLUE / BROWN
REVERSE	GREY / YELLOW	BLACK / YELLOW
TAIL	BLACK / BLUE	YELLOW / PURPLE
BRAKES	WHITE / BLACK	BLACK / WHITE

- Remove the existing vehicle 30-amp fuse (1).
- Slot the supplied 20-amp fuse (2) into the upper slot of the add-a-fuse harness (3).
- Slot the existing vehicle 30-amp fuse (1) into the lower slot of the add-a-fuse harness (3).
- Connect the add-a-fuse harness to the mating Trailer Patch Harness connector (4).
- Insert the add-a-fuse harness fuse connector (5) into the vacant slot, with the orientation of the fuses pointing down.

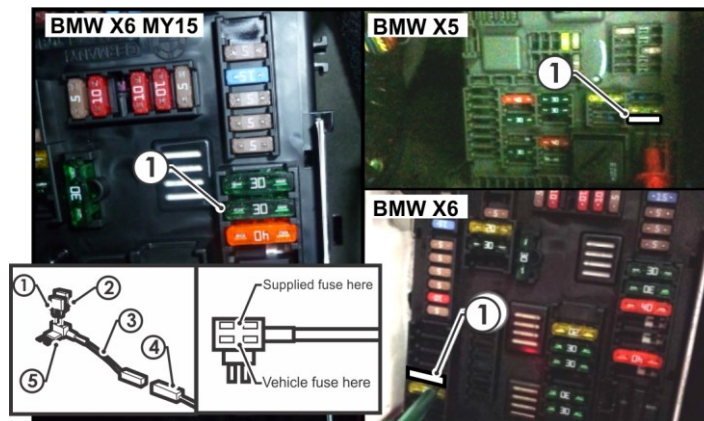

TRAILBOSS

Wiring Loom Fitting Instructions To Suit BMW X5 & X6, X6 MY15 Part Number 100707-WL

This Step for BMW X6 MY15 only:

20. In the RHS rear quarter next to the fuses, secure the vehicle ground ring terminal to the vehicle grounding point using the existing grounding fastener.
21. Connect the trailer harness 12-way connector to the ECU (P/No: 04829).
22. Slot the ECU (1) into the vacant slot underneath the fuse panel.

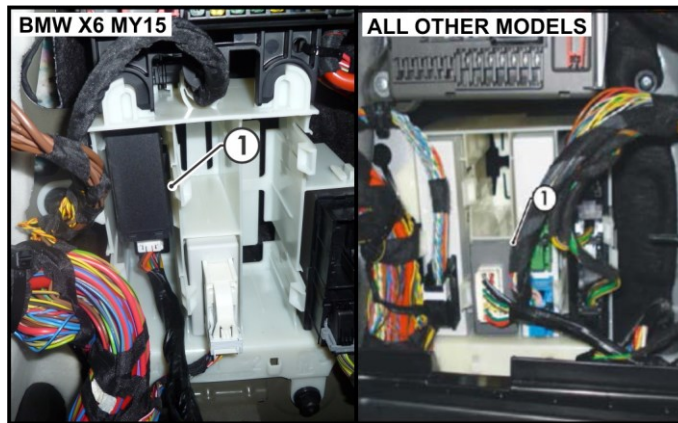

23. Connect the trailer harness 8-way connector to the tail harness (tail length 1800mm) mating connector.
24. Route the tail harness through the previously drilled out grommet hole and towards the towbar.
25. Mount the trailer socket to the towbar mounting bracket using M4 fasteners (not supplied).
26. Ensure the tail harness grommet is seated correctly and secured in place using a cable tie (not supplied).
27. Test the Trailer Harness function using a light board or multi-meter.
28. Secure all harnesses using cables ties (not supplied).
29. Re-fit all removed parts and secure all fasteners, ensuring there are no squeaks or rattles.
30. Place the instructions in the glove box after fitment.



FITTING INSTRUCTIONS

Silent Anti-Rattle Hitch Pin (PR0001)

• These fitting instructions are supplied to ensure understanding of how the HITCH PIN should be fitted and used correctly.

• Once installed, we recommend **ALL** instructions are kept and placed in the vehicle glove box.

NOTE: Routine maintenance and inspection of the towbar & HITCH PIN is required. Regularly inspect for wear and check the tightness of the Hitch Pin. Follow instructions below to retighten the nut when necessary.

***Do not tow with your vehicle if the R CLIP or the HITCH PIN is loose or missing. Replacement parts are available from your Pro Series Distributor.**

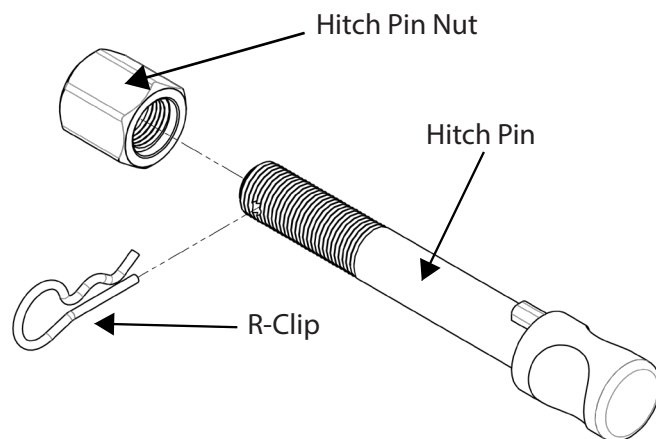

Fig 1. Silent Anti-Rattle Hitch Pin assembly

STEP 1

Insert Trailer Ball Mount (TBM) into towbar HITCHBOX, aligning hole in TBM SHANK with hole in HITCHBOX (Fig 2).

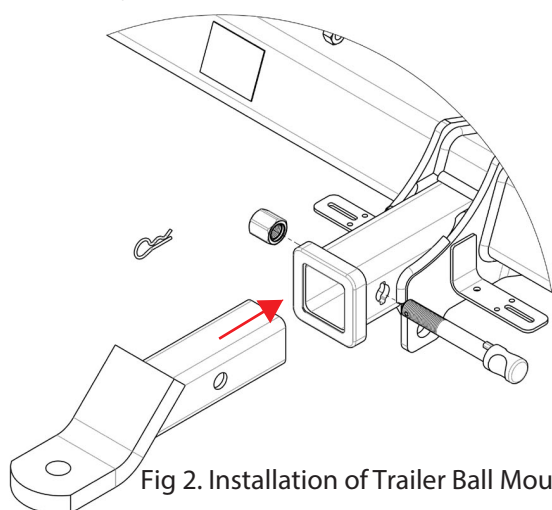

Fig 2. Installation of Trailer Ball Mount

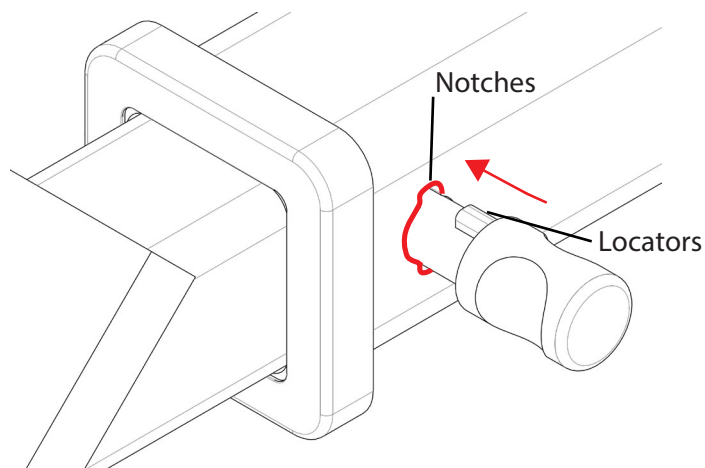

Fig 3. Silent Anti-Rattle Hitch Pin orientation

STEP 2

Insert HITCH PIN through hole in HITCHBOX and hole in TBM SHANK; ensure the LOCATORS are inserted into the NOTCHES in the HITCHBOX (Fig. 3).

STEP 3

Screw HITCH PIN NUT onto HITCH PIN; tighten HITCH PIN NUT until finger tight, ensuring TBM is restrained from movement.

STEP 4

Tighten HITCH PIN NUT by turning nut a further 1/8th of a turn in the clockwise direction using a 24mm spanner (Fig. 4).

STEP 5

Install HITCH PIN R CLIP through the hole on the HITCH PIN (Fig. 1).

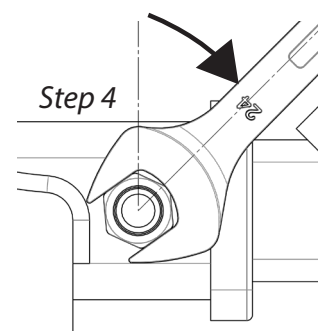

Fig 4. Tightening of Silent Anti-Rattle Hitch Pin Nut