

TRAILBOSS

Towbar Fitting Instructions
To Suit CHRYSLER VOYAGER STOW N GO 11/2004-ON
Part Number QTCH101
Rating 1600Kg

*Max. Towing Weight: 1600Kg
Max. Ball Weight: 80kg*

1. Ensure all hardware items have been included.
2. Remove rear bumper by removing 4 plastic screws and 8 Phillips headed screws from the underside of the bumper
3. Remove rear impact beam by removing the rear mounting bolts from the underside of the sub-frame rails, and discard the mounting bolts and impact beam.
4. Offer towbar up to vehicle, ensuring that the side mounts line up with the holes in the sub-frame rails, and fasten using the supplied M10X30 bolts, flat washers, and spring washers.
5. Tighten all bolts to torque listing.
6. Cut bumper relief as per Figures 2 and 3
7. Reassemble in the reverse of Step 2.
8. Towbar rating sticker to be conspicuously located on inside rear end of the driver's door, see diagram below.

RECOMMENDED ASSEMBLY TORQUE LISTING

Diameter Grade 8.8 Bolt

	Nm
M6	9.5
M8	21.7
M10	43.4
M12	77.3
M16	189.8

FOR TOWING PURPOSES ONLY
For towing capacity details please refer to vehicle owner's manual or to the manufacturer. Overloading can void your warranties.

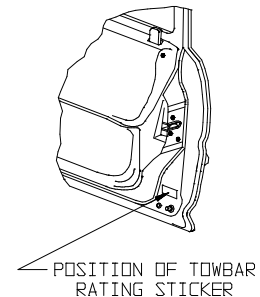

TRAILBOSS

Towbar Fitting Instructions
To Suit CHRYSLER VOYAGER STOW N GO 11/2004-ON
Part Number QTCH101
Rating 1600Kg

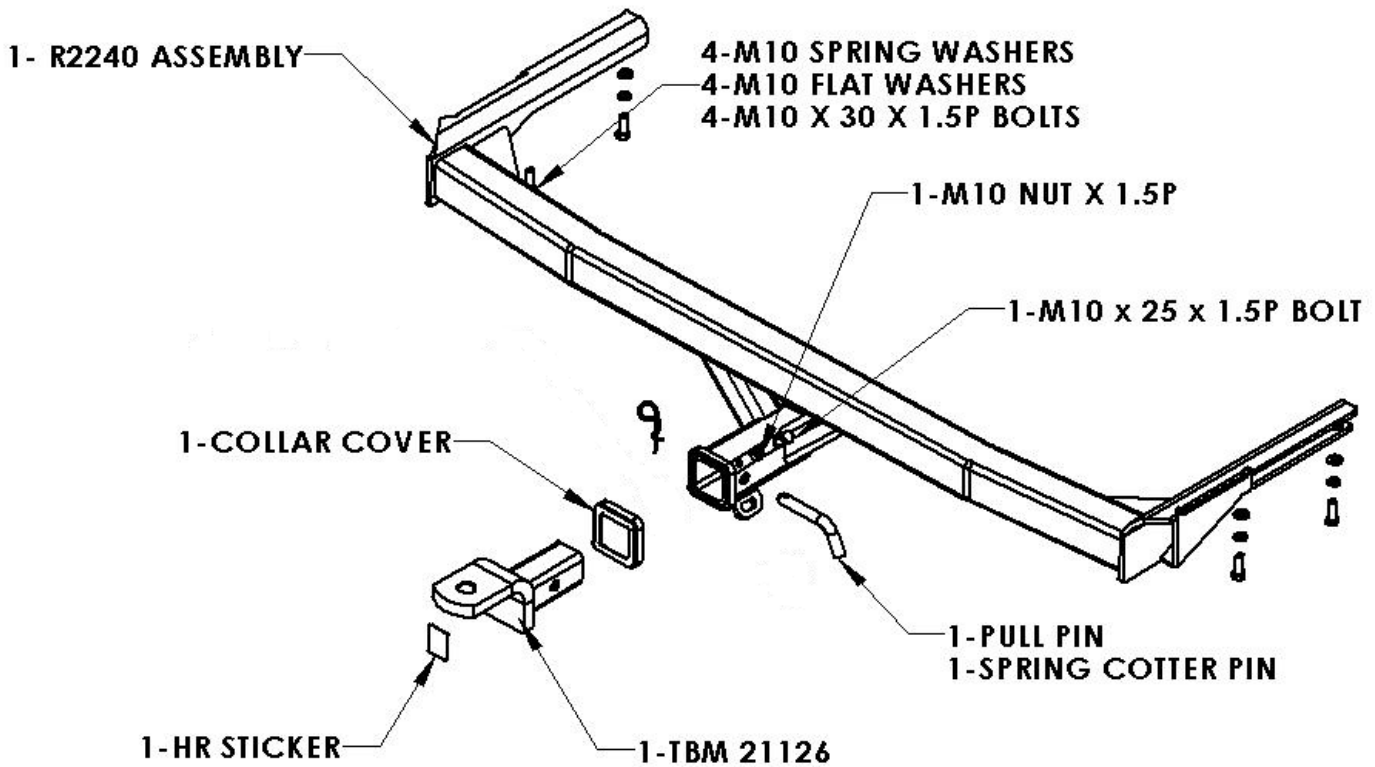
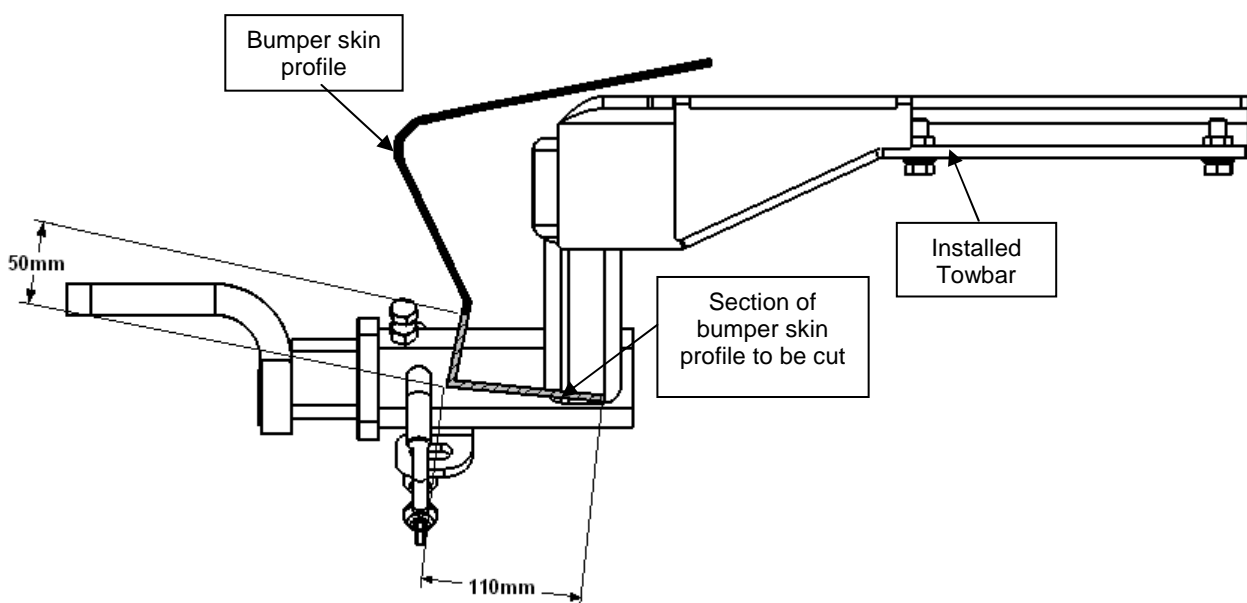

Figure-1 Final Towbar assembly



Towbar Fitting Instructions
To Suit CHRYSLER VOYAGER STOW N GO 11/2004-ON
Part Number QTCH101
Rating 1600Kg

Figure-2 Profile view of bumper cut. Note all dimension are in mm

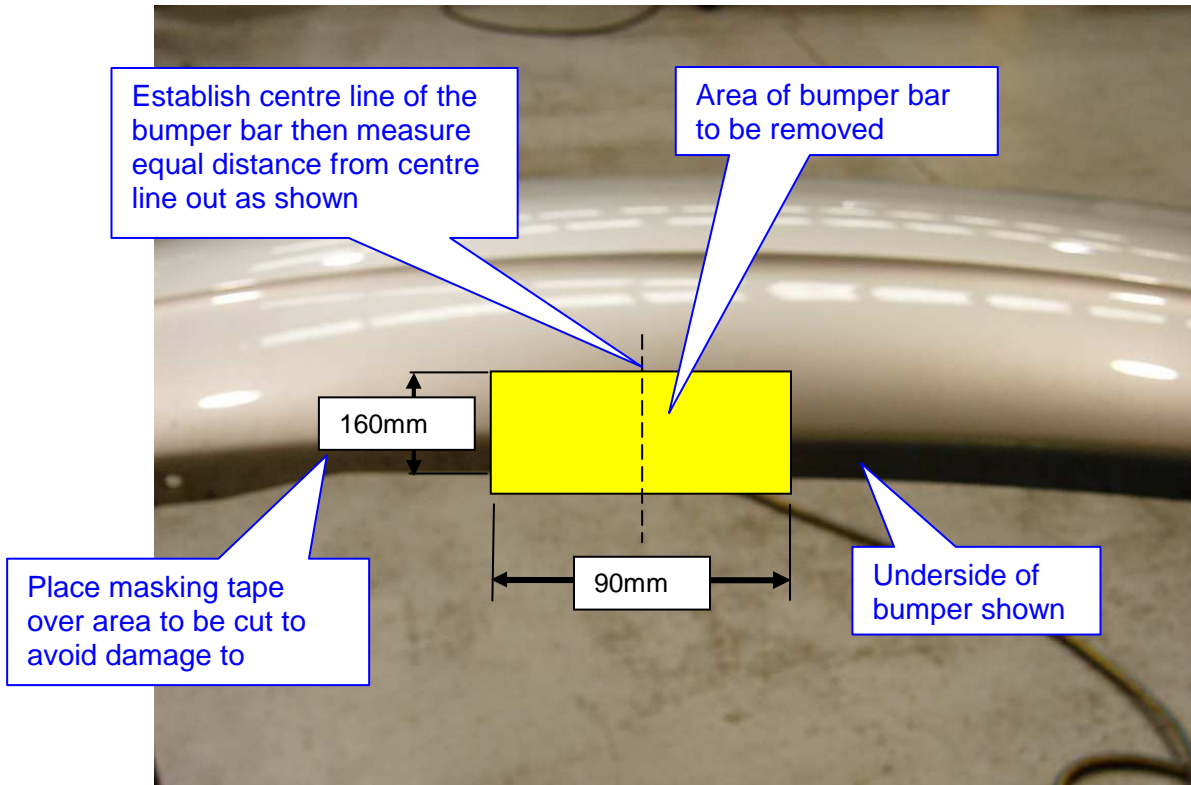

Figure-3 Front view of bumper cut