

TRAILBOSS

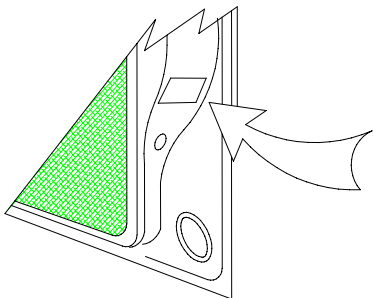
Tow bar Fitting Instructions To Suit Mitsubishi Triton GLX, GLXR & GLS With Factory Step Fitted 07-06-on Part Number QTCL375L Rating 2500/250 kg

WARNING:

1. Do not, drill, cut, weld or otherwise modify the tow bar.
2. If you are using electric welding on a motor vehicle, **always** check that the vehicle is not equipped with electronic engine or instrument management equipment. Failure to do so could **destroy** any onboard computers. If in doubt, check with the vehicle's manufacturer.

General:

1. Ensure all hardware items have been included
2. It is recommended that the instructions are read through and completely understood before making any attempt to fit this product.
3. Be wary of any changes to vehicle designs or other accessories that may conflict with the installation of this product.
4. Before drilling ensure that the area is clear of fuel, electrical & other components.
5. All holes drilled into the body panels shall have all burrs & swarf removed then coated with a suitable rust preventative paint.
6. The high tensile fasteners supplied with this product were used to achieve the specified rating. If replacement is required ensure that fasteners of the same rating & quality are used. Contact an authorized **Trailboss** dealer if further information is required.
7. Ensure that all hardware is fastened to torque list below check fasteners on regular basis.
8. Tow bar load rating sticker provided with this product shall be conspicuously located on inside rear end of the driver's door. **(See diagram below).**
9. Trailboss recommends that you check your tow ball to ensure that it complies with the Australian standards **AS 4177.2**.
10. **PLEASE NOTE:** It is advised to remove your lug or tbn when not actually towing so as to produce a clear view of the vehicles registration plate if obscured, and to also provide maximum available departure angle.



Place load rating sticker
inside driver's door here

RECOMMENDED ASSEMBLY TORQUE LISTING

Diameter Grade 8.8 Bolt

M6	9.5 Nm
M8	21.7 Nm
M10	43.4 Nm
M12	77.3 Nm
M16	189.8 Nm

ENSURE THAT SPRING WASHERS PROVIDED ARE USED WITH ALL FASTENERS.

FOR TOWING PURPOSES ONLY

For towing capacity details please refer to vehicle owner's manual or to the vehicle manufacturer overloading can void your warranties.

TRAILBOSS

Tow bar Fitting Instructions To Suit Mitsubishi Triton GLX, GLXR & GLS With Factory Step Fitted 07-06-on Part Number QTCL375L Rating 2500/250 kg

Removal of factory rear step

1. This product requires the rear step to be removed then reinstalled.
2. Remove the original factory step via
 - a. 2 X M 12 nuts each side of the chassis rails see fig 1.
 - b. 2 X M 8 bolts each side of the chassis rails see fig 1, retain M8 bolts to refit the step after tow bar installation.
 - c. Remove mounting insert from inside the chassis rails each side see fig 2 then discard.
 - d. Discard the step mounting brackets each side see fig 1.

Fig 1

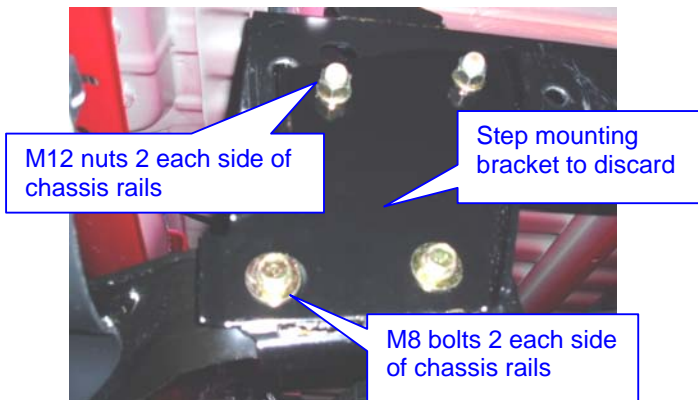
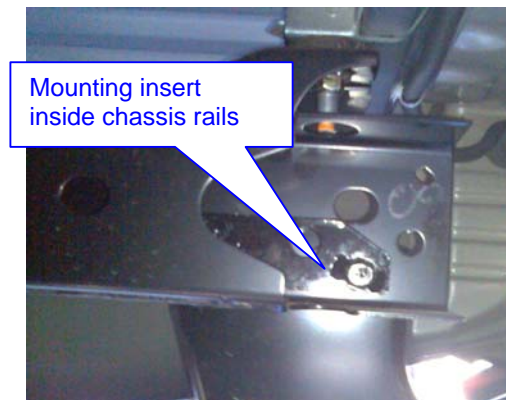


Fig 2

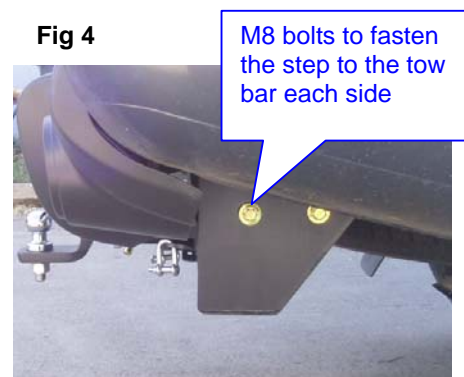


3. Hold the rear step firmly then pull down & rearward to avoid hitting the rear underside of the tub body then remove brackets from step.
4. Offer tow bar to the chassis rails so the holes in the side plates align with the holes in the chassis rails.
5. Fasten loosely with supplied hardware as per diagram below.
6. Then ensure that all hardware is fastened to the torque listing on the page 1.
7. Offer rear step to the mounting points located on the side arms for the tow bar se fig 3.
8. Ensure that the step is straight to the rear off the vehicle before fastening.
9. Then fasten with original M8 bolts retained in step No 2 b see fig 4.

Fig 3

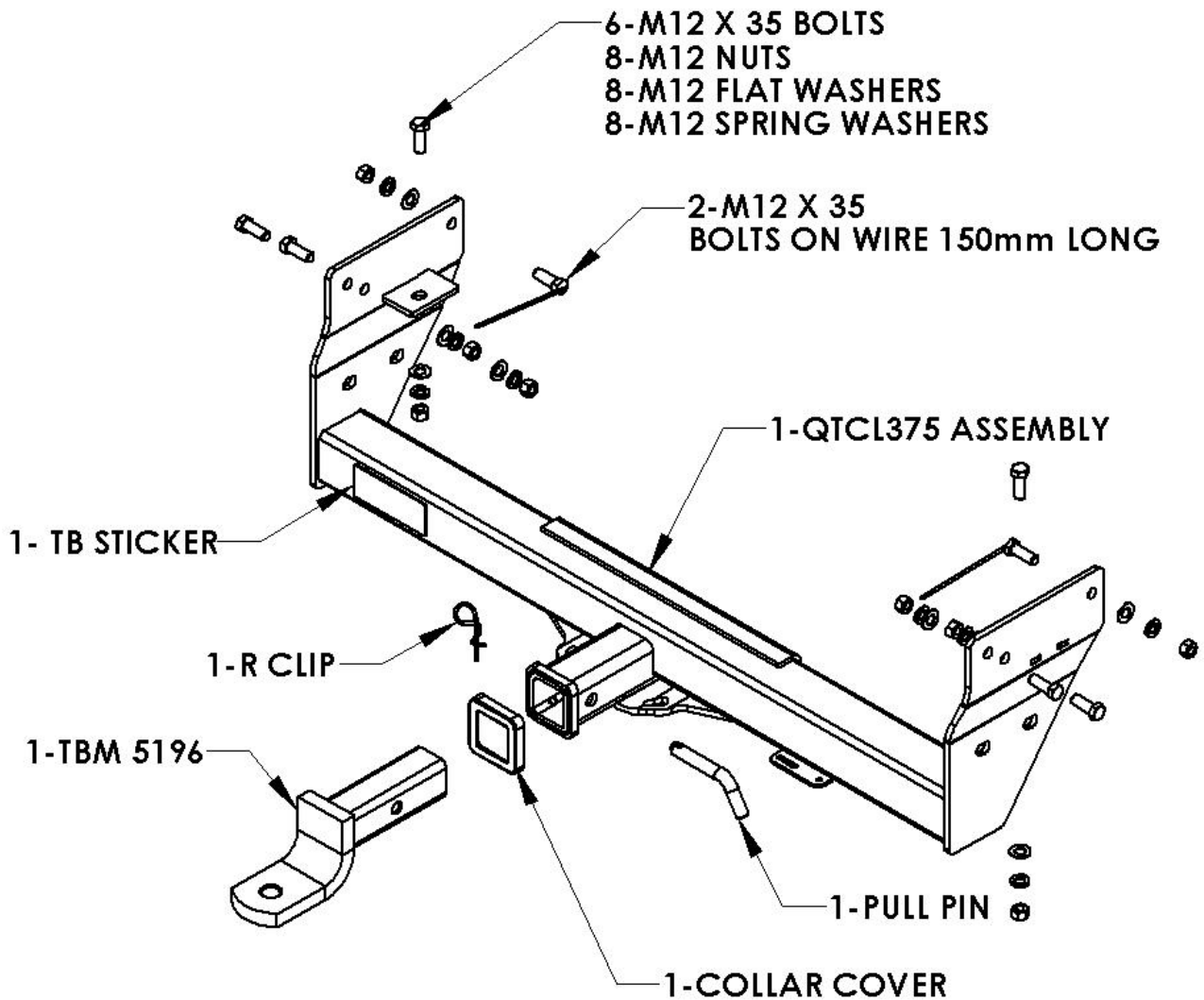


Fig 4



TRAILBOSS

Tow bar Fitting Instructions
To Suit Mitsubishi Triton GLX, GLXR & GLS With Factory Step Fitted 07-06-on
Part Number QTCL375L
Rating 2500/250 kg





Wiring Loom Fitting Instructions
To Suit Mitsubishi Triton
Part Number 100006-WL

Wiring Loom Installation Instructions

Mitsubishi Triton
Part No: 100006-WL

Tail Harness Length Require: 1200mm

Wiring Loom Installation Time: Approx 30 Mins



Wiring Loom Fitting Instructions
To Suit Mitsubishi Triton
Part Number 100006-WL

1. Underneath the rear LHS quarter of the vehicle, disconnect the LHS tail light connector.
2. Connect the Trailer Patch Harness connectors (P/No: 100006-WL) in between the tail light connectors.
3. Connect the relays to the Trailer Patch Harness and mount onto the chassis rail. Secure the relays onto the chassis rail using M6 nuts and bolts.
4. Add green secondary lock so that the connectors cannot come out.
5. On the Tail Harness (tail length 1200mm) and mating connector, apply electrical grease or silicon on to the back of the connectors to make them water proof.
6. Connect the Tail Harness to the Trailer Patch Harness.
7. Drill a Ø6mm hole into the chassis rail at a location where the Trailer Patch ground ring terminal can reach and secure the Trailer Patch ground ring terminal with a nut and bolt ensuring the ring terminal is grounded properly.
8. Route the Trailer Patch Harness battery ring terminal wire along the LHS chassis rail following the vehicle body harness, all the way to the engine bay.
9. Secure with cable ties at every 200mm intervals.
10. In the engine bay, retrieve the Trailer Harness battery ring terminal wire.
11. Secure the Trailer Harness battery ring terminal onto the positive battery terminal.
12. Secure the Tail Harness socket onto the trailer socket mounting place using M4 fasteners.
13. Test the Trailer socket using a light board or multimeter.
14. Secure the all harnesses using cables ties.
15. Refit all removed parts and secure all fasteners.
16. Place instructions in glove box after fitment.