

TRAILBOSS

Towbar Fitting Instructions To Suit MITSUBISHI PAJERO SEDAN 5/2000 to 10-2006 Part Number QTCL491 Rating 2500Kg

1. Ensure all hardware items have been included.
2. Remove tie down bumper support frame (4x12 bolts per side and 4 – M6 bolts holding plastic bumper, where fitted and retain bolts).
3. Cut bumper using sketches provided
4. Fit towbar so as to align with tie down bumper support frame captive nuts and refit frame bolts to original positions.
5. Fit 32x40x10 1.25 tapped plates and wire supplied and original bolt on upper driver and passenger side.
6. Tighten vertical bolts first to torque listings then horizontal.
7. Fit 6mm clip nuts to mounting tabs on towbar and refit two original bolts, where fitted.

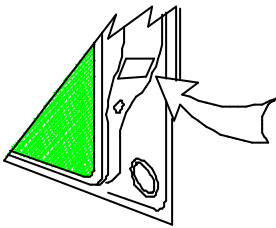

Place load rating sticker
inside driver's door here

FOR TOWING PURPOSES ONLY

For towing capacity details please refer to vehicle owner's manual or to the manufacturer. Overloading can void your warranties.

RECOMMENDED ASSEMBLY TORQUE LISTING

Diameter	Grade 8.8 Bolt
M6	9.5 Nm
M8	21.7 Nm
M10	43.4 Nm
M12	77.3 Nm
M16	190.0 Nm

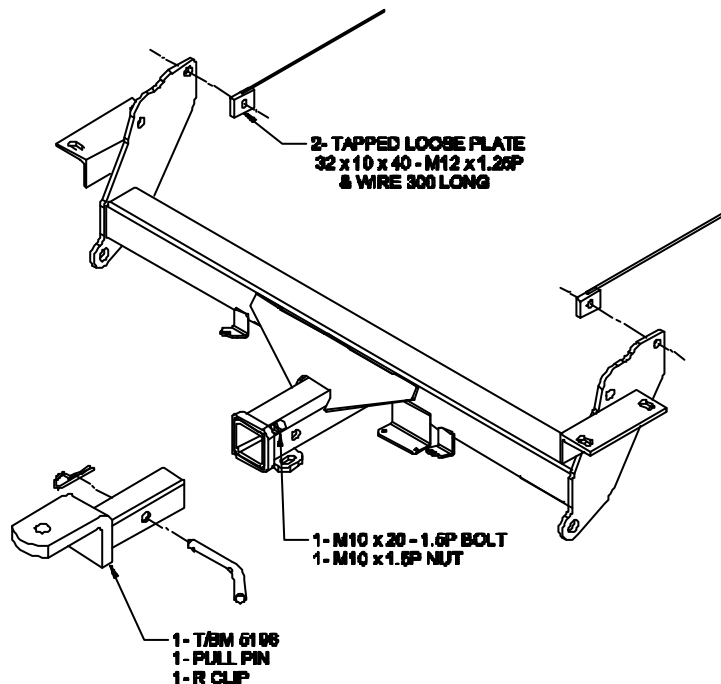

Towbar Fitting Instructions
To Suit MITSUBISHI PAJERO SEDAN 5/2000 to 10-2006
Part Number QTCL491
Rating 2500Kg

10/02 – ON
N/P MODEL

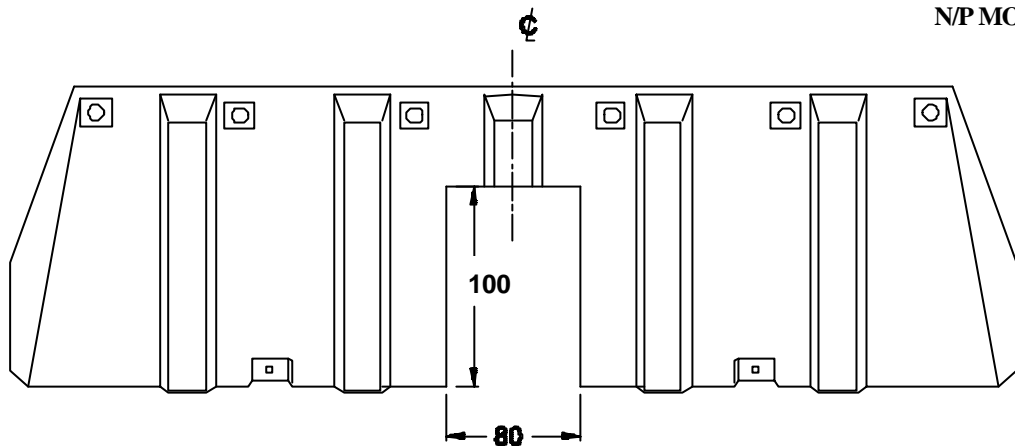

**BUMPER SKIRT CUT OUT
INSIDE VIEW**

5/00 – 12/02

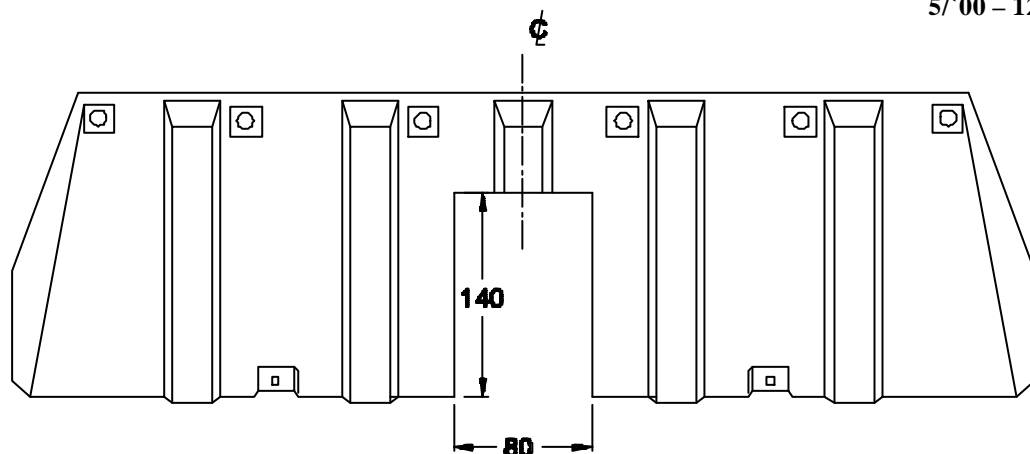

**BUMPER SKIRT CUT OUT
INSIDE VIEW**