

TRAILBOSS

Tow bar Fitting Instructions To Suit Mitsubishi Pajero NS Wagon LWB & SWB 11-2006-on Part Number QTCL492L Rating 3000 kg

WARNING:

1. Do not, drill, cut, weld or otherwise modify the tow bar.
2. If you are using electric welding on a motor vehicle, **always** check that the vehicle is not equipped with electronic engine or instrument management equipment. Failure to do so could **destroy** any onboard computers. If in doubt, check with the vehicle's manufacturer.

General:

1. Ensure all hardware items have been included
2. It is recommended that the instructions are read through and completely understood before making any attempt to fit this product.
3. Be wary of any changes to vehicle designs or other accessories that may conflict with the installation of this product.
4. Before drilling ensure that the area is clear of fuel, electrical & other components.
5. All holes drilled into the body panels shall have all burrs & swarf removed then coated with a suitable rust preventative paint.
6. The high tensile fasteners supplied with this product were used to achieve the specified rating. If replacement is required ensure that fasteners of the same rating & quality are used. Contact an authorized **Trailboss** dealer if further information is required.
7. Ensure that all hardware is fastened to torque list below check fasteners on regular basis.
8. Tow bar load rating sticker provided with this product shall be conspicuously located on inside rear end of the driver's door. **(See diagram below).**
9. Trailboss recommends that you check your tow ball to ensure that it complies with the Australian standards **AS 4177.2**.
10. **PLEASE NOTE:** It is advised to remove your lug or tbn when not actually towing so as to produce a clear view of the vehicles registration plate if obscured, and to also provide maximum available departure angle

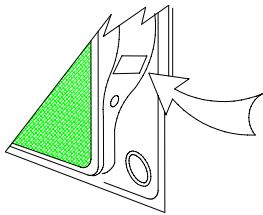

Place load rating sticker
inside driver's door here

FOR TOWING PURPOSES ONLY

For towing capacity details please refer to vehicle owner's manual or to the manufacturer. Overloading can void your warranties.

RECOMMENDED ASSEMBLY TORQUE LISTING

Diameter Grade 8.8 Bolt

M6	9.5 Nm
M8	21.7 Nm
M10	43.4 Nm
M12	77.3 Nm
M16	189.8 Nm

Tow bar Maintenance and Care.

Trailboss recommends that bolt torque's, as listed below, are routinely and regularly inspected and checked for correct tension. Replace any worn or defective parts.

We recommended to remove Tow Ball Mounts (TBM's, tongues or lugs) when not being used for any considerable length of time.

So as to avoid injury, when not towing it is suggested that the tongue, Pull Pin and R-clip are removed then stored in a safe, clean and dry place, away from excessive moisture.

Hitch Pull Pins and spring "R" clips are regularly checked for proper installation. Replace any worn or defective parts.

Tow bar Fitting Instructions To Suit Mitsubishi Pajero NS Wagon LWB & SWB 11-2006-on Part Number QTCL492L Rating 3000 kg

11. Remove tie down support frame via
 - a. 4 x M12 bolts on underside of chassis rails 2 each side see fig 1.
 - b. 2 x M12 bolts located on the outside horizontal face of chassis rails 1 each side see fig 2.
 - c. 2 x M12 bolts located on the inside horizontal face of chassis rails 1 each side.
 - d. Lower the air condition box located on the drivers side via 3 x M 6 screws x 20 screws this will allow better access to the horizontal bolts (if fitted not all vehicle variants will have it fitted).
 - e. Don't remove the forward most bolt completely from chassis rails just enough to lower the tie down support frame see figure 2.
 - f. Retain the bolts for further fitment of tow bar.
 - g. Discard the tie down support frame.

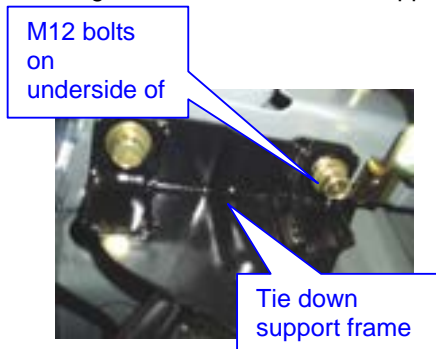

FIG 1



FIG 2

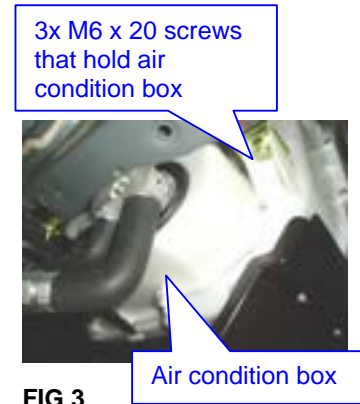
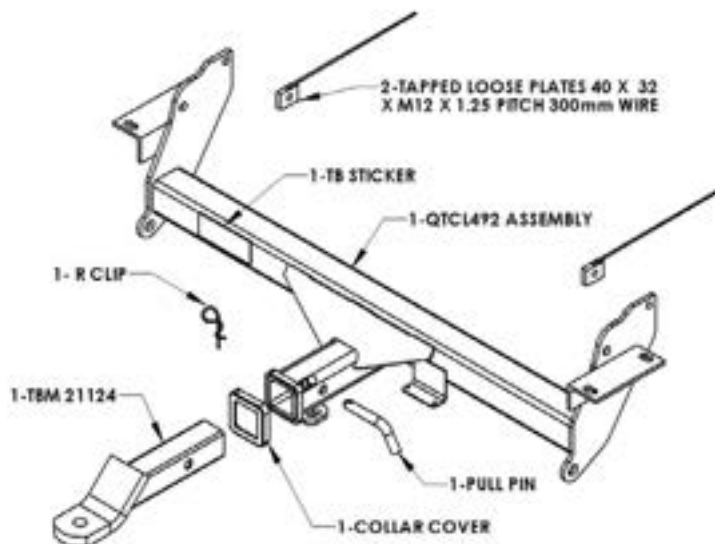

FIG 3

12. Fitment of tow bar to vehicle
 - a. Offer tow bar to vehicle so as to align with captive nuts on the underside of chassis rail.
 - b. Support tow bar with suitable jack stands.
 - c. Fit vertical bolts loosely first see fig1.
 - d. Fit 2 tapped plates on wire to forward most bolts loosely each side.
 - e. Fit rear horizontal bolts loosely.
 - f. Fasten vertical bolts to torque listing, then horizontal bolts to torque listing.
 - g. Refit air condition box if removed not all vehicle variants will have it fitted.





Wiring Loom Fitting Instructions
To Suit Mitsubishi Pajero Wagon LWB & SWB
Part Number 100013-WL

Wiring Loom Installation Instructions

Mitsubishi Pajero Wagon LWB & SWB
Part No: 100013-WL

Tail Harness Length Require: 1200mm
ECU Required: 04826
RPA Override Switch Part No: 04848 (If Fitted)

Wiring Loom Installation Time: Approx 40 Mins



Wiring Loom Fitting Instructions
To Suit Mitsubishi Pajero Wagon LWB & SWB
Part Number 100013-WL

1. Remove the LHS and RHS luggage compartment side floor trims and LHS and RHS pivot covers.
2. Remove the rear folding seat.
3. Remove the rear trim by removing 3 panel clips.
4. Fold forward the centre passenger seats and lock into position. Remove the underside floor carpet and fasteners.
5. Release the seat belt bolts on the RHS luggage compartment areas. Remove the RHS luggage compartment upper trim.
6. Remove the LHS rear passenger sill trim.
7. Remove the luggage compartment RHS trim by removing its fasteners. Pry the trim back and disconnect the 12V aux power connector
8. Remove the front passenger sill trim.
9. Remove the front passenger kick panel fasteners and kick panel.
10. Remove the glove compartment upper trim and the glove compartment.
11. In the engine bay, connect the Power Harness (P/No: 100013-PH) ring terminal to the battery positive terminal onto the battery.
12. In the LHS of the engine bay, locate and remove the grommet from the firewall.
13. Punch a hole in the grommet and feed the Power Harness (P/No: 100013-PH) connector through the grommet.
14. Feed the harness into the firewall ensuring the harness grommet makes a good seal.
15. Locate the 3-way male connector which is taped back to the main harness in the LHS kick trim area.
16. Retrieve the Power Harness from the cabin firewall and connect the Power Harness connector to the kick panel connector.
17. At the RHS luggage compartment area, disconnect the 9-way female break out connector and connect the trailer patch harness (P/No: 100013-P) into it.
18. Secure the Power Harness ring terminal onto the grounding point located at the rear of the luggage compartment area.
19. Secure the Trailer Patch ring terminal using an M6 screw onto the vehicle grounding point.



Wiring Loom Fitting Instructions
To Suit Mitsubishi Pajero Wagon LWB & SWB
Part Number 100013-WL

20. From underneath the RHS of the vehicle, locate and remove the grommet.
21. Secure the Tail Harness socket onto the towbar mounting bracket using M4 fasteners.
22. Secure guide wire onto the tail harness (tail length 1200mm) connector and then feed the tail harness into the vehicle luggage compartment area. Adjust the grommet into position ensuring the grommet is seated correctly.
23. From inside of the vehicle, retrieve the Tail Harness (1200mm length) and connect it to the Trailer Patch Harness tail connector.
24. Test the Trailer socket using a light board or multi-meter.
25. Secure the all harnesses using cables ties.
26. Refit all removed parts and secure all fasteners.
27. Place instructions in glove box after fitment.