



Tow bar Fitting Instructions  
To Suit MITSUBISHI GRANDIS BA 5-04-ON  
Does not suit VRX models.  
Part Number QTCL641  
Rating 1800Kg

- 1 Ensure all hardware items have been included
- 2 **Removing the rear tail lights.**
- 3 Remove tail lights via removal of the following items
  - a) 8-screws under boot lid
  - b) 2-10mm nuts behind plastic panel inside.
- 4 **Removing the bumper bar.**
- 5 Remove bumper bar via removal of the following items.
  - a) 2-10mm nuts in tail light cavity
  - b) 2-10mm screws in boot lid cavity.
  - c) 3-plastic trim buttons under side of bumper
  - d) 4-10mm screws inner wheel arch
  - e) 3-plastic trim buttons inner wheel arch
  - f) 2-10mm screws inner wheel arch.
  - g) 2-plastic inserts on rear guards
- 6 Remove rear tow hook via four M12 bolts then discard bolts & tow hook.
- 7 Drop exhaust via 3 flange bolts then remove from 3 rubber hangers.
- 8 Mark rear panel 115 mm wide x 15mm deep on each side in line with chassis rails to allow the side arms to reach up vertical face of chassis.
- 9 Lift tow bar into position so that holes in side plate align with captive holes on outside of each chassis rail.
- 10 Fit 2 M12 x 40 x 1.25 pitch bolts to each side of chassis rail loosely.
- 11 Fit loose plate between tow bar & underside of chassis rail each side.
- 12 Fit 4 remaining M12 x 40 x 1.25 pitch bolts to captive nuts on underside of chassis rails.
- 13 Using holes in centre mount as guide drill through 10.5mm see.
- 14 Feed through M10 bolts on wire through access hole on rear panel located each side of centre mount.
- 15 Fasten M10 spring washers & nuts then trim any excess wire.
- 16 Fold back second bumper tag from driver's side to slide tail assembly across once tail assembly is in position fold bumper tag back.
- 17 Attach tail assembly to main assembly via the M12 x 100 bolts & M12 whiz nut supplied.
- 18 Using holes of bracket on rear of tail assembly as a guide drill through 10.5mm then feed through M10 bolts on wire as shown in diagram below fit nuts & spring washers see.
- 19 Fasten all bolts to torque listing below.
- 20 Cut bumper bar as per diagram see **bumper cut drawing**.
- 21 Refit bumper & tail lights in reverse steps 5 g to 3 a.

**RECOMMENDED ASSEMBLY TORQUE LISTING**

<u>Diameter</u>	<u>Grade 8.8 Bolt</u>
	Nm
M6	9.5
M8	21.7
M10	43.4
M12	77.3
M14	121.0
M16	189.8

# TRAILBOSS

Tow bar Fitting Instructions  
 To Suit MITSUBISHI GRANDIS BA 5-04-ON  
 Does not suit VRX models.  
 Part Number QTCL641  
 Rating 1800Kg

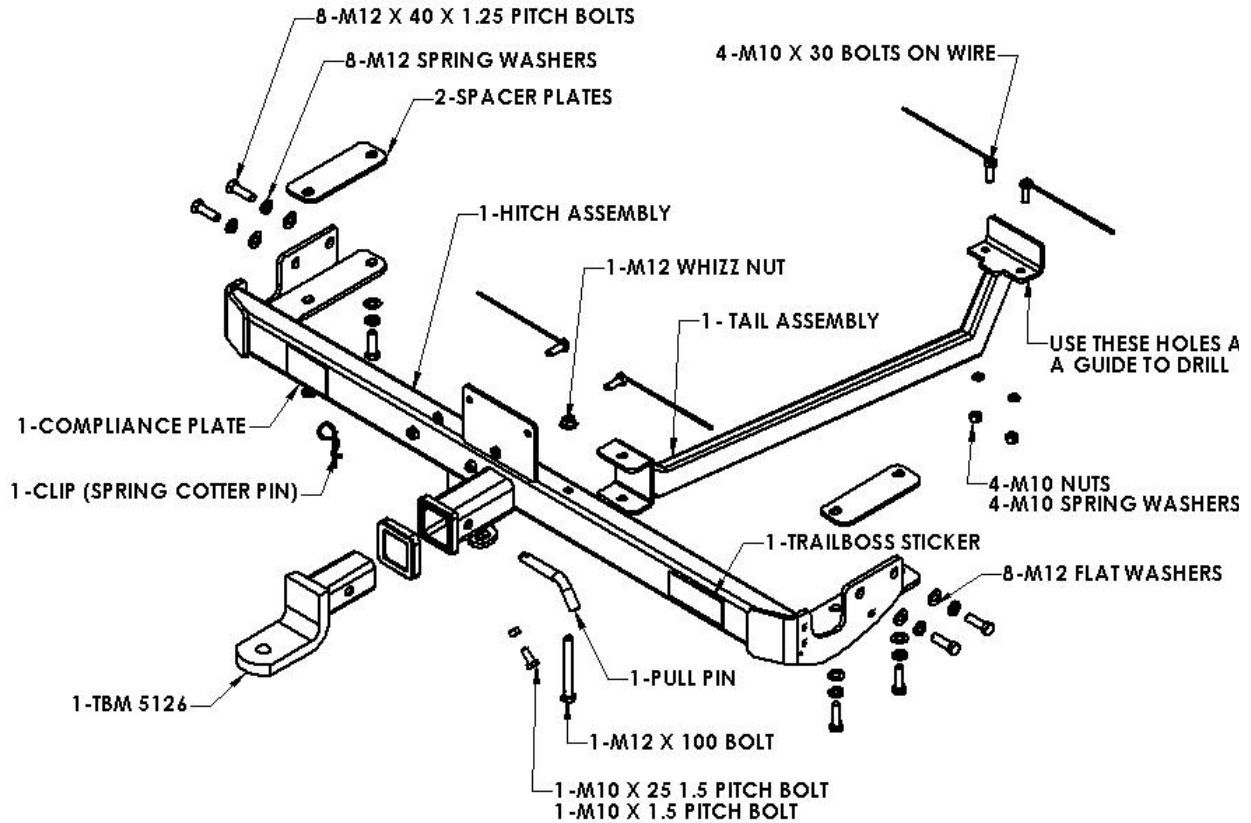

BUMPER CUT  
 DRAWING

