

TRAILBOSS

Towbar Fitting Instructions
To Suit **MITSUBISHI TRITON MQ MY19 CL4 UTE**
Part Number **QTCL657L**
Rating **3100/310 kg**

PLACE THESE INSTRUCTIONS IN THE VEHICLE'S GLOVEBOX AFTER INSTALLATION IS COMPLETED

WARNING:

1. Do not, drill, cut, weld or otherwise modify the tow bar.
2. If you are using electric welding on a motor vehicle, **always** check that the vehicle is not equipped with electronic engine or instrument management equipment. Failure to do so could **destroy** any onboard computers. If in doubt, check with the vehicle's manufacturer.
3. The high tensile fasteners supplied with this product were used to achieve the specified rating. If replacement is required ensure that fasteners of the same rating & quality are used. Contact an authorised **Trailboss** dealer if further information is required.
4. If TBM is used in inverted position tow ball may make contact with rear tailgate when lowered, which could cause damage.

General:

1. Ensure all hardware items have been included refer to assembly diagram.
2. It is recommended that the instructions are read through and completely understood before making any attempt to fit this product.
3. Be wary of any changes to vehicle designs or other accessories that may conflict with the installation of this product.
4. Before drilling ensure that the area is clear of fuel, electrical & other components.
5. All holes drilled into the body panels shall have all burrs & swarf removed then coated with a suitable rust preventative paint.
6. For vehicles that require the bumper to be cut. Ensure cut out area is in correct position on the vehicle prior to cutting the bumper.
7. The high tensile fasteners supplied with this product were used to achieve the specified rating. If replacement is required ensure that fasteners of the same rating & quality are used. Contact an authorized **Trailboss** dealer if further information is required.
8. Ensure that all hardware is fastened to torque list below check fasteners on regular basis.
9. Tow bar load rating sticker provided with this product shall be conspicuously located on inside rear end of the driver's door. **(See diagram below).**
10. Trailboss recommends that you check your tow ball to ensure that it complies with the Australian standards **AS 4177.2**.
11. **PLEASE NOTE:** It is advised to remove your LUG or TBM when not actually towing so as to produce a clear view of the vehicles registration plate if obscured, and to also provide maximum available departure angle

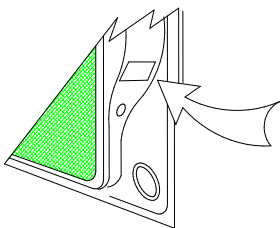

Place load rating sticker
inside driver's door here

FOR TRAILER TOWING PURPOSES ONLY
For towing capacity details please refer to vehicle owner's manual or to the manufacturer. Overloading can void your warranty.

RECOMMENDED ASSEMBLY TORQUE LISTING

Diameter	Grade 8.8 Bolt
M6	9.5 Nm
M8	21.7 Nm
M10	43.4 Nm
M12	77.3Nm
M14	146 Nm

Tow bar Maintenance and Care.

Trailboss recommends that bolt torque's, as listed below, are routinely and regularly inspected and checked for correct tension. Replace any worn or defective parts.

We recommended to remove Tow Ball Mounts (TBM's, tongues or lugs) when not being used for any considerable length of time.

So as to avoid injury, when not towing it is suggested that the tongue, Pull Pin and R-clip are removed then stored in a safe, clean and dry place, away from excessive moisture.

Hitch Pull Pins and spring "R" clips are regularly checked for proper installation. Replace any worn or defective parts.

Cequent Customer Service
Ph: 1800 812 017 Fax: 03 9898 3299
Email: info@cequent.com.au
Post: PO Box 4050, Dandenong South VIC 3175

TRAILBOSS

Towbar Fitting Instructions
 To Suit **MITSUBISHI TRITON MQ MY19 CL4 UTE**
 Part Number **QTCL657L**
 Rating **3100/310 kg**

PLACE THESE INSTRUCTIONS IN THE VEHICLE'S GLOVEBOX AFTER INSTALLATION IS COMPLETED

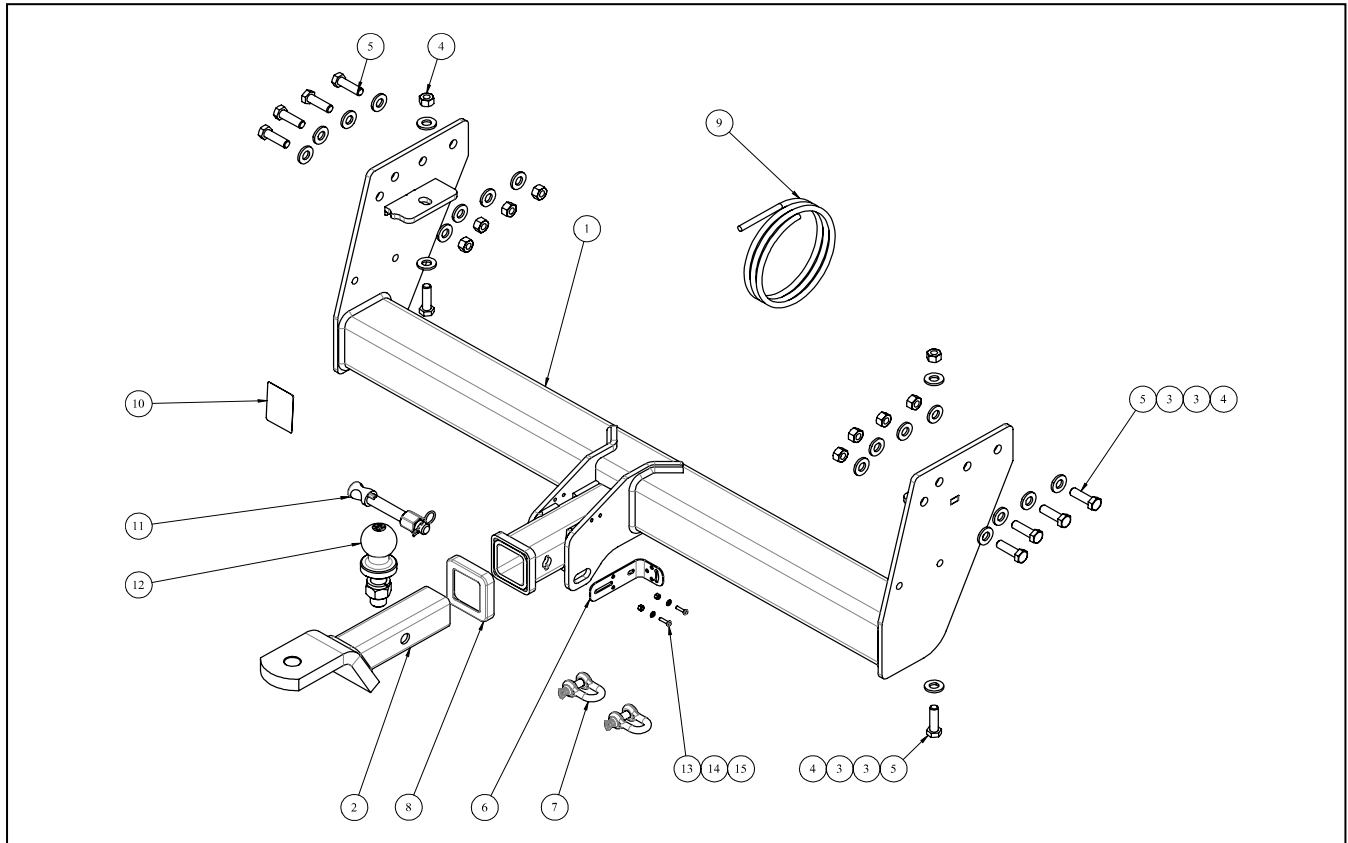

ITEM	DESCRIPTION	QTY	ITEM	DESCRIPTION	QTY
1	TRITON WITH STEP WELDED ASSY	1	9	WIRING LOOM	1
2	CLASS 4 TBM	1	10	ACRYLIC COMPLIANCE LABEL	1
3	WASHER PLAIN 1/2X1-1/8X16G	20	11	SILENT HITCH PIN – SILVER	1
4	M12x1.75 HEX NUT PC8	10	12	TOWBALL 50mm	1
5	SET SCREW M12-1.75x40 GR10.9	10	13	M4 WASHER	2
6	UNIVERSAL PLUG BRACKET KIT	1	14	SCREW PAN HD M4 X 16 X 0.7P G4.6	2
7	"D" SHACKLE 10mm	2	15	NUT NYLON LOCK HEX HD M4X0.7P G8	2
8	HITCH BOX COLLAR COVER	1			

Cequent Customer Service
 Ph: 1800 812 017 Fax: 03 9898 3299
 Email: info@cequent.com.au
 Post: PO Box 4050, Dandenong South VIC 3175

TRAILBOSS

Towbar Fitting Instructions
To Suit **MITSUBISHI TRITON MQ MY19 CL4 UTE**
Part Number **QTCL657L**
Rating **3100/310 kg**

PLACE THESE INSTRUCTIONS IN THE VEHICLE'S GLOVEBOX AFTER INSTALLATION IS COMPLETED

1. Remove step from vehicle secured with 2 bolts per side, making sure to disconnect reversing sensors if fitted.



2. Remove LH Step bracket from vehicle secured with 2 x bolts complete with 2 x washers and 1 x nut per bolt and discard.

Repeat for other side.



3. Lift towbar to vehicle and secure with 5 x Bolts complete with 2 x washers and 1 x nut per bolt on both the LH & RH side.

Torque all fasteners to 125Nm.

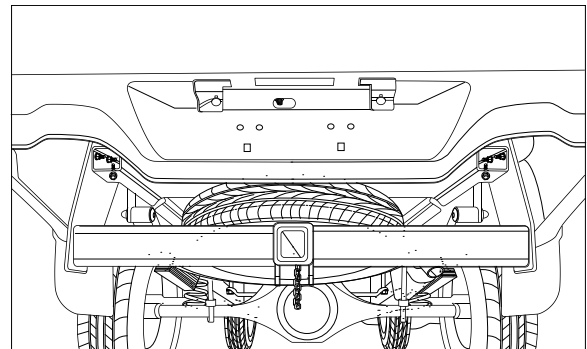

Cequent Customer Service

Ph: 1800 812 017 Fax: 03 9898 3299

Email: info@cequent.com.au

Post: PO Box 4050, Dandenong South VIC 3175

TRAILBOSS

Towbar Fitting Instructions
To Suit **mitsubishi triton mq my19 cl4 ute**
Part Number **QTCL657L**
Rating **3100/310 kg**

PLACE THESE INSTRUCTIONS IN THE VEHICLE'S GLOVEBOX AFTER INSTALLATION IS COMPLETED

4. Refit the step to vehicle, using the existing fasteners, to the towbar sidearms.

Torque the fasteners to 50Nm.

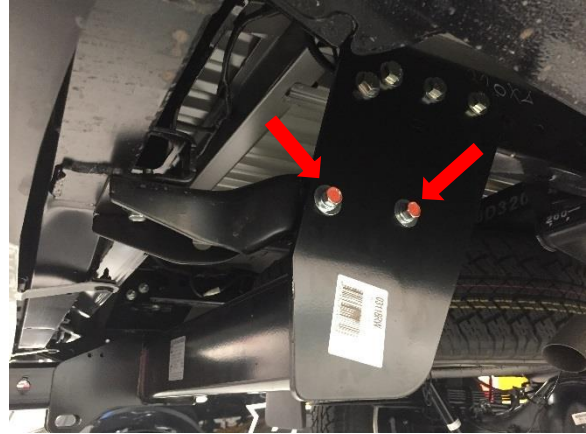

Cequent Customer Service
Ph: 1800 812 017 Fax: 03 9898 3299
Email: info@cequent.com.au
Post: PO Box 4050, Dandenong South VIC 3175



Wiring Loom Fitting Instructions
To Suit Mitsubishi Triton
Part Number 102148-WL

Wiring Loom Installation Instructions

Mitsubishi Triton

Part No: 102148-WL

ECU: N/A

Tail Harness Length Required: 1200mm

RPA Disable Information: N/A

Electric Brake Input Location: Blue Wire near Connector
Breakout

Wiring Loom Installation Time: Approx 15 Mins



Wiring Loom Fitting Instructions
To Suit Mitsubishi Triton
Part Number 102148-WL

1. In the engine bay, disconnect the negative vehicle battery cable.
2. Under the vehicle LHS near the spare wheel, locate the vehicle black 10-way connector pair.
3. Disconnect the vehicle connectors and patch in the supplied Patch Harness in between the vehicle connectors.
4. Tie up excess length and waterproof relays to the existing vehicle harness.
5. Route the power and ground wire under the vehicle towards the front of the vehicle following the left hand chassis rail.
6. Route the power and ground wire up in the engine bay, towards the vehicle battery.
Note: Keep harness routing clear of all sharp edges, moving parts and places of extreme heat.
7. Connect the orange power wire ring terminal to the battery.
8. Connect the white ground wire to the vehicle earthing point.
9. Secure tail harness to towbar
10. Connect the tail harness (tail length 1200mm) 8-way connector to the trailer patch mating 8-way connector.
11. Apply silicone grease (not supplied) to waterproof connector.
12. Secure all harnesses using supplied Cable Ties.
13. Test the trailer patch function using a light board or multi-meter.
14. Place the fitting instructions in the glove box after fitment.



FITTING INSTRUCTIONS

Silent Anti-Rattle Hitch Pin (PR0001)

• These fitting instructions are supplied to ensure understanding of how the HITCH PIN should be fitted and used correctly.

• Once installed, we recommend **ALL** instructions are kept and placed in the vehicle glove box.

NOTE: Routine maintenance and inspection of the towbar & HITCH PIN is required. Regularly inspect for wear and check the tightness of the Hitch Pin. Follow instructions below to retighten the nut when necessary.

***Do not tow with your vehicle if the R CLIP or the HITCH PIN is loose or missing. Replacement parts are available from your Pro Series Distributor.**

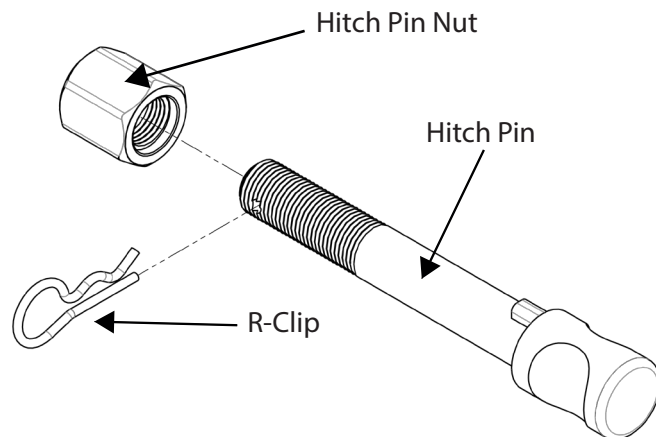

Fig 1. Silent Anti-Rattle Hitch Pin assembly

STEP 1

Insert Trailer Ball Mount (TBM) into towbar HITCHBOX, aligning hole in TBM SHANK with hole in HITCHBOX (Fig 2).

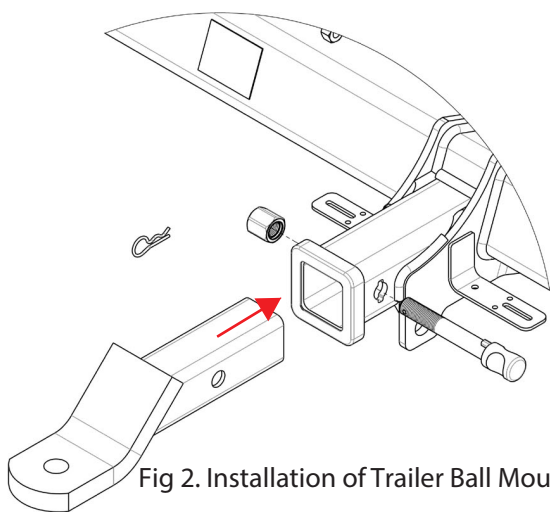

Fig 2. Installation of Trailer Ball Mount

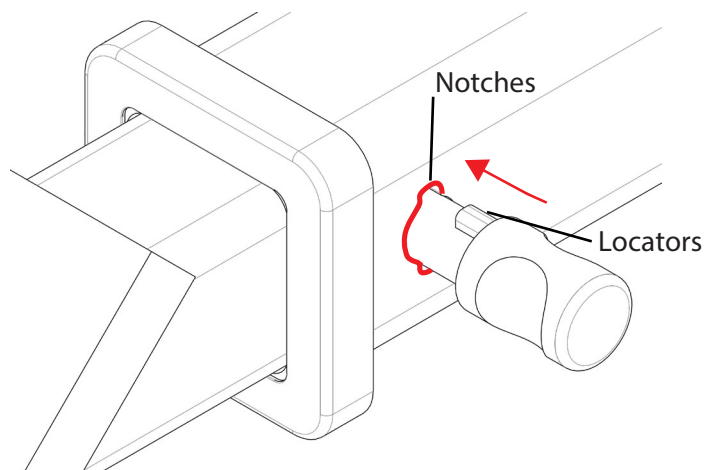

Fig 3. Silent Anti-Rattle Hitch Pin orientation

STEP 2

Insert HITCH PIN through hole in HITCHBOX and hole in TBM SHANK; ensure the LOCATORS are inserted into the NOTCHES in the HITCHBOX (Fig. 3).

STEP 3

Screw HITCH PIN NUT onto HITCH PIN ; tighten HITCH PIN NUT until finger tight, ensuring TBM is restrained from movement.

STEP 4

Tighten HITCH PIN NUT by turning nut a further 1/8th of a turn in the clockwise direction using a 24mm spanner (Fig. 4).

STEP 5

Install HITCH PIN R CLIP through the hole on the HITCH PIN (Fig. 1).

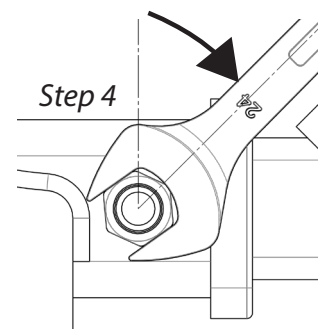

Fig 4. Tightening of Silent Anti-Rattle Hitch Pin Nut