



Towbar Fitting Instructions
 To Suit **NISSAN PATROL Y61 CAB CHASSIS –LEAF SPRING**
 Part Number **QTDS855L**
 Rating **3200/320 kg**

PLACE THESE INSTRUCTIONS IN THE VEHICLE'S GLOVEBOX AFTER INSTALLATION IS COMPLETED

WARNING:

1. Do not, drill, cut, weld or otherwise modify the tow bar.
2. If you are using electric welding on a motor vehicle, **always** check that the vehicle is not equipped with electronic engine or instrument management equipment. Failure to do so could **destroy** any onboard computers. If in doubt, check with the vehicle's manufacturer.
3. The high tensile fasteners supplied with this product were used to achieve the specified rating. If replacement is required ensure that fasteners of the same rating & quality are used. Contact an authorised **Trailboss** dealer if further information is required.
4. If TBM is used in inverted position tow ball may make contact with rear tailgate when lowered, which could cause damage.

General:

1. Ensure all hardware items have been included refer to assembly diagram.
2. It is recommended that the instructions are read through and completely understood before making any attempt to fit this product.
3. Be wary of any changes to vehicle designs or other accessories that may conflict with the installation of this product.
4. Before drilling ensure that the area is clear of fuel, electrical & other components.
5. All holes drilled into the body panels shall have all burrs & swarf removed then coated with a suitable rust preventative paint.
6. For vehicles that require the bumper to be cut. Ensure cut out area is in correct position on the vehicle prior to cutting the bumper.
7. The high tensile fasteners supplied with this product were used to achieve the specified rating. If replacement is required ensure that fasteners of the same rating & quality are used. Contact an authorized **Trailboss** dealer if further information is required.
8. Ensure that all hardware is fastened to torque list below check fasteners on regular basis.
9. Tow bar load rating sticker provided with this product shall be conspicuously located on inside rear end of the driver's door. **(See diagram below).**
10. Trailboss recommends that you check your tow ball to ensure that it complies with the Australian standards **AS 4177.2**.
11. **PLEASE NOTE:** It is advised to remove your lug or tbm when not actually towing so as to produce a clear view of the vehicles registration plate if obscured, and to also provide maximum available departure angle
12. Pull Pin must be fit in down position.

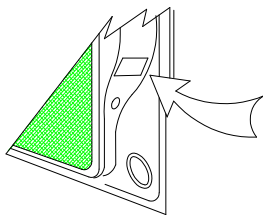

Place load rating sticker
inside driver's door here

FOR TRAILER TOWING PURPOSES ONLY
 For towing capacity details please refer to vehicle owner's manual or to the manufacturer. Overloading can void your warranties.

RECOMMENDED ASSEMBLY TORQUE LISTING

Diameter	Grade 8.8 Bolt
M6	9.5 Nm
M8	21.7 Nm
M10	43.4 Nm
M12	77.3Nm
M14	146 Nm
M16	189.8 Nm

Tow bar Maintenance and Care.

Trailboss recommends that bolt torque's, as listed below, are routinely and regularly inspected and checked for correct tension. Replace any worn or defective parts.
 We recommended to remove Tow Ball Mounts (TBM's, tongues or lugs) when not being used for any considerable length of time.
 So as to avoid injury, when not towing it is suggested that the tongue, Pull Pin and R-clip are removed then stored in a safe, clean and dry place, away from excessive moisture.
 Hitch Pull Pins and spring "R" clips are regularly checked for proper installation. Replace any worn or defective parts.

TRAILBOSS

Towbar Fitting Instructions
 To Suit **NISSAN PATROL Y61 CAB CHASSIS -LEAF SPRING**
 Part Number **QTDS855L**
 Rating **3200/320 kg**

PLACE THESE INSTRUCTIONS IN THE VEHICLE'S GLOVEBOX AFTER INSTALLATION IS COMPLETED

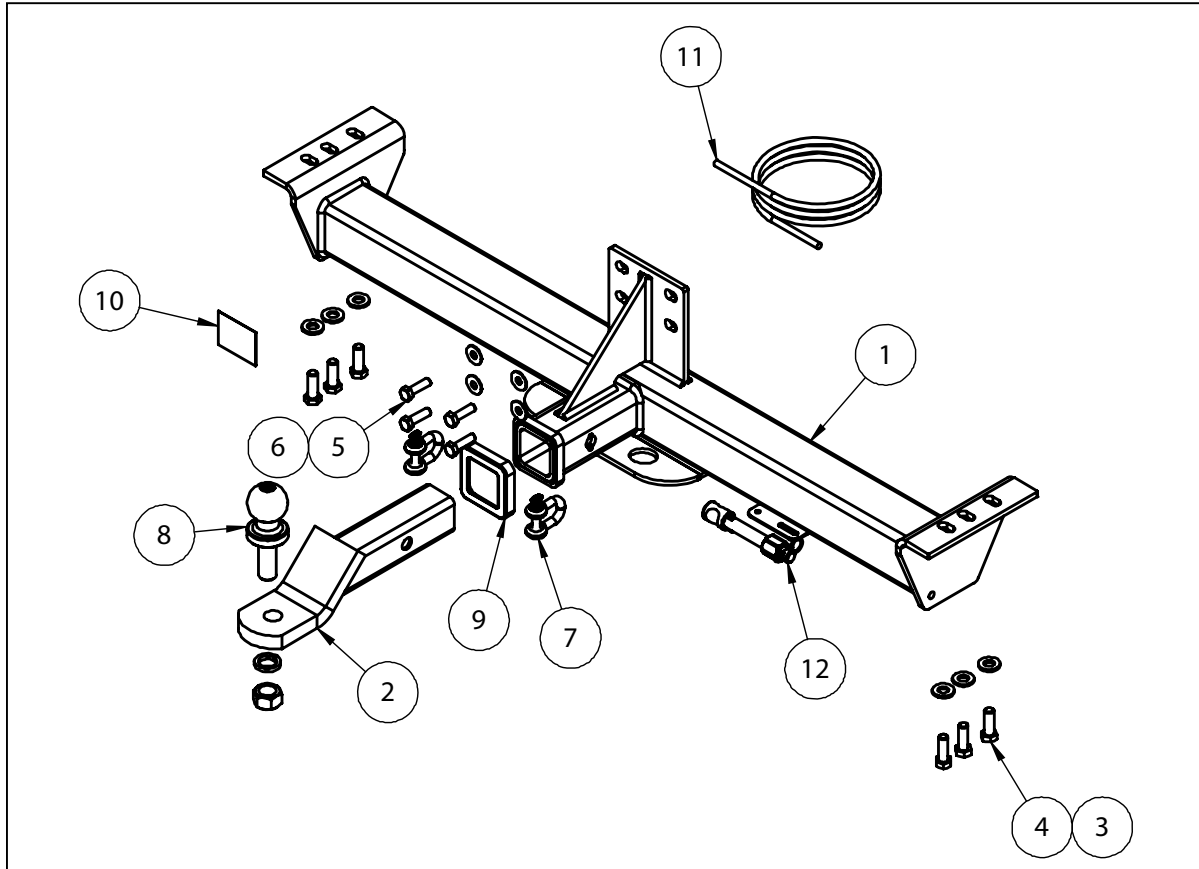

QTY.	DESCRIPTION	ITEM NO.
1	WELDED ASSY	1
1	TBM ASSY	2
6	WASHER FLAT ½" x 1 1/8" x 1/8"	3
6	SET SCREW M12-1.25x35	4
4	SET SCREW HEX HD M10x35x1.25P	5
4	WASHER FT 3/8 x1x16 BRT Z/P	6
2	10mm "D" SHACKLE	7
1	50mm TOWBALL	8
1	HITCH BOX COLLAR COVER	9
1	ACRYLIC CP	10
1	WIRING LOOM	11
1	ANTI RATTLE PULL PIN ASSY	12



Towbar Fitting Instructions
To Suit **NISSAN PATROL Y61 CAB CHASSIS –LEAF SPRING**
Part Number **QTDS855L**
Rating **3200/320 kg**

PLACE THESE INSTRUCTIONS IN THE VEHICLE'S GLOVEBOX AFTER INSTALLATION IS COMPLETED

INSTRUCTION:

1. Offer Towbar to rear chassis of vehicle.
2. Loosely secure bar to central mounting point using 4x M10 Set Screws, complete with 1x Flat Washer per Set Screw.
3. Loosely secure Towbar to captive Nuts in chassis rails using 3x M12 Bolts per chassis rail, complete with 1x Flat Washer per Bolt.
4. Tighten all fasteners to torque specified on page 1 of this document.



Wiring Loom Fitting Instructions
To Suit Nissan GU Patrol
Part Number 100108-WL

Wiring Loom Installation Instructions

Nissan GU Patrol
Part No: 100108-WL

Tail Harness Length Required: 1200mm
RPA Override Switch Part No: 04848 (If Fitted)

Wiring Loom Installation Time: Approx 30 Mins



Wiring Loom Fitting Instructions
To Suit Nissan GU Patrol
Part Number 100108-WL

Note: Steps 1 & 2 are only required to find the vehicle reverse signal wire.

1. Dislodge the LHS tail light by first removing the two Phillips head screws.
2. Disconnect the LHS tail light connector and remove the LHS tail light.
3. From underneath the vehicle, locate and disconnect the LHS bumper light 4-way connectors.
4. Patch the Trailer Harness mating 4-way connectors in between the vehicle LHS bumper light connectors.

Note: Steps 5-7 are only required to find the vehicle reverse signal wire.

5. In the LHS rear wheel arch, locate and pierce a hole in the grommet.
6. Route the Trailer Harness "BLACK" reverse wire terminal through the grommet and into the LHS tail light cavity.
7. Following the table below, connect the ezy tap to the vehicle reverse signal wire and then connect the trailer harness terminal to the ezy tap .

Function	Trailer Patch	Vehicle Connector
REVERSE	BLACK	YELLOW

8. Route the Trailer Harness along the rear of the vehicle and towards the RHS tail light connectors.
9. From underneath the vehicle, locate and disconnect the RHS bumper 4-way connectors.
10. Patch the Trailer Harness mating 4-way connectors in between the vehicle RHS tail light connectors.
11. Using a self tapping tech screw, secure the Trailer Harness ground ring terminal to the vehicle chassis.
12. Mount the Trailer Socket to the towbar mounting bracket using M4 fasteners (not supplied).
13. Route the Tail Harness (Tail Length: 1200mm) along the towbar and towards the Trailer Harness 8-way connector.
14. Connect the tail harness 8-way connector to the Trailer Harness mating 8-way connector.
15. Waterproof the back of the 8-way connectors using electrical grease or silicone.



Wiring Loom Fitting Instructions
To Suit Nissan GU Patrol
Part Number 100108-WL

16. Test the Trailer Harness function using a light board or multi-meter.
17. Secure all harnesses using cables ties (not supplied).
18. Re-fit all removed parts and secure all fasteners, ensuring there are no squeaks or rattles.
19. Place the instructions in the glove box after fitment.



FITTING INSTRUCTIONS

Silent Anti-Rattle Hitch Pin (PR0001)

• These fitting instructions are supplied to ensure understanding of how the HITCH PIN should be fitted and used correctly.

• Once installed, we recommend **ALL** instructions are kept and placed in the vehicle glove box.

NOTE: Routine maintenance and inspection of the towbar & HITCH PIN is required. Regularly inspect for wear and check the tightness of the Hitch Pin. Follow instructions below to retighten the nut when necessary.

***Do not tow with your vehicle if the R CLIP or the HITCH PIN is loose or missing. Replacement parts are available from your Pro Series Distributor.**

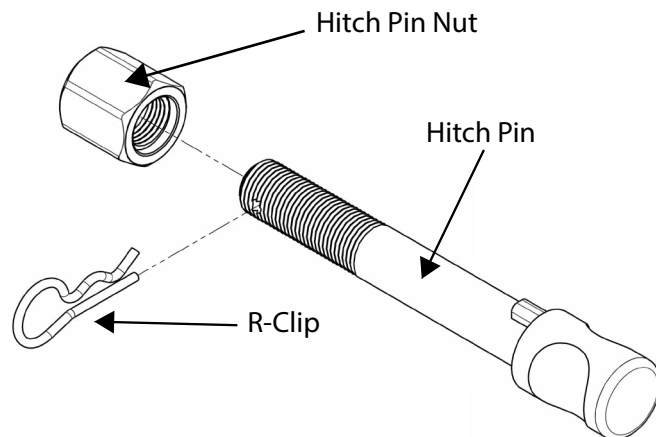

Fig 1. Silent Anti-Rattle Hitch Pin assembly

STEP 1

Insert Trailer Ball Mount (TBM) into towbar HITCHBOX, aligning hole in TBM SHANK with hole in HITCHBOX (Fig 2).

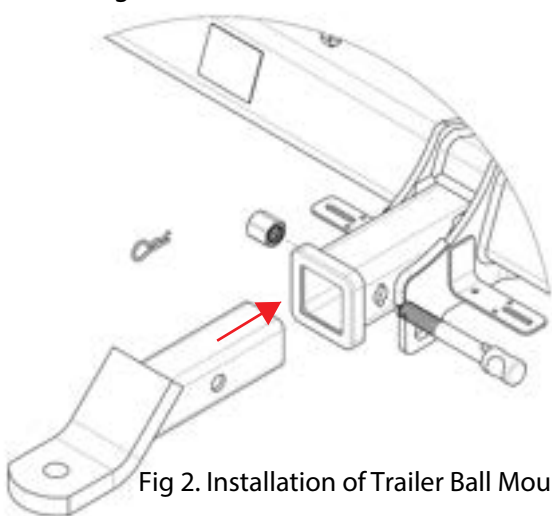

Fig 2. Installation of Trailer Ball Mount

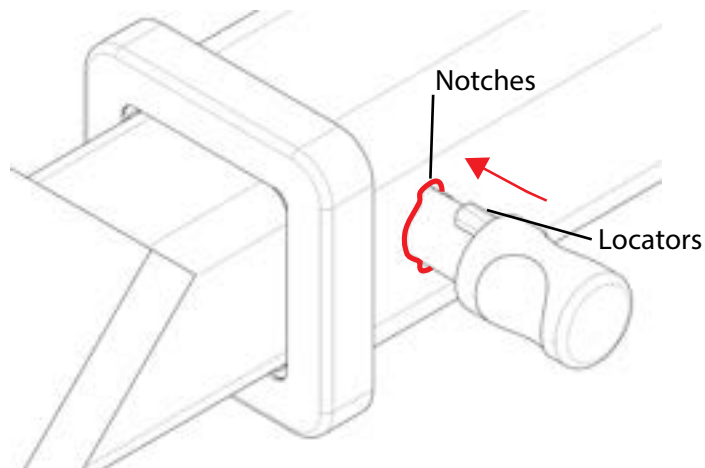

Fig 3. Silent Anti-Rattle Hitch Pin orientation

STEP 2

Insert HITCH PIN through hole in HITCHBOX and hole in TBM SHANK; ensure the LOCATORS are inserted into the NOTCHES in the HITCHBOX (Fig. 3).

STEP 3

Screw HITCH PIN NUT onto HITCH PIN ; tighten HITCH PIN NUT until finger tight, ensuring TBM is restrained from movement.

STEP 4

Tighten HITCH PIN NUT by turning nut a further 1/8th of a turn in the clockwise direction using a 24mm spanner (Fig. 4).

STEP 5

Install HITCH PIN R CLIP through the hole on the HITCH PIN (Fig. 1).

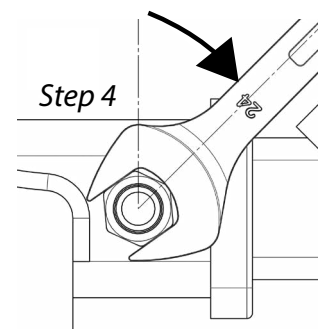

Fig 4. Tightening of Silent Anti-Rattle Hitch Pin Nut