

TRAILBOSS

Towbar Fitting Instructions To Suit **NISSAN X-TRAIL T32 CL4** Part Number **QTDS859L** Rating **2000/200 kg**

PLACE THESE INSTRUCTIONS IN THE VEHICLE'S GLOVEBOX AFTER INSTALLATION IS COMPLETED

WARNING:

1. Do not, drill, cut, weld or otherwise modify the tow bar.
2. If you are using electric welding on a motor vehicle, **always** check that the vehicle is not equipped with electronic engine or instrument management equipment. Failure to do so could **destroy** any onboard computers. If in doubt, check with the vehicle's manufacturer.
3. The high tensile fasteners supplied with this product were used to achieve the specified rating. If replacement is required ensure that fasteners of the same rating & quality are used. Contact an authorised **Trailboss** dealer if further information is required.
4. If TBM is used in inverted position tow ball may make contact with rear tailgate when lowered, which could cause damage.

General:

1. Ensure all hardware items have been included refer to assembly diagram.
2. It is recommended that the instructions are read through and completely understood before making any attempt to fit this product.
3. Be wary of any changes to vehicle designs or other accessories that may conflict with the installation of this product.
4. Before drilling ensure that the area is clear of fuel, electrical & other components.
5. All holes drilled into the body panels shall have all burrs & swarf removed then coated with a suitable rust preventative paint.
6. For vehicles that require the bumper to be cut. Ensure cut out area is in correct position on the vehicle prior to cutting the bumper.
7. The high tensile fasteners supplied with this product were used to achieve the specified rating. If replacement is required ensure that fasteners of the same rating & quality are used. Contact an authorized **Trailboss** dealer if further information is required.
8. Ensure that all hardware is fastened to torque list below check fasteners on regular basis.
9. Tow bar load rating sticker provided with this product shall be conspicuously located on inside rear end of the driver's door. **(See diagram below)**.
10. Trailboss recommends that you check your tow ball to ensure that it complies with the Australian standards **AS 4177.2**.
11. **PLEASE NOTE:** It is advised to remove your LUG or TBM when not actually towing so as to produce a clear view of the vehicles registration plate if obscured, and to also provide maximum available departure angle

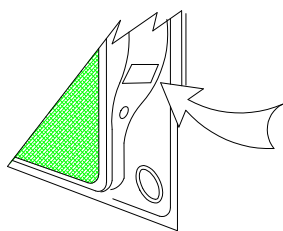

Place load rating sticker
inside driver's door here

FOR TRAILER TOWING PURPOSES ONLY
For towing capacity details please refer to vehicle owner's manual or to the manufacturer. Overloading can void your warranties.

RECOMMENDED ASSEMBLY TORQUE LISTING

<u>Diameter</u>	<u>Grade 8.8 Bolt</u>
M6	9.5 Nm
M8	21.7 Nm
M10	43.4 Nm
M12	77.3Nm
M14	146 Nm
M16	189.8 Nm

Tow bar Maintenance and Care.

Trailboss recommends that bolt torque's, as listed below, are routinely and regularly inspected and checked for correct tension. Replace any worn or defective parts.

We recommended to remove Tow Ball Mounts (TBM's, tongues or lugs) when not being used for any considerable length of time.

So as to avoid injury, when not towing it is suggested that the tongue, Pull Pin and R-clip are removed then stored in a safe, clean and dry place, away from excessive moisture.

Hitch Pull Pins and spring "R" clips are regularly checked for proper installation. Replace any worn or defective parts.

Cequent Customer Service
Ph: 1800 812 017 Fax: 03 9898 3299
Email: info@cequent.com.au
Post: PO Box 4050, Dandenong South VIC 3175

TRAILBOSS

Towbar Fitting Instructions
 To Suit **NISSAN X-TRAIL T32 CL4**
 Part Number **QTDS859L**
 Rating **2000/200 kg**

PLACE THESE INSTRUCTIONS IN THE VEHICLE'S GLOVEBOX AFTER INSTALLATION IS COMPLETED

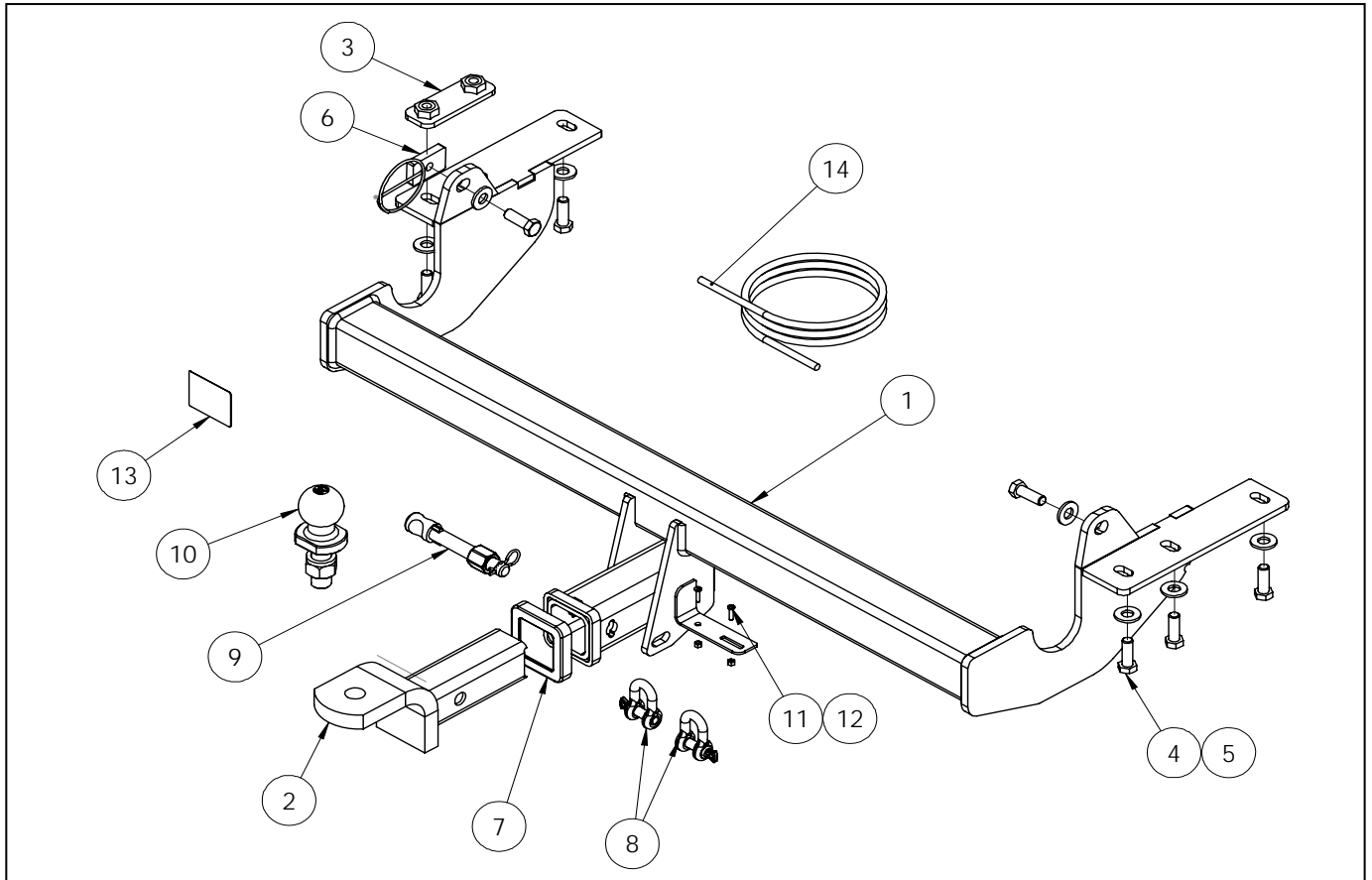

ITEM	DESCRIPTION	QTY
1	WELDED ASSY	1
2	TRAILER BALL MOUNT	1
3	CHASSIS BRACE PLATE	1
4	SET SCREW M12x35x1.25	8
5	WASHER FLAT M12x28.8x3	8
6	TAP PLATE WITH 300 WIRE M12x1.25	1
7	HITCH BOX COLLAR COVER	1

ITEM	DESCRIPTION	QTY
8	"D" SHACKLE 10MM	2
9	ANTI-RATTLE PULL PIN ASSY SILVER	1
10	TOWBALL 50MM	1
11	SCREW PAN HD M4x16x0.7P G4.6	2
12	NUT NYLON LOCK HEX HD M4x0.7P G8	2
13	ACRYLIC COMPLIANCE LABEL	1
14	WIRING LOOM	1

Cequent Customer Service
 Ph: 1800 812 017 Fax: 03 9898 3299
 Email: info@cequent.com.au
 Post: PO Box 4050, Dandenong South VIC 3175

TRAILBOSS

Towbar Fitting Instructions
To Suit **NISSAN X-TRAIL T32 CL4**
Part Number **QTDS859L**
Rating **2000/200 kg**

PLACE THESE INSTRUCTIONS IN THE VEHICLE'S GLOVEBOX AFTER INSTALLATION IS COMPLETED

1. Remove 3x Screws from inside of rear vehicle well.

Repeat for opposite side of vehicle.



2. Remove 1x Screw and 1x Scrivet located beneath wheel well, located rearwards of rear tire. [1]

Remove mudflap and store in safe place. [2]

Repeat for opposite side of vehicle.



3. Starting from lower rear end of wheel well, peel away wheel well Trim [1] to gain access to Screw located underneath. [2]

Remove Screw, repeat for opposite side of vehicle.

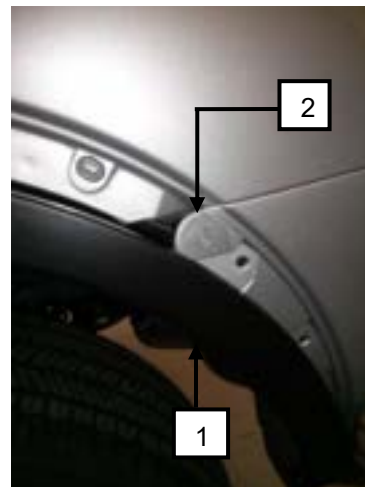

Cequent Customer Service
Ph: 1800 812 017 Fax: 03 9898 3299
Email: info@cequent.com.au
Post: PO Box 4050, Dandenong South VIC 3175

TRAILBOSS

Towbar Fitting Instructions
To Suit **NISSAN X-TRAIL T32 CL4**
Part Number **QTDS859L**
Rating **2000/200 kg**

PLACE THESE INSTRUCTIONS IN THE VEHICLE'S GLOVEBOX AFTER INSTALLATION IS COMPLETED

4. Remove 2x Scrivets securing lower Bumper trim to chassis.



5. Remove 2x Screws securing Bumper to rear Chassis Rail, located next to boot cavity.



6. Carefully peel away rear Bumper trim from main vehicle Chassis, and place to side in a safe place.

Remove rear Impact Beam by removing 6x M8 Screws securing beam to rear chassis.



Cequent Customer Service
Ph: 1800 812 017 Fax: 03 9898 3299
Email: info@cequent.com.au
Post: PO Box 4050, Dandenong South VIC 3175

TRAILBOSS

Towbar Fitting Instructions
To Suit **NISSAN X-TRAIL T32 CL4**
Part Number **QTDS859L**
Rating **2000/200 kg**

PLACE THESE INSTRUCTIONS IN THE VEHICLE'S GLOVEBOX AFTER INSTALLATION IS COMPLETED

7. Remove lower formed skirt from rear of vehicle Chassis by removing 4x Nuts.

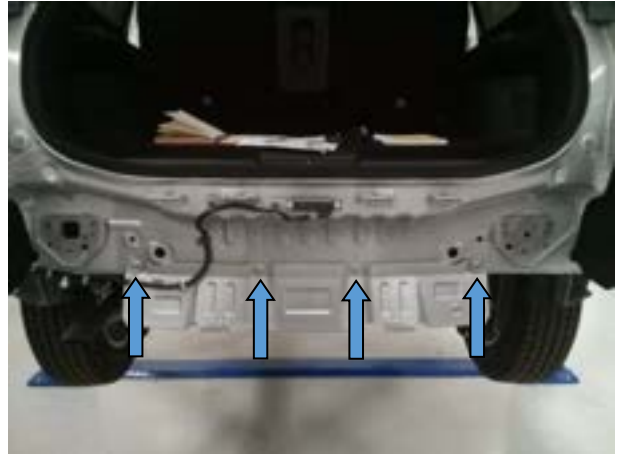

8. Remove factory Tow Hook from vehicle Chassis and discard.



9. Insert Nut plate into Passenger Chassis Rail, aligning Nuts with rearmost holes in Chassis Rail.

Offer Towbar to vehicle, lightly securing to vertical mounting points in Chassis rails.



Cequent Customer Service
Ph: 1800 812 017 Fax: 03 9898 3299
Email: info@cequent.com.au
Post: PO Box 4050, Dandenong South VIC 3175

TRAILBOSS

Towbar Fitting Instructions
To Suit **NISSAN X-TRAIL T32 CL4**
Part Number **QTDS859L**
Rating **2000/200 kg**

PLACE THESE INSTRUCTIONS IN THE VEHICLE'S GLOVEBOX AFTER INSTALLATION IS COMPLETED

10. Using supplied Nut plate on wire, secure Bolt to inside chassis rail wall.

Repeat for Driver's side with inbuilt captive Nut.

Secure all Bolts to recommended torques listed on Page 2.



11. Make a cut in vehicle Bumper. Starting from the centre, cut a slot is 110 mm wide and 140mm long.

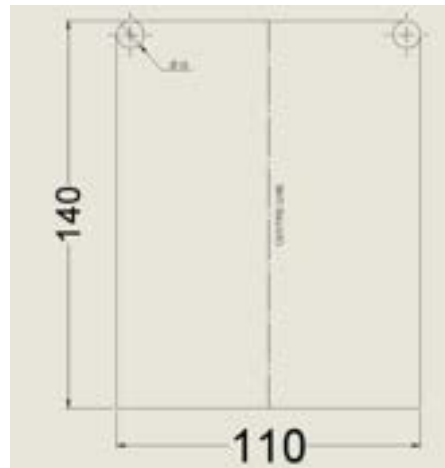

12. Reassemble Bumper assembly following steps 1-7 in reverse.

Cequent Customer Service
Ph: 1800 812 017 Fax: 03 9898 3299
Email: info@cequent.com.au
Post: PO Box 4050, Dandenong South VIC 3175



Wiring Loom Fitting Instructions
To Suit Nissan X-Trail MY14

Part Number 101176-WL

Wiring Loom Installation Instructions

Nissan X-Trail MY14

Part No: 101176-WL

ECU Required: 04826

Tail Harness Length Required: 1800mm

Wiring Loom Installation Time: Approx 45 Mins



Wiring Loom Fitting Instructions To Suit Nissan X-Trail MY14

Part Number 101176-WL

1. In the luggage compartment area, remove all the floor carpet and floor panel/trims from the vehicle. **If third row seats are installed, remove the third row seats first.**
2. Remove the two rear fasteners and door latch plastic trim and then remove the rear luggage compartment trim.
3. Remove the LHS luggage compartment trim cargo hooks. Remove the two screws from behind the fastener covers. Remove the LHS luggage compartment trim. On the LHS luggage compartment trim, remove the two cargo hooks by first removing the two bolts. **Repeat for the RHS.**
4. Remove the 30mm vehicle grommet. If the grommet is occupied, drill a 30mm hole nearby into the sheet metal area above. Spray on rust inhibitor after drilling (not supplied).
5. Inside the rear luggage compartment area, disconnect the RHS tail light connector. Patch the trailer patch harness (P/No: 101176-WL) RHS connectors in between the tail light connectors.
6. Route the trailer patch harness towards the LHS of the vehicle.
7. Disconnect the LHS tail light connectors. Patch the trailer patch harness LHS connectors in between the tail light connectors.
8. Connect the trailer patch harness ECU connector to the ECU. Secure the ECU to the rear quarter LHS sheet metal in a suitable location.
9. Secure the trailer patch ground ring terminal to the vehicle grounding point (LHS rear of the vehicle near LHS patch area). Connect the supplied power harness to the trailer patch 1-way connector and route the power harness out of the previously accessed rear quarter grommet hole.
10. Route the supplied power harness underneath the vehicle, along the LHS chassis and up to the engine bay battery area. **Note: Route the harness along a suitable location. Keep harness clear of any sharp or moving objects.**
11. Secure the power harness ring terminal to the battery positive terminal.
12. Mount the tail harness socket to the towbar mounting bracket using M4 fasteners (not supplied). Route the tail harness towards the LHS, up through the previously drilled grommet hole. Ensure the tail harness grommet is seated correctly and secured in place using a cable tie (not supplied).
13. Inside the luggage compartment, connect the tail harness (tail length 1800mm) 8-way connector to the trailer harness mating 8-way connector.
14. Test the Trailer Harness function using a Light Board or multi-meter.
15. Secure all Harnesses using cables ties (not supplied).
16. Re-fit all removed parts and secure all fasteners, ensuring there are no squeaks or rattles.
17. Place the instructions in the glove box after fitment.



FITTING INSTRUCTIONS

Silent Anti-Rattle Hitch Pin (PR0001)

• These fitting instructions are supplied to ensure understanding of how the HITCH PIN should be fitted and used correctly.

• Once installed, we recommend **ALL** instructions are kept and placed in the vehicle glove box.

NOTE: Routine maintenance and inspection of the towbar & HITCH PIN is required. Regularly inspect for wear and check the tightness of the Hitch Pin. Follow instructions below to retighten the nut when necessary.

***Do not tow with your vehicle if the R CLIP or the HITCH PIN is loose or missing. Replacement parts are available from your Pro Series Distributor.**

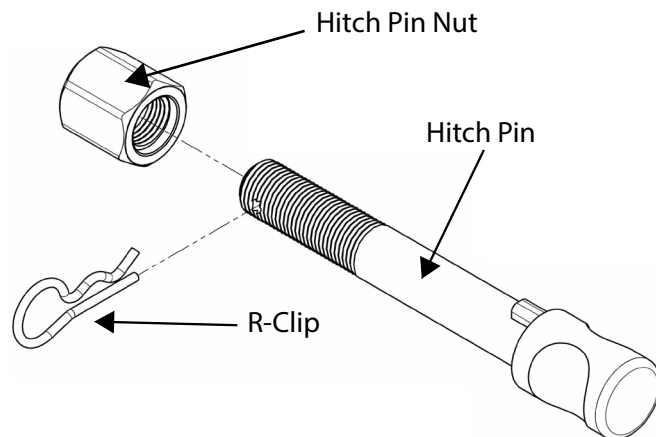

Fig 1. Silent Anti-Rattle Hitch Pin assembly

STEP 1

Insert Trailer Ball Mount (TBM) into towbar HITCHBOX, aligning hole in TBM SHANK with hole in HITCHBOX (Fig 2).

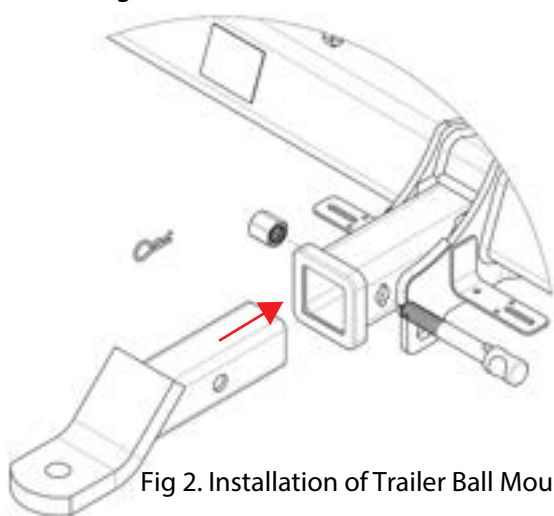

Fig 2. Installation of Trailer Ball Mount

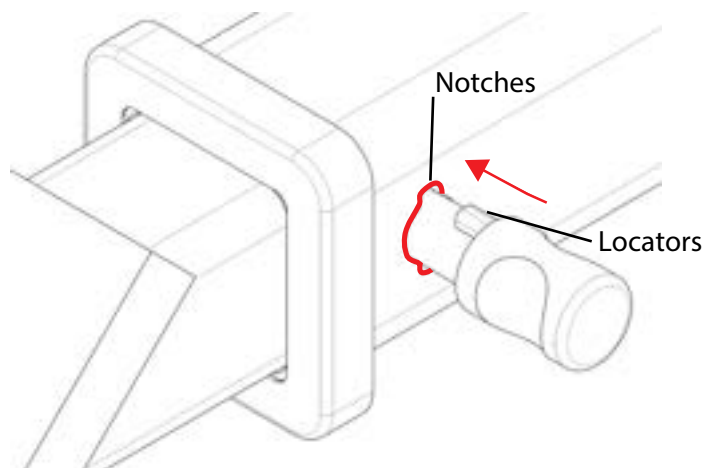

Fig 3. Silent Anti-Rattle Hitch Pin orientation

STEP 2

Insert HITCH PIN through hole in HITCHBOX and hole in TBM SHANK; ensure the LOCATORS are inserted into the NOTCHES in the HITCHBOX (Fig. 3).

STEP 3

Screw HITCH PIN NUT onto HITCH PIN ; tighten HITCH PIN NUT until finger tight, ensuring TBM is restrained from movement.

STEP 4

Tighten HITCH PIN NUT by turning nut a further 1/8th of a turn in the clockwise direction using a 24mm spanner (Fig. 4).

STEP 5

Install HITCH PIN R CLIP through the hole on the HITCH PIN (Fig. 1).

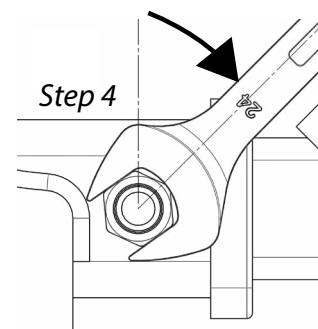

Fig 4. Tightening of Silent Anti-Rattle Hitch Pin Nut