



TOWBAR INSTALLATION INSTRUCTIONS

PART NUMBER QTDS863L

NISSAN PATROL Y62 CL4

PRODUCT DETAILS:

Part Number:	QTDS863L	Maximum Towing Braked:	3500	kg
ECU Number:	N/A	Maximum Towing Unbraked:	750	kg
Tail Harness Length Required:	1800mm	Maximum Static Ball Load:	350	kg
TBM/Lug Part Number:	21325			

FITTING DETAILS:

Towbar Installation Time:	100 Mins.	RPA Disable/Other:	NO
Total Installation Time:	140 Mins.		
Bumper Cut Required:	Yes		

Note:

- RPA is disabled by pressing "PMOD" on infotainment screen.

TRAILBOSS RECOMMENDS THAT INSTRUCTIONS ARE READ AND UNDERSTOOD COMPLETELY PRIOR TO FITMENT.

BEFORE YOU START:

Check all hardware items have been included refer to assembly diagram.
Please ensure this towbar is only fitted to vehicle models as per Trailboss application guide.

Bumper Cuts

Vehicle and bumper variations can and do occur during vehicle manufacture after initial towbar design. Fitment of towbar to vehicle and accuracy of bumper cut must be assessed prior to any bumper modifications made. Incorrect bumper cuts are not covered under Trailboss warranty.

NOTE: Bumper cuts need to be approached with care, refer to notes below.

- Bumper centreline – where the centreline of the bumper needs to be determined, the installer must assess centre point by measurement of bumper width or determining two symmetrical reference points to give centreline.
- Bumper edge – To assist with accurate bumper cut measurement, reference to the start of the bumper edge is now being commonly used.
 - Measure from bottom edge along bumper and around corner to the 70 mm point (Figure 1).
 - Do not measure from visible bumper front of corner, upwards (Figure 2).

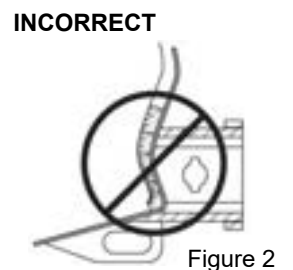
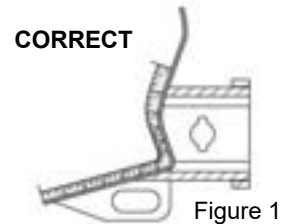

Drilling

- For any required drilling during installation, ensure that the area is clear of fuel, electrical & other components that may be damaged.
- All holes drilled into metal body panels shall have all burrs & swarf removed then coated with a suitable rust preventative paint.

Bolts/Fasteners

- Ensure that all hardware is fastened to correct torque as specified in this fitting instruction.
- All fasteners supplied with this product are used to achieve a specified clamp loading. If replacement is required ensure that fasteners of the same grade and class are used.

NOTE: Achieving correct torque is critical to proper installation and responsibility of the installer. Towbar failures attributed to tension issues from over tightening or under tightening are not covered by Trailboss warranty.

Product Labels

- a. Towbar load rating sticker provided with this product shall be conspicuously located on inside rear end of the driver's door.

WARNING:

Do not, drill, cut, weld or otherwise modify the towbar.

FOR TOWING PURPOSES ONLY - This towbar is designed and tested by Trailboss to adhere to ADR 62/02 which provides only for the expected load demands of towing.

i TOWBAR ASSEMBLY DIAGRAM

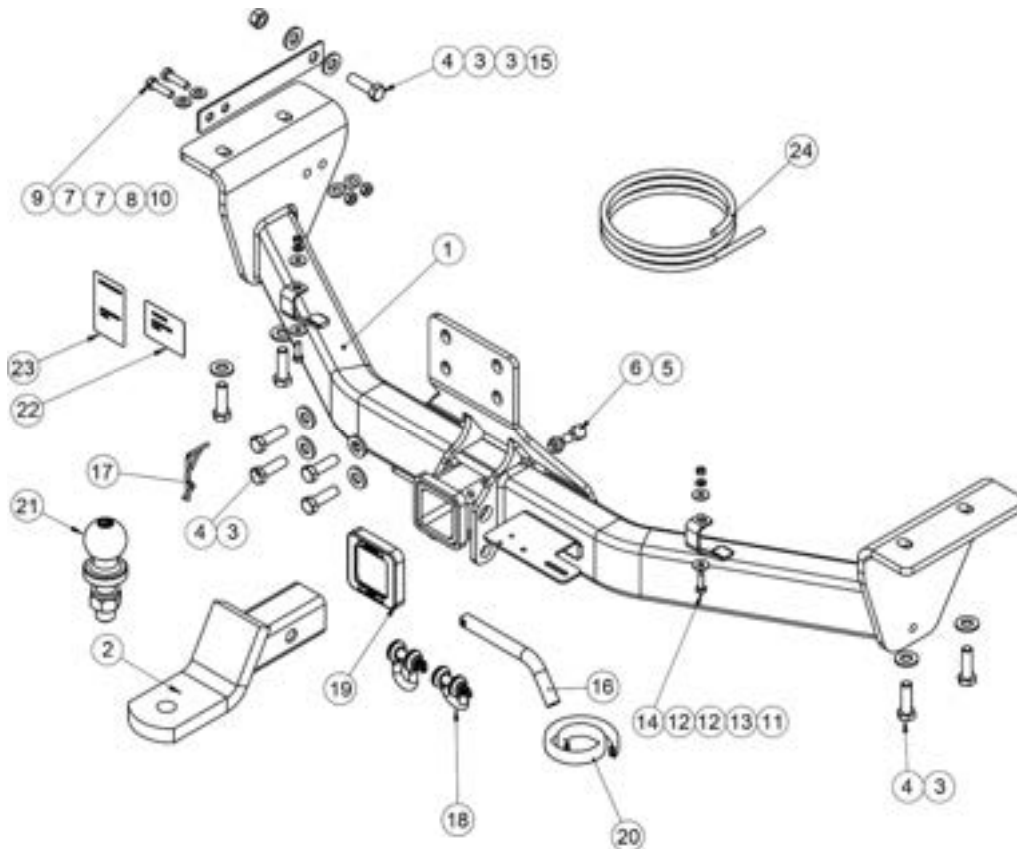

ITEM	DESCRIPTION	QTY
1	NISSAN PRATROL WELDED ASSY	1
2	TRAILER BALL MOUNT	1
3	WASHER FLAT 1/2"x1 1/8"x1/8"	10
4	BOLT HEX HD M12x40x1.25P	9
5	NUT HEX HD M10x1.5P	1
6	BOLT HEX HD M10x25x1.50P	1
7	SUPPORT BRACKET	1
8	WASHER PLAIN M8x19.5x1.6	4
9	BOLT HEX HD M8x30x1.25P	2
10	NUT HEX HD M8x1.25P	2
11	NUT HEX HD M6x1.0P	2
12	WASHER PLAIN 1/4x3/4x16	4

ITEM	DESCRIPTION	QTY
13	WASHER SPRING M6	2
14	SET SCREW HEX HD M6x20x1.0P	2
15	NUT HEX HD M12x1.25P	17
16	PULL PIN	1
17	SPRING COTTER PIN	1
18	"D" SHACKLE 10mm	2
19	HITCH BOX COLLAR COVER	1
20	BUMPER TRIM 950mm	1
21	TOWBALL 50mm	1
22	COMPLIANCE LABEL	1
23	LOAD RATING LABEL	1
24	WIRING LOOM	1

1. Remove 5x Screws from Rear Wheel Mud Flap in the inside of the Wheel Arc for both the LH & RH side. Also remove 1x Screw located behind the Mud Flap on the underside of the Bumper.

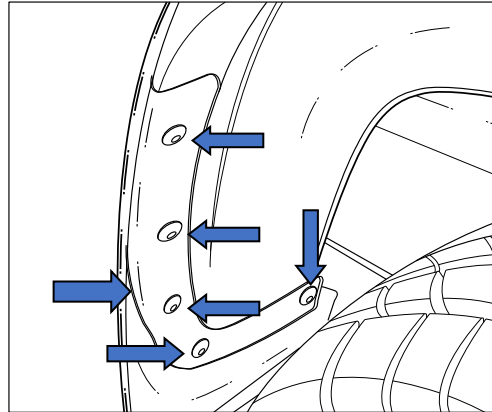

2. Remove 4x Bolts from the underside of the Bumper Bar for both the LH&RH side.

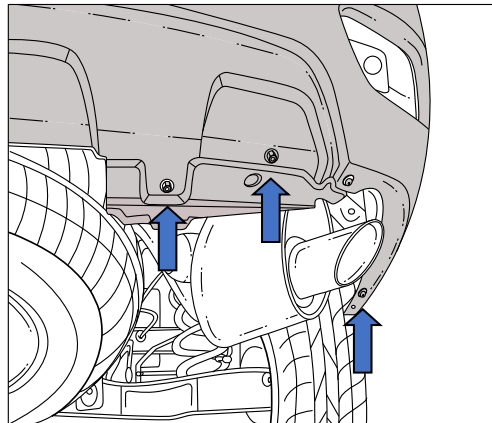

3. Open Rear Boot Door and remove Plastic Side Covers from the Rear Lights and remove the 2x Bolts from Rear Light for both the LH & RH side.

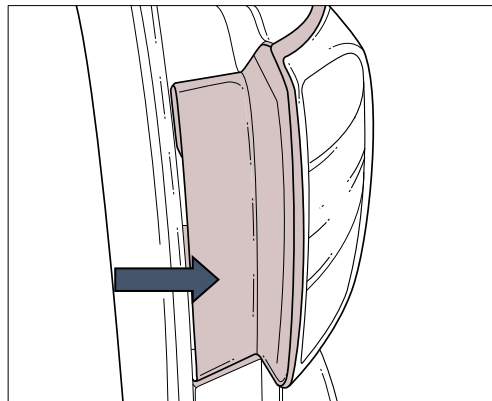

- Note the Rear Lights have plastic pins located on their sides, therefore for removal of the Rear Lights, they must be firmly pushed outwards to the side to release from side Clips.

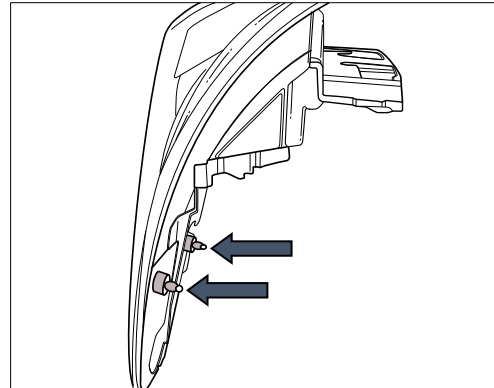

- Remove 1x Bolt and 1x Scrivet located behind the Rear Lights for both the LH&RH side. Then pull firmly on bar to release from Clips.

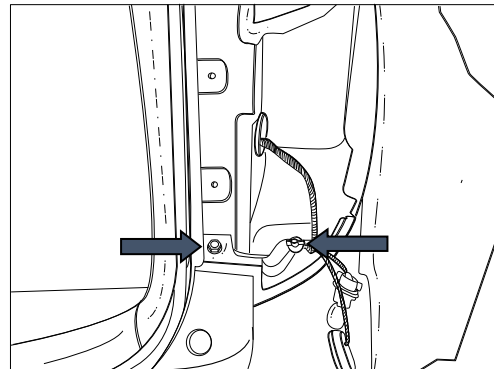

- Remove from both sides all Bumper Tubs and shipping Hook.
Offer Towbar to Vehicle and loosely bolt it in.

Note: Moving the Spare Tire as far forward as possible may be needed.

- Tighten all Bolts to Torque Specifications provided.

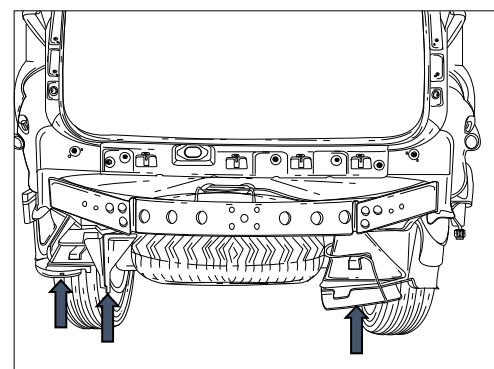

8. Driver side underside Cover/Bumper Tub Mount is required to be cut as to fit around the Towbar but keeping two of the 3 Bumper Tub Mounting Points as shown.

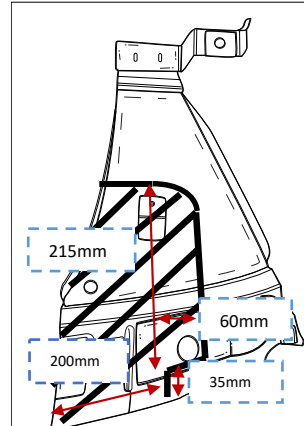

9. Create a Bumper Cut as shown following the outer contours of the two lower Bumper depressions. Installer discretion to be used in covering the cut with Pinch Weld.

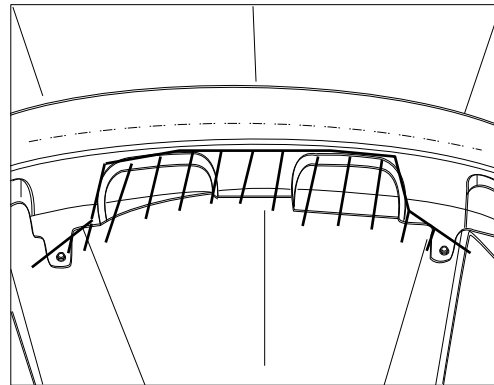

10. Install the replacement passenger underside Cover/Bumper Tub Mount Bracket and attach underside cover to it.

11. Reassemble Vehicle in reverse order to disassembly.

12. In the luggage compartment remove the 2x anchor points.
13. Lift the tool lid cover and remove the tool tray.

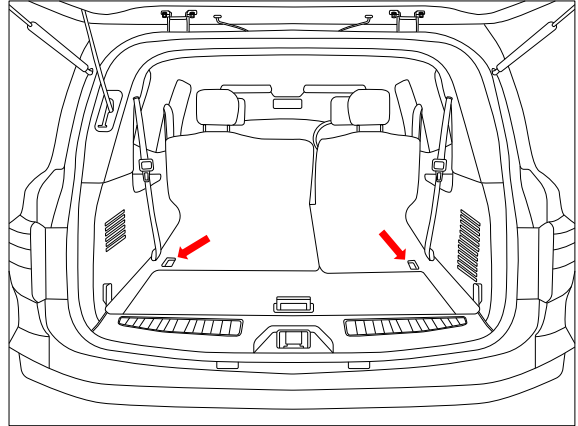

14. Remove the 2x bolts for both LHS and RHS plastic trims and remove the trims.
15. Remove the 2x bolts that secures the straps for the tool lid cover
16. Remove the rear sill trim.
17. Fold the LHS second row seat forward.

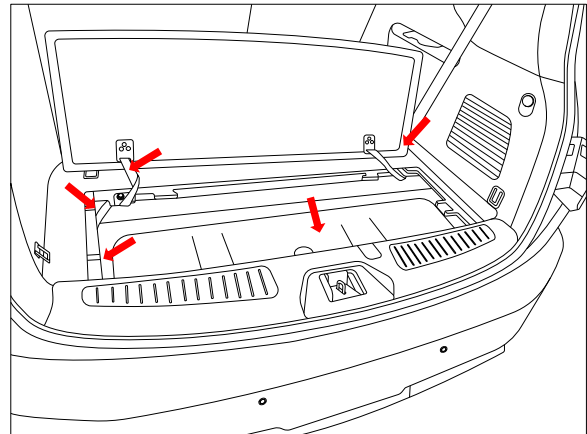

18. Remove the bolt holding both LHS Rear Passenger Seat belts.
19. Remove the LHS rear cargo hooks.
20. Carefully dislodge LHS trim and the disconnect the 2-way AUX connector.
21. Remove the LHS trim.

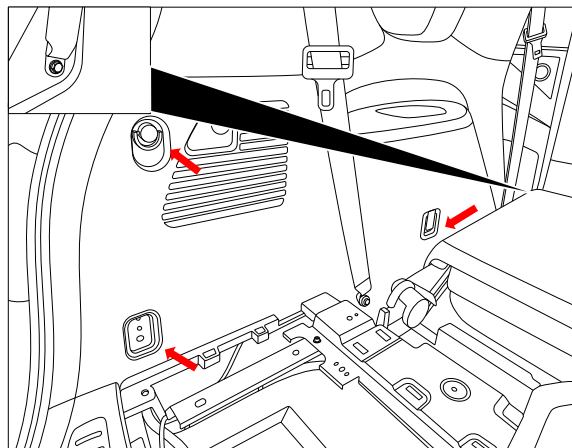

22. Drill a $\varnothing 30\text{mm}$ hole in the area indicated.



IMPORTANT:

Look underneath prior to drilling. Ensure that hole is clear of the spare tyre and wiring. Remove all sharp edges and apply rust inhibitor.

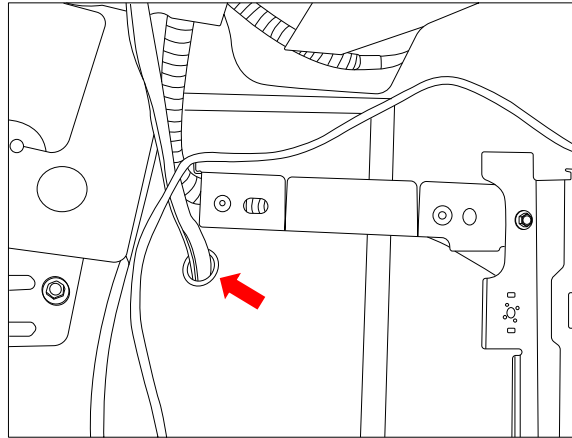

23. Mount the tail (1800mm) to the plug bracket using M4 fasteners (not supplied), route the tail towards the previous drilled hole and feed the blue connector through the hole.

24. Slide the grommet to desired location and secure with cable tie

Keep harness routing away from sharp edges moving parts and places of extreme heat.

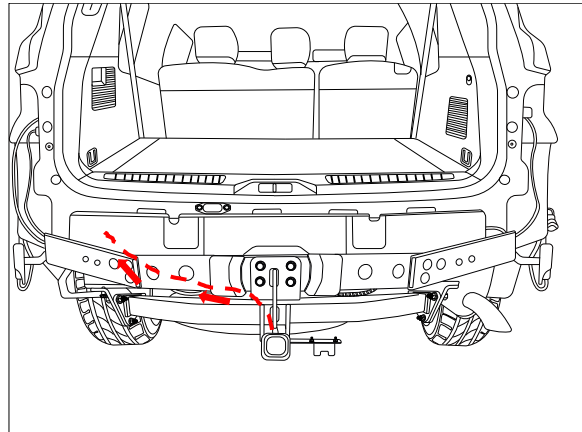

25. Locate the 6-way Pre-wire connector at the front of the LHS wheel arch.

26. Remove the tape securing the Pre-wire connector and patch the trailer patch 102487-WL into the mating connector.

27. Connect the ground ring terminal to the vehicle factory ground point. Route the trailer patch towards the previously ran tail harness blue connector rear for the vehicle following the main vehicle harness.

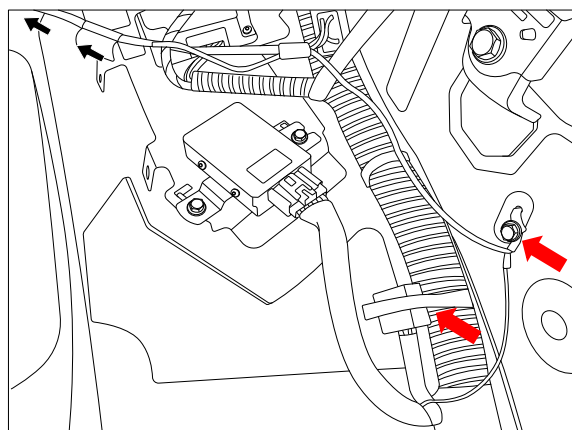

-
28. Connect the tail harness (tail length 1800mm) 8-way connector to the trailer patch mating connector.

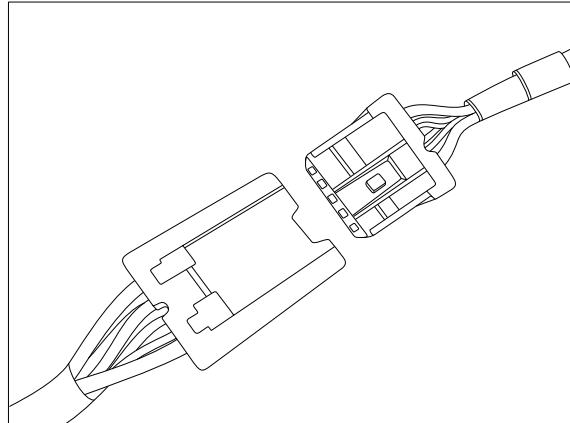

-
29. Reassemble all removed parts and secure all fasteners from steps 1 to 5, and 12 to 21 in reverse ensuring there are no squeaks or rattles.
30. Test the trailer wiring harness function using a light board or multimeter.
31. RPA is disabled by pressing "**Pmod**" on infotainment screen.
32. Place fitting instructions in the glove box after fitment.

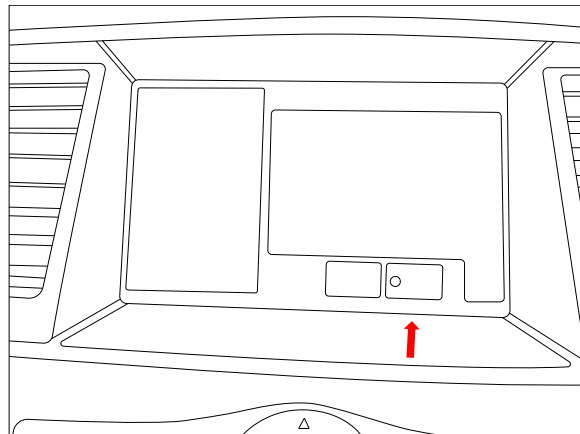



CUSTOMER INFORMATION

PLACE THESE INSTRUCTIONS IN THE
VEHICLE'S GLOVEBOX AFTER INSTALLATION

**HANK YOU FOR PURCHASING TRAILBOSS. WITH CORRECT MAINTENANCE AND CARE
THIS PRODUCT WILL PROVIDE A LIFETIME OF TROUBLE-FREE OPERATION.**

TOWBAR MAINTENANCE AND CARE:

1. Trailboss recommend that the towbar LUG or TBM (Trailer Ball Mount) Pull Pin and R-clip are removed and stored when not in use. Removal of LUG or TBM (Trailer Ball Mount) is advisable when not in use to assist with any of the following.
 - Ensure rear number plate is not obscured.
 - Allow maximum available departure angle and prevent any potential interference.
 - Prevent possible interference with vehicles reverse sensors or camera detecting a tow ball mount as an obstruction during reversing.
 - Removes towball mount as an obstruction for when moving around the rear of the vehicle.
2. Trailboss recommends routine inspection of your towbar to ensure trouble free towing.
 - Bolt security and tension should be regularly inspected and checked for correct tension. Replace any worn or defective parts with suitable grade & class fasteners. Inspection should be requested to coincide with vehicle major services.
3. It is the owner's responsibility to ensure towing and down ball weight capacities of the towing vehicle are not exceeded.
 - Towing and down ball weights allowable may differ according to model variations. Please refer to owner's manual or vehicle dealer to confirm exact rating for your vehicle model variant.
 - It is not uncommon for the vehicle tow rating to differ from the towbar rating. When this occurs, the lesser rating must be adhered to.
 - For vehicles fitted with enhanced vehicle functions that may be altered/changed when towing i.e Trailer sway mitigation, blind spot detection, adaptive cruise control etc. Please consult owner's manual to understand changes enabled when towing and after towing.

WARRANTY INFORMATION:

Trailboss Towbars are covered by a Lifetime Warranty.

Our goods come with guarantees that cannot be excluded under the Australian Consumer Law. You are entitled to a replacement or refund for a major failure and for compensation for any other reasonably foreseeable loss or damage. You are also entitled to have the goods repaired or replaced if the goods fail to be of acceptable quality and the failure does not amount to a major failure.

For further details please contact customer service on 1800 812 017.

PRO SERIES SILENT ANTI-RATTLE HITCH PIN

Your Trailboss towbar is equipped with a Pro Series Silent Anti-Rattle Hitch Pin technology to help reduce towbar tongue rattle in most driving conditions. Please ensure below instructions are understood and routine maintenance is carried out to ensure best towing experience.

Regularly inspect for wear and check the tightness of the Silent Anti-Rattle Hitch Pin. Follow instructions below to re-tighten the nut as necessary when movement and noise in the tow ball mount is noted.

- Before towing, ensure R-Clip is properly installed and hitch pin nut is installed and tensioned. Replacement parts are available from your Pro Series Distributor.

TOWBALL MOUNT REMOVAL/INSTALLATION

STEP 1

Insert Trailer Ball Mount (TBM) (a) into towbar hitchbox (b), aligning hole in TBM shank (c) with hole in hitchbox (d) (Fig. 1)

STEP 2

Insert Silent Anti-Rattle Hitch Pin (e) through hole in hitchbox and hole in TBM shank (g); ensure the locators are inserted into the notches in the hitchbox (Fig. 2)

STEP 3

Screw Silent Anti-Rattle Hitch Pin Nut (f) onto Smart Pin (g); tighten Smart Pin Nut until finger tight, ensuring TBM is restrained from up and down movement.

STEP 4

Tighten Silent Anti-Rattle Hitch Pin Nut by turning nut a further 1/8th of a turn in the clockwise direction using a 24mm spanner (Fig. 4).

STEP 5

Install Silent Anti-Rattle Hitch Pin R-Clip through the hole that provides best clearance or easiest access. (Fig. 5)

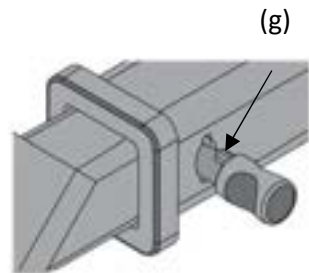
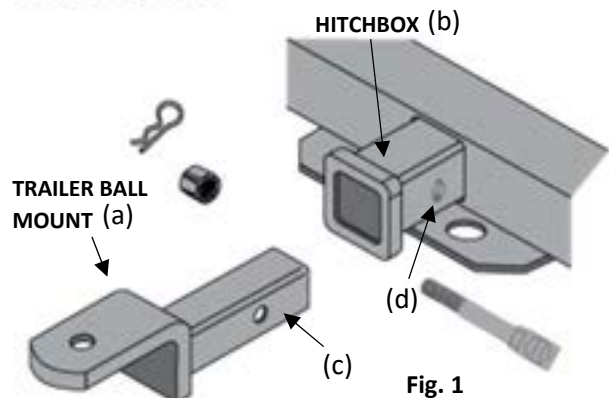

Fig. 2

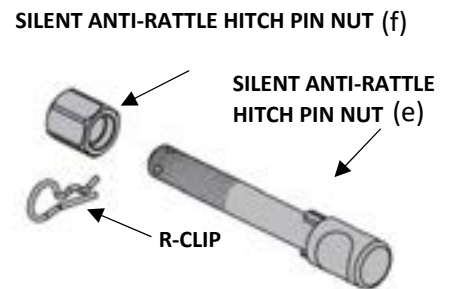

Fig. 3

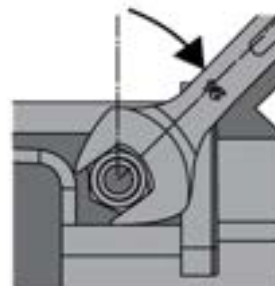

Fig. 4

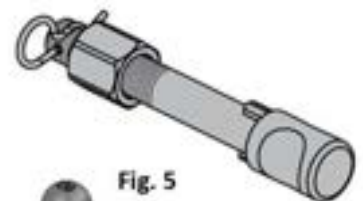

Fig. 5

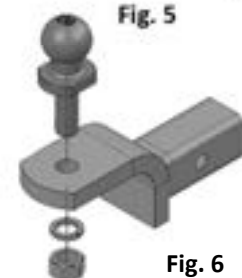

Fig. 6