



Towbar Fitting Instructions
To Suit Ford BA & BF Fairlane 07/03-on
Part Number QTFD1410
Rating 2300kg

WARNING:

1. Do not, drill, cut, weld or otherwise modify the tow bar.
2. If you are using electric welding on a motor vehicle, **always** check that the vehicle is not equipped with electronic engine or instrument management equipment. Failure to do so could **destroy** any onboard computers. If in doubt, check with the vehicle's manufacturer.

1. Ensure all hardware items have been included
2. Remove bumper via.
 - (a) Remove 3 plastic trim buttons and 1 self-taping screw from each wheel arch.
 - (b) Remove 3 plastic trim buttons from spear wheel well.
 - (c) Remove plastic trim buttons from rear ¼ trim and fold forward.
 - (d) Remove 2 x 5mm nuts from below tail light assemblies.
 - (e) Remove bumper.
3. Remove two rear most pop rivets from heat shield to gain access to side of sub frame.
4. Cut rear panel & impact beam as per Figs 1& 3 and coat with anti rust paint.
5. Mark then drill driver side chassis rail as per fig 2 with 11mm drill bit.
6. Temporarily fit tow bar using one taptite bolt per side.
7. Mark and drill two 11mm hole in passenger side arm.
8. Mark and drill 11mm hole for vertical holes in cross tube on passenger side.
9. Mark and drill two horizontal 12.5mm holes through driver side arm.
10. Using loose plate with Ø14 holes align with holes drilled in step 5 & 7 and hold in place with masking tape or similar making sure that passenger side loose plate is between side arm & sub frame.
11. Fit remaining bolts, nuts flat & spring washers with bolt on chassis plate to the inside of the chassis rail then tighten to torque listing below.
12. Refit bumper in reverse of step 2 E to A.
13. Refit exhaust heat shield with pop rivets supplied.
14. Note electrical trailer plug to be mounted on under side of bumper or a hang out of boot type.
15. Bar is shipped with chassis plate fastened to the bar with M10 nuts and bolts, these nuts & bolts are to be discarded.

RECOMMENDED ASSEMBLY TORQUE LISTING

Diameter Grade 8.8 Bolt

	Nm;
M6	9.5
M8	21.7
M10	43.4
M12	77.3
M16	189.8

FOR TOWING PURPOSES ONLY
For towing capacity details please refer to vehicle owner's manual or to the manufacturer. Overloading can void your warranties.

TRAILBOSS

Towbar Fitting Instructions
To Suit Ford BA & BF Fairlane 07/03-on
Part Number QTFD1410
Rating 2300kg

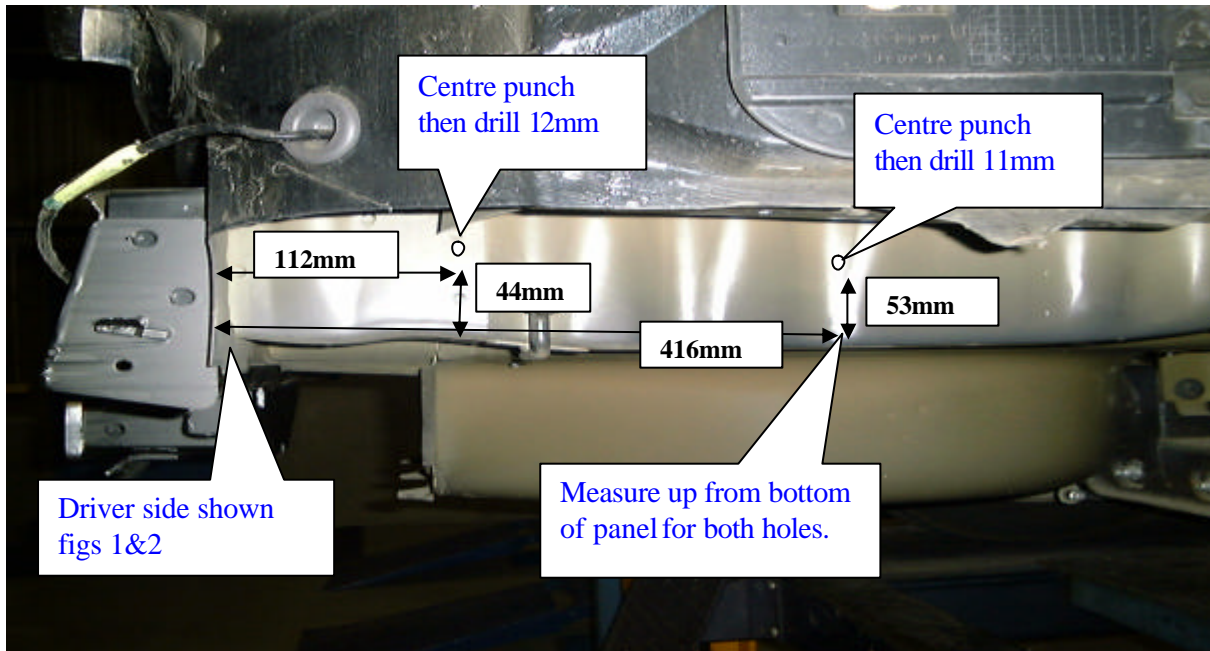
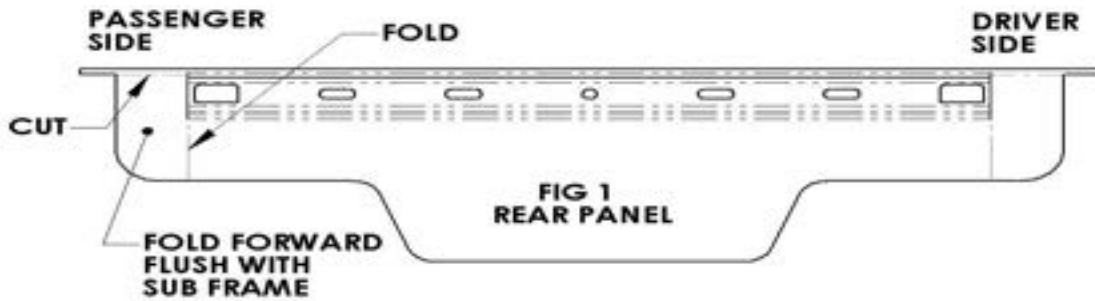
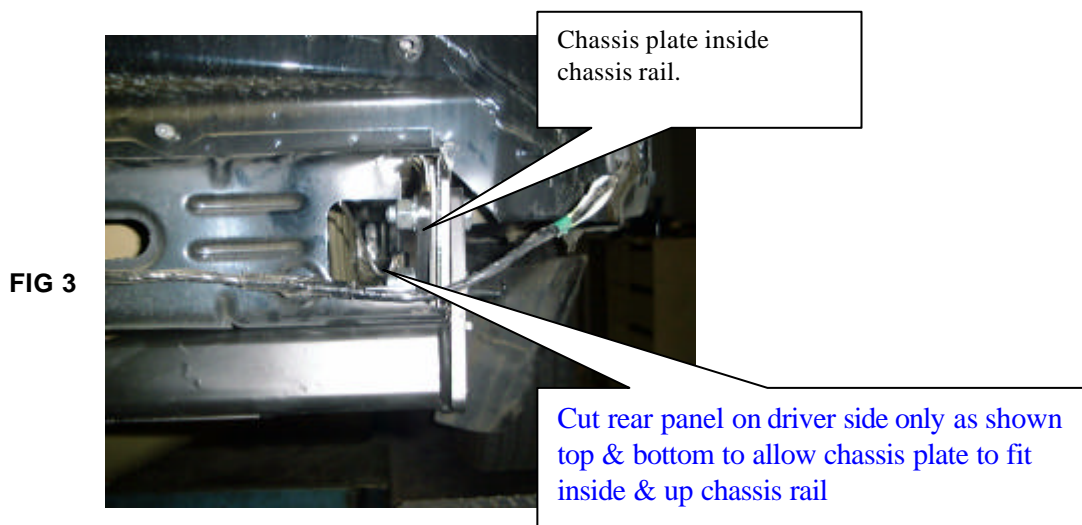

FIG 2



TRAILBOSS

Towbar Fitting Instructions
 To Suit Ford BA & BF Fairlane 07/03-on
 Part Number QTFD1410
 Rating 2300kg

