

PRODUCT DETAILS:

Part Number:	QTFD1918L	Maximum Towing Braked:	1800	kg
ECU Number:	04826	Maximum Towing Unbraked:	750	kg
Tail Harness Length Required:	1800 mm.	Maximum Static Ball Load:	180	kg
TBM/Lug Part Number:	21379			

FITTING DETAILS:

Towbar Installation Time:	90 Mins.	RPA Disable/Other:	NO
Total Installation Time:	135 Mins.		
Bumper Cut Required:	Yes		

Note:

- RPA disable can be accessed via the Infotainment unit.

TRAILBOSS RECOMMENDS THAT INSTRUCTIONS ARE READ AND UNDERSTOOD COMPLETELY PRIOR TO FITMENT.

BEFORE YOU START:

Check all hardware items have been included refer to assembly diagram.
Please ensure this towbar is only fitted to vehicle models as per Trailboss application guide.

Bumper Cuts

Vehicle and bumper variations can and do occur during vehicle manufacture after initial towbar design. Fitment of towbar to vehicle and accuracy of bumper cut must be assessed prior to any bumper modifications made. Incorrect bumper cuts are not covered under Trailboss warranty.

NOTE: Bumper cuts need to be approached with care, refer to notes below.

- Bumper centreline – where the centreline of the bumper needs to be determined, the installer must assess centre point by measurement of bumper width or determining two symmetrical reference points to give centreline.
- Bumper edge – To assist with accurate bumper cut measurement, reference to the start of the bumper edge is now being commonly used.
 - Measure from bottom edge along bumper and around corner to the 70 mm point (Figure 1).
 - Do not measure from visible bumper front of corner, upwards (Figure 2).

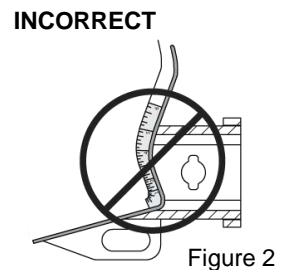
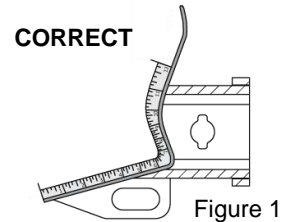

Drilling

- For any required drilling during installation, ensure that the area is clear of fuel, electrical & other components that may be damaged.
- All holes drilled into metal body panels shall have all burrs & swarf removed then coated with a suitable rust preventative paint.

Bolts/Fasteners

- Ensure that all hardware is fastened to correct torque as specified in this fitting instruction.
- All fasteners supplied with this product are used to achieve a specified clamp loading. If replacement is required ensure that fasteners of the same grade and class are used.

NOTE: Achieving correct torque is critical to proper installation and responsibility of the installer. Towbar failures attributed to tension issues from over tightening or under tightening are not covered by Trailboss warranty.

Product Labels

- a. Towbar load rating sticker provided with this product shall be conspicuously located on inside rear end of the driver's door.

WARNING:

Do not, drill, cut, weld or otherwise modify the towbar.

FOR TOWING PURPOSES ONLY - This towbar is designed and tested by Trailboss to adhere to ADR 62/02 which provides only for the expected load demands of towing.

i TOWBAR ASSEMBLY DIAGRAM

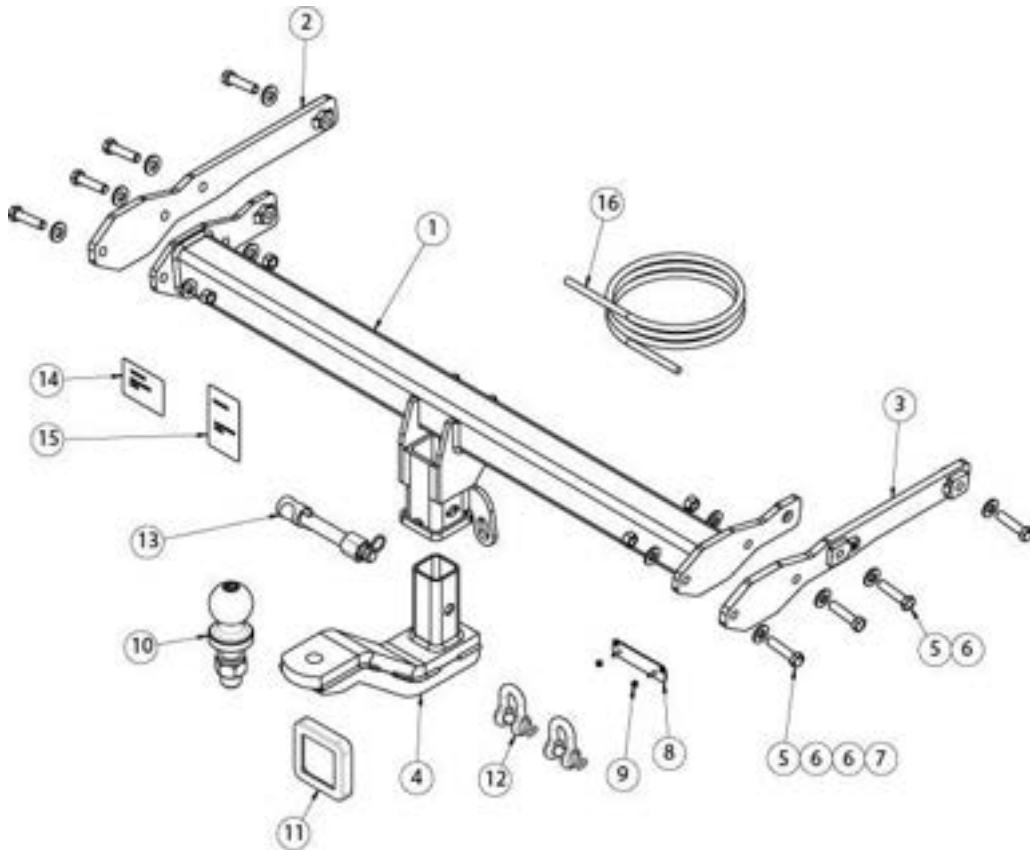

ITEM	DESCRIPTION	QTY
1	FORD ESCAPE WELDED ASSY	1
2	SIDE ARM ASSEMBLY LH	1
3	SIDE ARM ASSEMBLY RH	1
4	TRAILER BALL MOUNT	1
5	BOLT HEX HD M12x50x1.75P	8
6	WASHER PLAIN 1/2"	12
7	NUT HEX HD M12x1.75P	4
8	PLUG BRACKET	1
9	NUT NYLOC HEX HD M4x0.7P	2
10	TOWBALL 50mm	1
11	HITCH BOX COLLAR COVER	1
12	"D" SHACKLE 10mm	2
13	SMART PIN SILVER	1
14	COMPLIANCE LABEL	1
15	LOAD RATING LABEL	1
16	WIRING LOOM	1

-
1. In wheel arch, remove 5 x scrivets.

Repeat for other side.

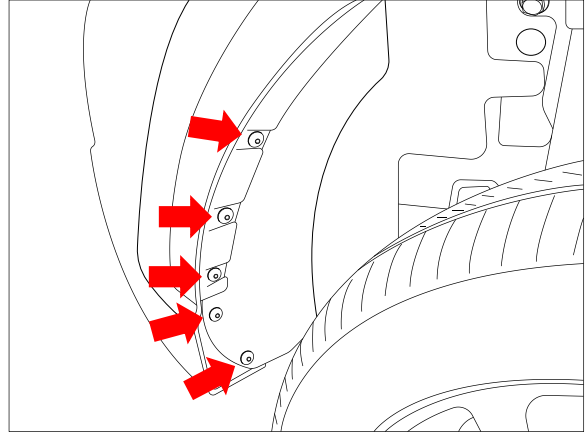

-
2. Peel away wheel arch skirting (2 x plastic clips) to reveal 1 x scrivet and remove the scrivet.

Repeat for other side.

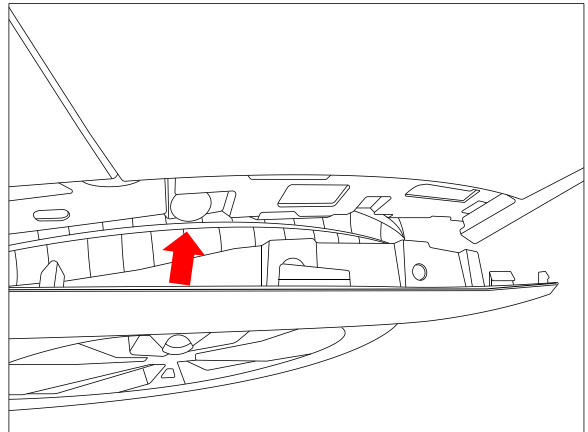

-
3. Open the tailgate.
 4. Remove cover and remove 1 x screw securing the taillight.

Repeat for other side

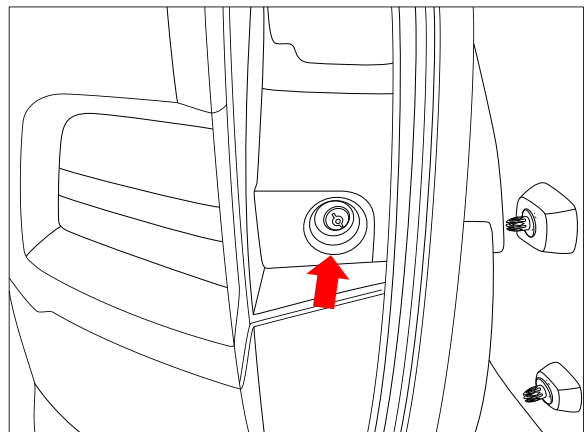

5. On the rear tailgate sill trim locate and remove the 2x scrivenets.
6. Release the 2x covers on the cargo hooks to expose the fasteners, then remove.
7. Dislodge and remove the sill trim.

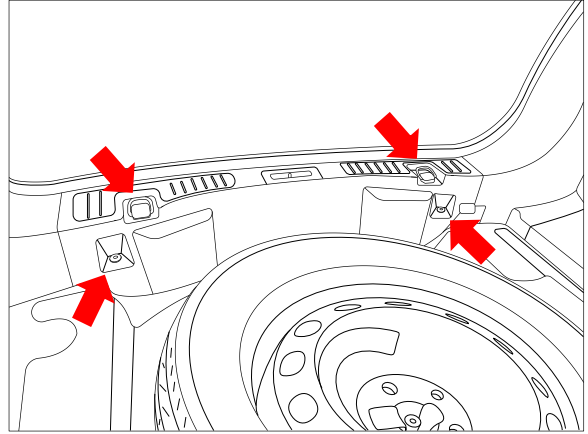

8. Unclip the bottom plastic cover and peel away the side trim to reveal the taillight harness connector.

Repeat for other side.

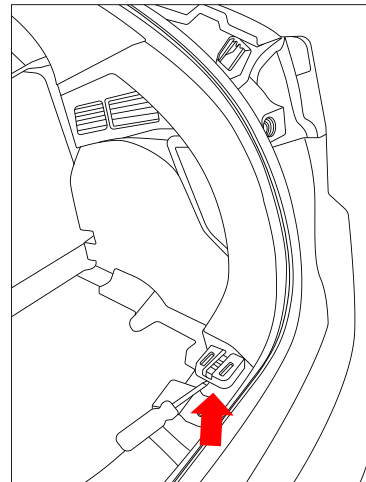

9. Disconnect the taillight connector and remove taillight.

Repeat for other side.

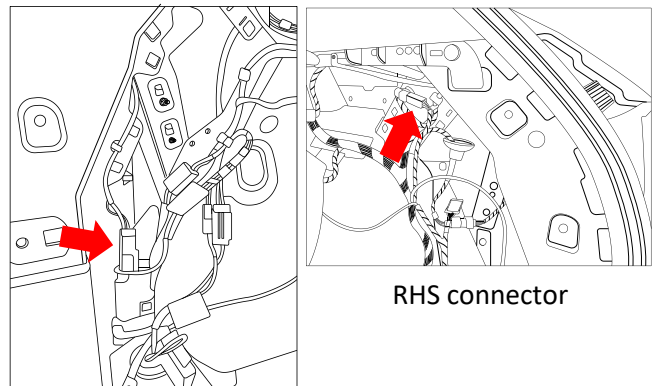

LHS connector

RHS connector

-
10. Under vehicle remove 1 x scrivet and 2 x hex screws.

Repeat for other side.

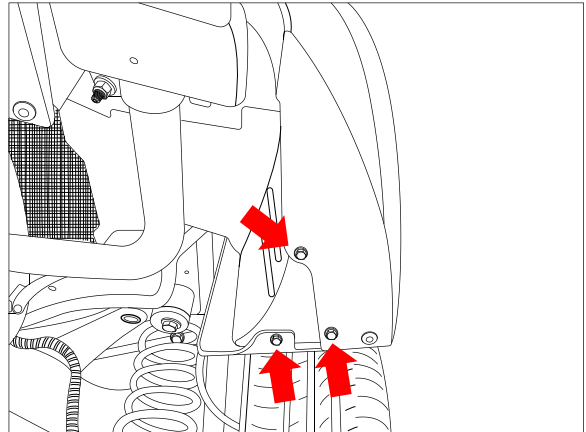

-
11. Under bumper remove 4 x scrivets and 4 x hex screws.

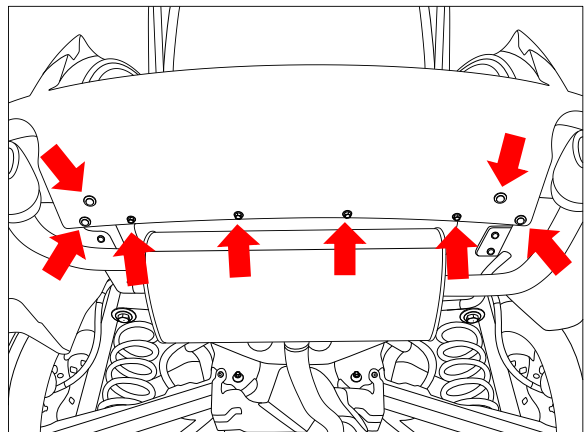

-
12. Peel bumper away from the sides and remove from vehicle.

13. Remove plastic bumper support secured with 6 x hex screws and a centre clip.

14. Remove and discard the impact beam secured with 4 x nuts per side.

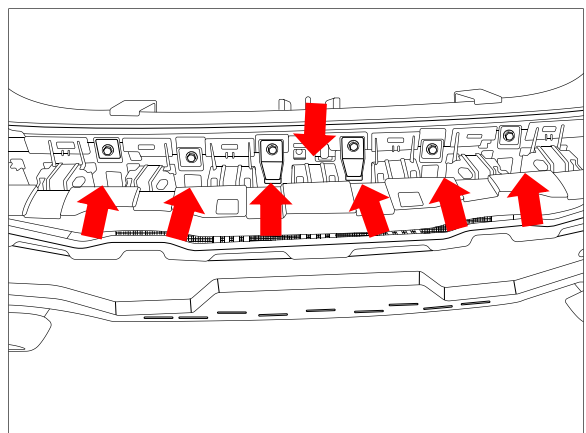

15. Insert side arm into the chassis rail and loosely secure the most forward (of vehicle) mounting position with 1 x M12 bolt complete with 1 x washer.

Ensure that the welded-on spacer plates on the side arms are facing outwards of the vehicle and that the orientation of the side arm is correct. Repeat for other side.

NOTE: An add blue tank may have to be loosened on some models to gain access to the bolt holes required for steps 15 and 16.

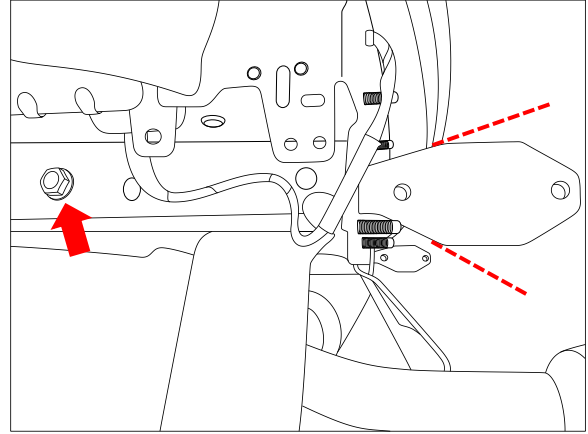

16. Position the crosstube on the side arms and secure the most forward mounting position (of crosstube) with 1 x M12 bolt complete with 1 x washer and the remaining 2 positions with 1 x M12 bolt complete with 2 x washers and 1 x nut per bolt.

17. Position the bar and tighten all the fasteners to the following torques:

M12 x 1.75 Gr10.9 : 109Nm

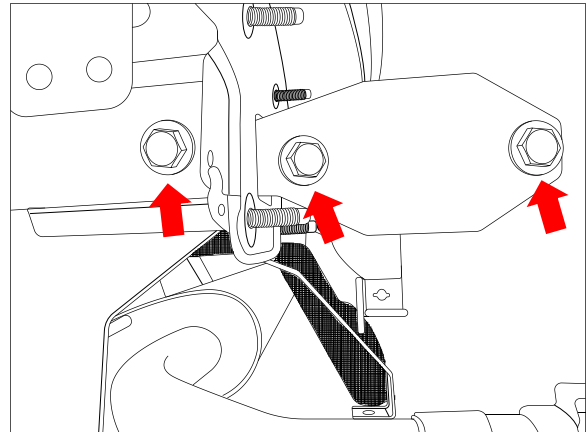

18. For the heatshield cut.

Determine the centre of the heatshield, mark off 350mm wide x 50 mm high as measured from the bottom edge of the heatshield and cut only the solid end lines (refer to image).

Fold the section backwards on itself (along the dotted line) to prevent a sharp edge as this cut out is to gain access to the smartpin and safety chain shackle once the bumper is fitted.

NOTE: Check smartpin accessibility and clearance once the bumper is refitted.

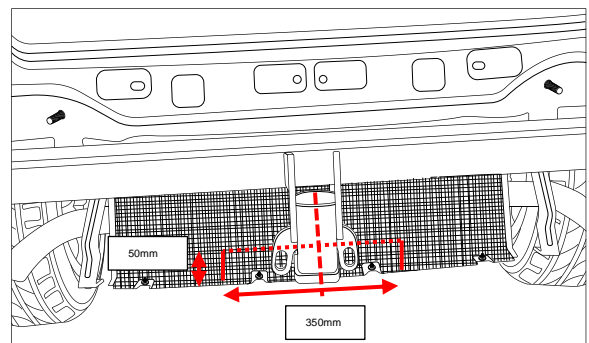

19. For Bumper cut.

Unclip a centre section of the foot sensor from its position and move it away from the clip. Determine the centre of the bumper, measure, mark off and cut out a trapezium section 180/90mm wide and 75mm long, measured from the bottom edge of the bumper. Both the bumper and the sensor bracket must be cut.

Ensure to not cut through or damage the foot swipe cable located on the inside of the bumper.

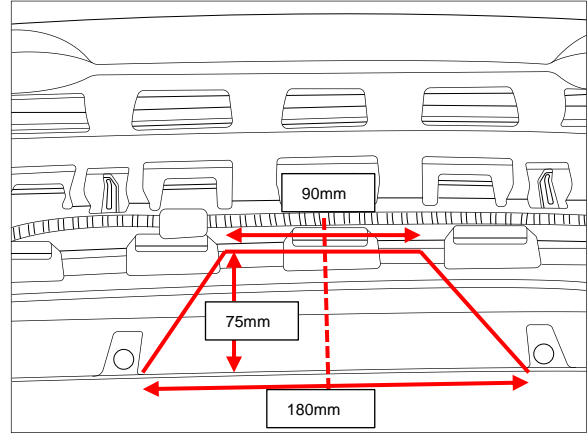

20. At an appropriate position on the bumper, mark out and drill 2x ø5mm holes 69mm apart on bumper skin to support plug bracket. Feed bracket threads through drilled holes prior to reinstalling bumper.

Be careful not to cut through or damage the foot swipe cable located on the inside of the bumper.

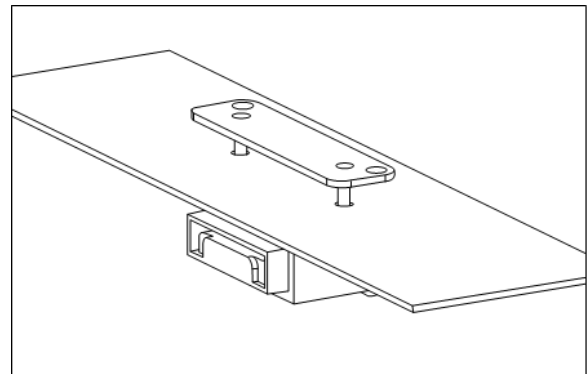

IMPORTANT

Due to possible vehicle variations, always confirm any noted vehicle colour wires with a multi-meter to ensure the correct function is identified before soldering or scotch locking. For vehicle wires denoted with two colours (example; RED/GREEN) the first colour will always be the main wire colour while the second colour is the thinner trace colour on the wire.

21. On the inside RHS rear corner of the luggage compartment, drill a Ø30mm hole.
22. File any rough or sharp edges and spray with rust inhibitor.

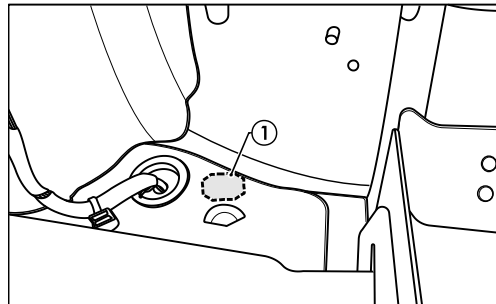

23. At the LHS branch on the patch harness (101639-WL) house the female terminal:
 - Yellow/Black wire into position 3
 - White wire into position 6

Note: Connector rear view.

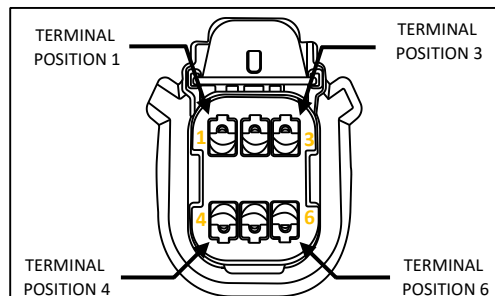

24. At the LHS branch on the patch harness house the male terminal:

- Yellow/Black wire into position 3
- White wire into position 6

Note: Connector rear view.

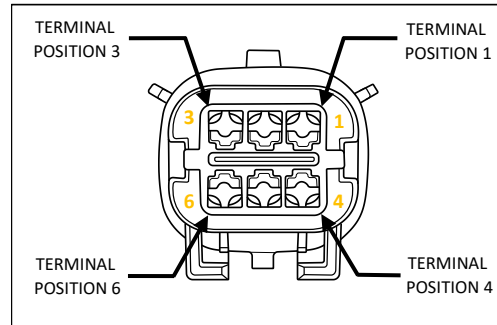

25. At the RHS branch on the patch harness house the female terminal:

- Green/Black into position 3
- Red/Black into position 2
- Brown/Black into position 1
- White wire into position 6

Note: Connector rear view.

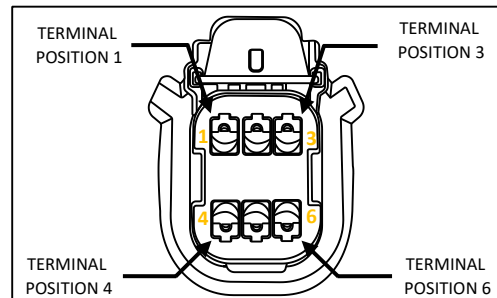

26. At the RHS branch on the patch harness house the male terminal:

- Green/Black into position 3
- Red/Black into position 2
- Brown/Black into position 1
- White wire into position 6

Note: Connector rear view.

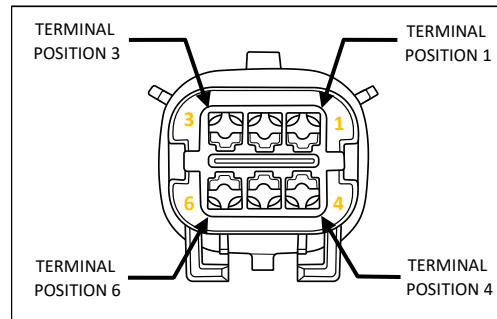

27. At the LHS tail lamp, patch in the LHS tail lamp connectors on the patch harness in between the vehicle taillight wiring (1) and the vehicle body wiring (2).

28. Connect the power extension wire to the grey vehicle pre-wire connector (3).

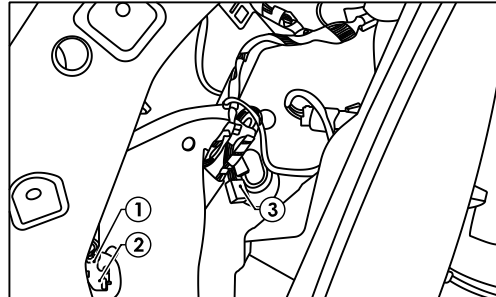

29. Route both harnesses across to the RHS of the vehicle.

30. On the RHS, patch in the RHS patch connectors in between the vehicle tail light wiring and the vehicle body wiring.

31. Connect the 1-way connector on the power extension wire to the 1-way connector on the trailer patch and secure excess length.

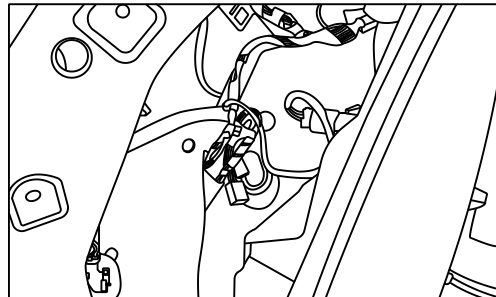

32. Inside the RHS luggage compartment, apply double sided tape to the ECU (1) and secure it to the vehicle sheet metal in the area shown.

33. Connect the trailer patch 12-way connector (2) to the ECU.

Note: Ensure ECU connector is facing downwards.

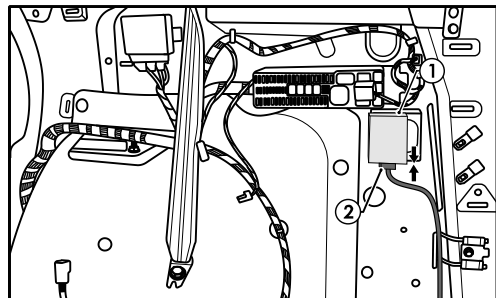

-
34. Secure the trailer patch ground ring terminal (1) to the existing vehicle grounding point (2) in the upper RHS area.

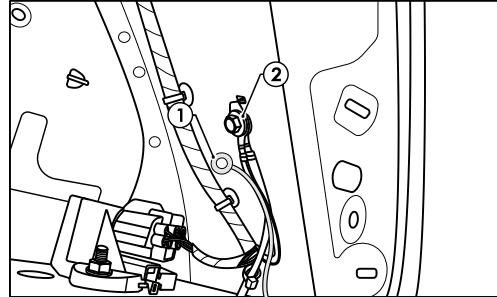

-
35. Mount the trailer socket (1) to the tow bar mounting bracket using M4 fasteners (not supplied).
36. Route the tail harness (2) across the tow bar towards the RHS of the vehicle and up through the previously drilled out hole.
37. Ensure the tail harness grommet is seated correctly and secure in place using a cable tie (supplied).

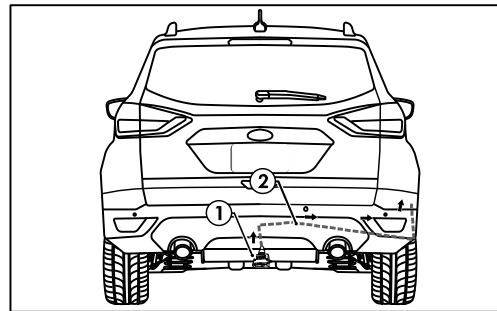

-
38. Connect the tail harness (tail length 1800mm) 8-way connector (1) to the trailer patch mating 8-way connector (2).

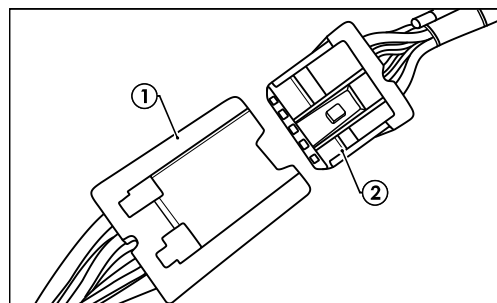

-
39. The RPA function can be disabled by a switch near the transmission knob.
 40. Test the trailer patch function using a light board or multi meter.
 41. Secure all harnesses using cable ties (not supplied).
 42. Refit the bumper and removed components following steps 1 to 13 in reverse and ensure there are no squeaks or rattles.
 43. Place the fitting instructions in the glove box after fitment.
-



CUSTOMER INFORMATION

PLACE THESE INSTRUCTIONS IN THE
VEHICLE'S GLOVEBOX AFTER INSTALLATION

**THANK YOU FOR PURCHASING TRAILBOSS. WITH CORRECT MAINTENANCE AND CARE
THIS PRODUCT WILL PROVIDE A LIFETIME OF TROUBLE-FREE OPERATION.**

TOWBAR MAINTENANCE AND CARE:

1. Trailboss recommend that the towbar LUG or TBM (Trailer Ball Mount) Pull Pin and R-clip are removed and stored when not in use. Removal of LUG or TBM (Trailer Ball Mount) is advisable when not in use to assist with any of the following.
 - Ensure rear number plate is not obscured.
 - Allow maximum available departure angle and prevent any potential interference.
 - Prevent possible interference with vehicles reverse sensors or camera detecting a tow ball mount as an obstruction during reversing.
 - Removes towball mount as an obstruction for when moving around the rear of the vehicle.
2. Trailboss recommends routine inspection of your towbar to ensure trouble free towing.
 - Bolt security and tension should be regularly inspected and checked for correct tension. Replace any worn or defective parts with suitable grade & class fasteners. Inspection should be requested to coincide with vehicle major services.
3. It is the owner's responsibility to ensure towing and down ball weight capacities of the towing vehicle are not exceeded.
 - Towing and down ball weights allowable may differ according to model variations. Please refer to owner's manual or vehicle dealer to confirm exact rating for your vehicle model variant.
 - It is not uncommon for the vehicle tow rating to differ from the towbar rating. When this occurs, the lesser rating must be adhered to.
 - For vehicles fitted with enhanced vehicle functions that may be altered/changed when towing i.e Trailer sway mitigation, blind spot detection, adaptive cruise control etc. Please consult owner's manual to understand changes enabled when towing and after towing.

WARRANTY INFORMATION:

Trailboss Towbars are covered by a Lifetime Warranty.

Our goods come with guarantees that cannot be excluded under the Australian Consumer Law. You are entitled to a replacement or refund for a major failure and for compensation for any other reasonably foreseeable loss or damage. You are also entitled to have the goods repaired or replaced if the goods fail to be of acceptable quality and the failure does not amount to a major failure.

For further details please contact customer service on 1800 812 017.

PRO SERIES SILENT ANTI-RATTLE HITCH PIN

Your Trailboss towbar is equipped with a Pro Series Silent Anti-Rattle Hitch Pin technology to help reduce towbar tongue rattle in most driving conditions. Please ensure below instructions are understood and routine maintenance is carried out to ensure best towing experience.

Regularly inspect for wear and check the tightness of the Silent Anti-Rattle Hitch Pin. Follow instructions below to re-tighten the nut as necessary when movement and noise in the tow ball mount is noted.

- Before towing, ensure R-Clip is properly installed and hitch pin nut is installed and tensioned. Replacement parts are available from your Pro Series Distributor.

TOWBALL MOUNT REMOVAL/INSTALLATION

STEP 1

Insert Trailer Ball Mount (TBM) (a) into towbar hitchbox (b), aligning hole in TBM shank (c) with hole in hitchbox (d) (Fig. 1)

STEP 2

Insert Silent Anti-Rattle Hitch Pin (e) through hole in hitchbox and hole in TBM shank (g); ensure the locators are inserted into the notches in the hitchbox (Fig. 2)

STEP 3

Screw Silent Anti-Rattle Hitch Pin Nut (f) onto Smart Pin (g); tighten Smart Pin Nut until finger tight, ensuring TBM is restrained from up and down movement.

STEP 4

Tighten Silent Anti-Rattle Hitch Pin Nut by turning nut a further 1/8th of a turn in the clockwise direction using a 24mm spanner (Fig. 4).

STEP 5

Install Silent Anti-Rattle Hitch Pin R-Clip through the hole that provides best clearance or easiest access. (Fig. 5)

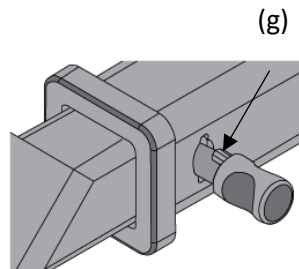
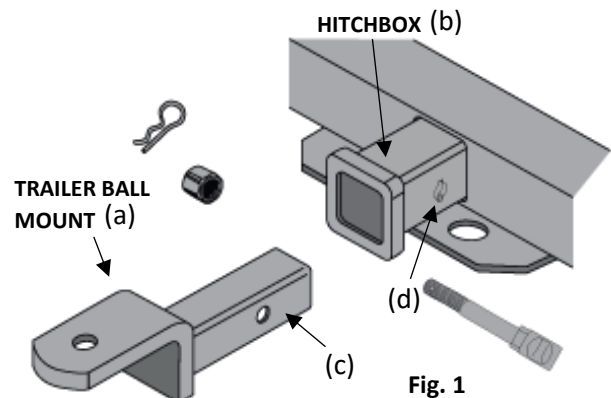

Fig. 2

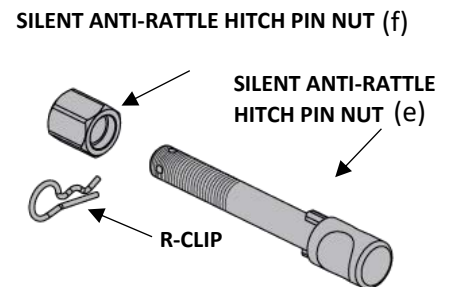

Fig. 3

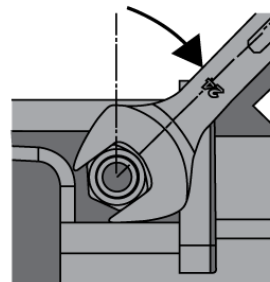

Fig. 4

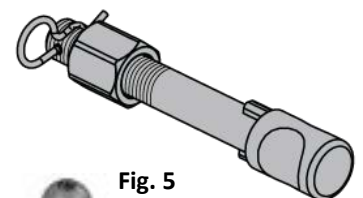

Fig. 5

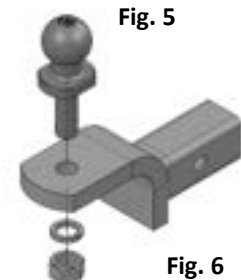

Fig. 6