

TRAILBOSS

Tow bar Fitting Instructions To Suit Ford Ute AU, BA, BF & FG (TUB BODY) XR6 & XR8 Only Part Number QTFD962L Rating 2300 kg Max Static Ball Load 230Kg

WARNING:

1. Do not, drill, cut, weld or otherwise modify the tow bar.
2. If you are using electric welding on a motor vehicle, **always** check that the vehicle is not equipped with electronic engine or instrument management equipment. Failure to do so could **destroy** any onboard computers. If in doubt, check with the vehicle's manufacturer.

General:

1. Ensure all hardware items have been included refer to assembly diagram.
2. It is recommended that the instructions are read through and completely understood before making any attempt to fit this product.
3. Be wary of any changes to vehicle designs or other accessories that may conflict with the installation of this product.
4. Before drilling ensure that the area is clear of fuel, electrical & other components.
5. All holes drilled into the body panels shall have all burrs & swarf removed then coated with a suitable rust preventative paint.
6. The high tensile fasteners supplied with this product were used to achieve the specified rating. If replacement is required ensure that fasteners of the same rating & quality are used. Contact an authorized **Trailboss** dealer if further information is required.
7. Ensure that all hardware is fastened to torque list below check fasteners on regular basis.
8. Tow bar load rating sticker provided with this product shall be conspicuously located on inside rear end of the driver's door. **(See diagram below).**
9. Trailboss recommends that you check your tow ball to ensure that it complies with the Australian standards **AS 4177.2**.
10. **PLEASE NOTE:** It is advised to remove your lug or tbn when not actually towing so as to produce a clear view of the vehicles registration plate if obscured, and to also provide maximum available departure angle

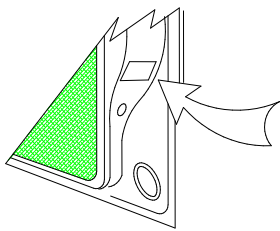

Place load rating sticker
inside driver's door here

FOR TOWING PURPOSES ONLY

For towing capacity details please refer to vehicle owner's manual or to the manufacturer. Overloading can void your warranties.

RECOMMENDED ASSEMBLY TORQUE LISTING

Diameter Grade 8.8 Bolt

M6	9.5 Nm
M8	21.7 Nm
M10	43.4 Nm
M12	77.3 Nm
M16	189.8 Nm

Tow bar Maintenance and Care.

Trailboss recommends that bolt torque's, as listed below, are routinely and regularly inspected and checked for correct tension. Replace any worn or defective parts.

We recommended to remove Tow Ball Mounts (TBM's, tongues or lugs) when not being used for any considerable length of time.

So as to avoid injury, when not towing it is suggested that the tongue, Pull Pin and R-clip are removed then stored in a safe, clean and dry place, away from excessive moisture.

Hitch Pull Pins and spring "R" clips are regularly checked for proper installation. Replace any worn or defective parts.

Tow bar Fitting Instructions
To Suit Ford Ute AU, BA, BF & FG (TUB BODY) XR6 & XR8 Only
Part Number QTFD962L
Rating 2300 kg Max Static Ball Load 230Kg

1. **INSTRUCTIONS**

2. Remove spare wheel.
3. Cut bumper if fitting to either a BA-BF or FG XR series vehicle, as shown in diagrams 2, 3 or 4 respectively.
4. Remove exhaust from three rear most rubber hangers,
5. Fit loose angle mounting brackets to under side of rear cross member using four M10x30 taptite bolts supplied. Semis tight see tow bar assembly detail for correct component orientation.
6. Lift tow bar into position and fit six M12 x 100 bolts, loose plates through chassis and tow bar loosely.
7. Fit four M10 x 30 bolts to angle mounting brackets loosely.
8. Fit four M10 x 30 taptite bolts through tow bar and into vertical holes in under side of chassis rail.
9. Tighten all taptite bolts to torque listing.
10. Tighten four M10 x 30 bolts to angle mounting bracket to torque listing.
11. Tighten six M12 x 100 bolts to torque listing.
12. Using holes in tail mounting plate as guide drill 11mm hole.
13. Fit tapped plate on wire through larger hole forward of hole drilled, fit bolt and torque to listing.
14. Refit exhaust and spare wheel.

NOTE: Safety chains may have to be extended, so as not to touch bumper bar.

LOCATION OF BA XR SERIES BUMPER CUT OUT

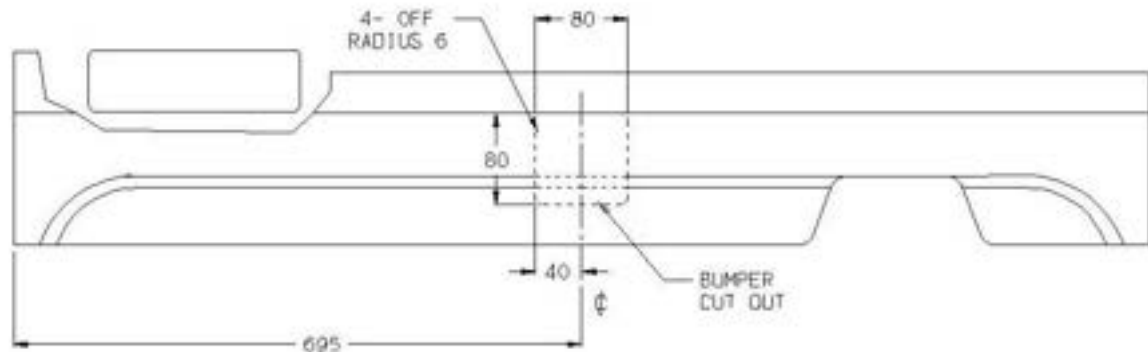

Diagram-2 Location and size of bumper cut out required when installing the tow bar on a BA XR series vehicle.

LOCATION OF BF XR SERIES BUMPER CUT OUT

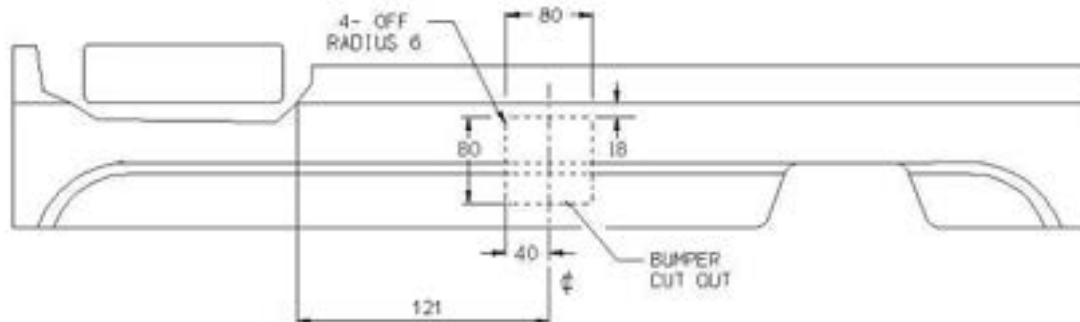

Diagram-3 Location and size of bumper cut out required when installing the tow bar on a BF XR series vehicle.

TRAILBOSS

Tow bar Fitting Instructions
To Suit Ford Ute AU, BA, BF & FG (TUB BODY) XR6 & XR8 Only
Part Number QTFD962L
Rating 2300 kg Max Static Ball Load 230Kg

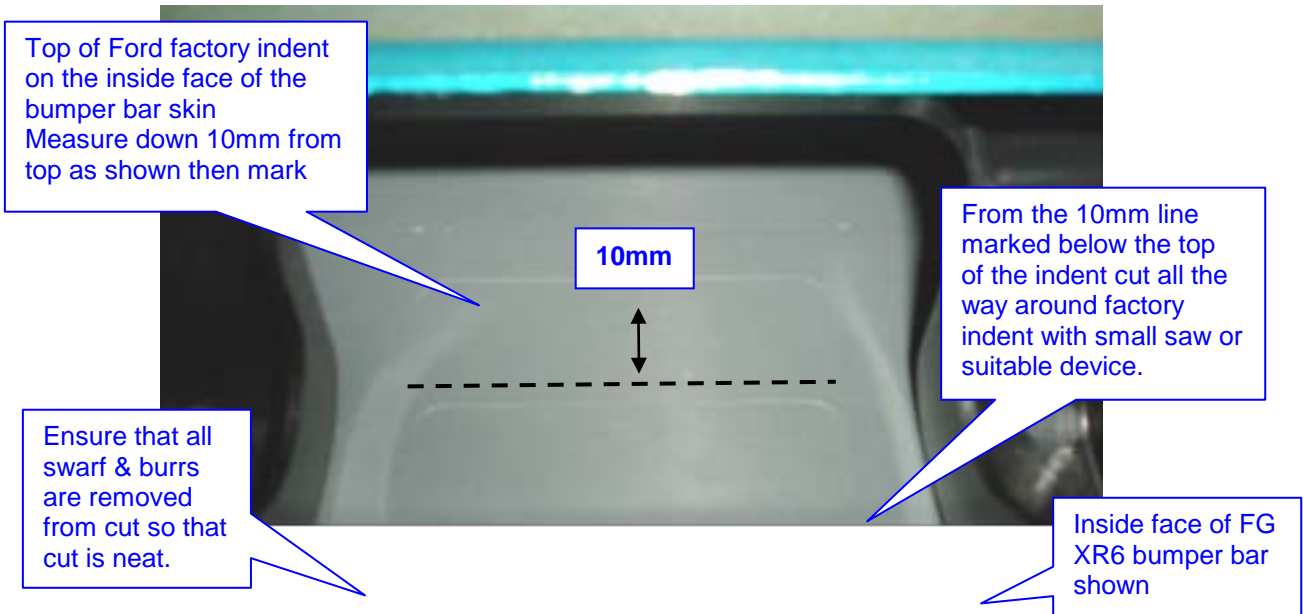
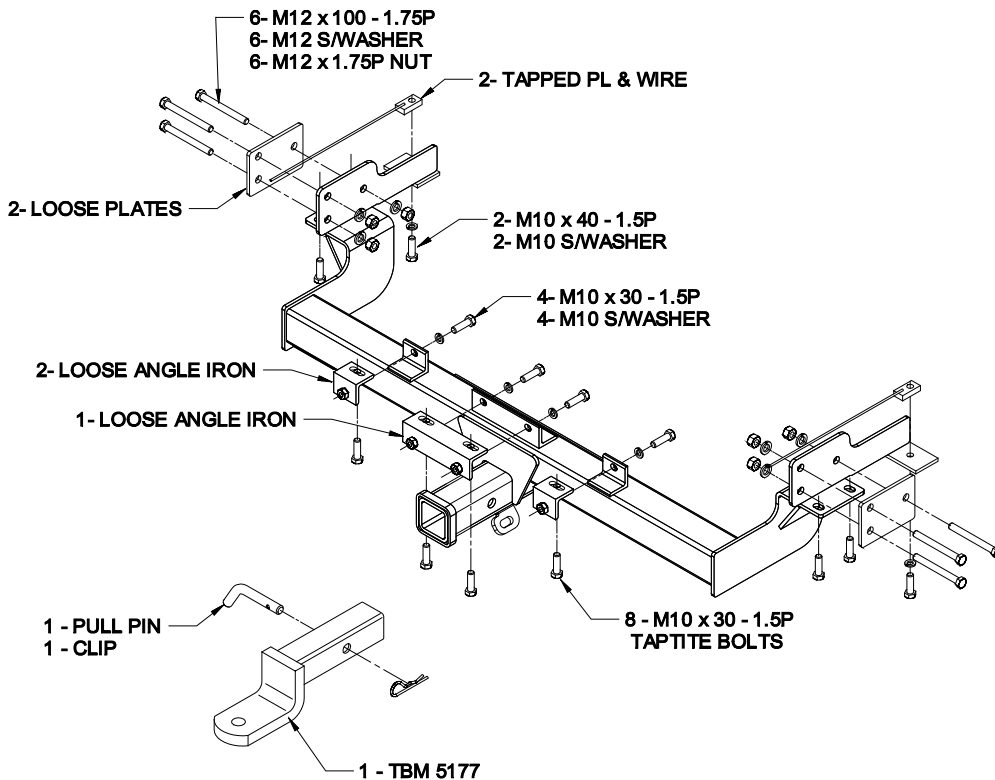

Diagram-4 Location and size of bumper cut out required when installing the tow bar on a FG XR series vehicle.





Wiring Loom Fitting Instructions
To Suit Ford
AU/BA/BF/FG (tug body) XR6/XR8
Falcon AU Cab Chassis (July 1999 onwards)
Falcon AU Cab Chassis (8ft tray)
Falcon Ute Tub Body AU – FG
RTV Cab Chassis & Tub Body

Wiring Loom Installation Instructions

Ford
Part No: 100023-WL

Tail Harness Length Required: 1200mm
RPA Override Switch Part No: 04848 (If Fitted)

Wiring Loom Installation Time: Approx 10 Mins



Wiring Loom Fitting Instructions
To Suit Ford

AU/BA/BF/FG (tug body) XR6/XR8
Falcon AU Cab Chassis (July 1999 onwards)
Falcon AU Cab Chassis (8ft tray)
Falcon Ute Tub Body AU – FG
RTV Cab Chassis & Tub Body

1. Locate the vehicle 8-way Breakout connector underneath the rear of the vehicle.
2. Connect the Trailer Harness Patch (P/N 100023-WL) connector to the 8-way Breakout connector.
3. Secure the Trailer Socket to the vehicle with M4 Fasteners.
4. Connect the Tail Harness (Length 1200mm) to the Trailer Harness Patch.
5. Bundle the excess Tail Harness length up and secure to the existing vehicle harnesses with cable ties (not supplied).
6. Test the Tail Harness socket using a light board or multimeter.
7. Secure the all harnesses using cables ties (not supplied).
8. Refit all removed parts and secure all fasteners.
9. Place instructions in glove box after fitment.