

TRAILBOSS

Towbar Fitting Instructions To Suit **GREAT WALL STEED NBP CL4** Part Number **QTGW007L** Rating **2000/200 kg**

PLACE THESE INSTRUCTIONS IN THE VEHICLE'S GLOVEBOX AFTER INSTALLATION IS COMPLETED

WARNING:

1. Do not, drill, cut, weld or otherwise modify the tow bar.
2. If you are using electric welding on a motor vehicle, **always** check that the vehicle is not equipped with electronic engine or instrument management equipment. Failure to do so could **destroy** any onboard computers. If in doubt, check with the vehicle's manufacturer.
3. The high tensile fasteners supplied with this product were used to achieve the specified rating. If replacement is required ensure that fasteners of the same rating & quality are used. Contact an authorised **Trailboss** dealer if further information is required.
4. If TBM is used in inverted position tow ball may make contact with rear tailgate when lowered, which could cause damage.

General:

1. Ensure all hardware items have been included refer to assembly diagram.
2. It is recommended that the instructions are read through and completely understood before making any attempt to fit this product.
3. Be wary of any changes to vehicle designs or other accessories that may conflict with the installation of this product.
4. Before drilling ensure that the area is clear of fuel, electrical & other components.
5. All holes drilled into the body panels shall have all burrs & swarf removed then coated with a suitable rust preventative paint.
6. For vehicles that require the bumper to be cut. Ensure cut out area is in correct position on the vehicle prior to cutting the bumper.
7. The high tensile fasteners supplied with this product were used to achieve the specified rating. If replacement is required ensure that fasteners of the same rating & quality are used. Contact an authorized **Trailboss** dealer if further information is required.
8. Ensure that all hardware is fastened to torque list below check fasteners on regular basis.
9. Tow bar load rating sticker provided with this product shall be conspicuously located on inside rear end of the driver's door. **(See diagram below)**.
10. Trailboss recommends that you check your tow ball to ensure that it complies with the Australian standards **AS 4177.2**.
11. **PLEASE NOTE:** It is advised to remove your LUG or TBM when not actually towing so as to produce a clear view of the vehicles registration plate if obscured, and to also provide maximum available departure angle

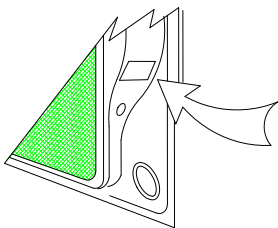

Place load rating sticker
inside driver's door here

FOR TRAILER TOWING PURPOSES ONLY
For towing capacity details please refer to vehicle owner's manual or to the manufacturer. Overloading can void your warranties.

RECOMMENDED ASSEMBLY TORQUE LISTING

Diameter Grade 8.8 Bolt

M6	9.5 Nm
M8	21.7 Nm
M10	43.4 Nm
M12	77.3Nm
M14	146 Nm
M16	189.8 Nm

Tow bar Maintenance and Care.

Trailboss recommends that bolt torque's, as listed below, are routinely and regularly inspected and checked for correct tension. Replace any worn or defective parts.

We recommended to remove Tow Ball Mounts (TBM's, tongues or lugs) when not being used for any considerable length of time.

So as to avoid injury, when not towing it is suggested that the tongue, Pull Pin and R-clip are removed then stored in a safe, clean and dry place, away from excessive moisture.

Hitch Pull Pins and spring "R" clips are regularly checked for proper installation. Replace any worn or defective parts.

Cequent Customer Service

Ph: 1800 812 017 Fax: 03 9898 3299

Email: info@cequent.com.au

Post: PO Box 4050, Dandenong South VIC 3175

TRAILBOSS

Towbar Fitting Instructions
 To Suit **GREAT WALL STEED NBP CL4**
 Part Number **QTGW007L**
 Rating **2000/200 kg**

PLACE THESE INSTRUCTIONS IN THE VEHICLE'S GLOVEBOX AFTER INSTALLATION IS COMPLETED

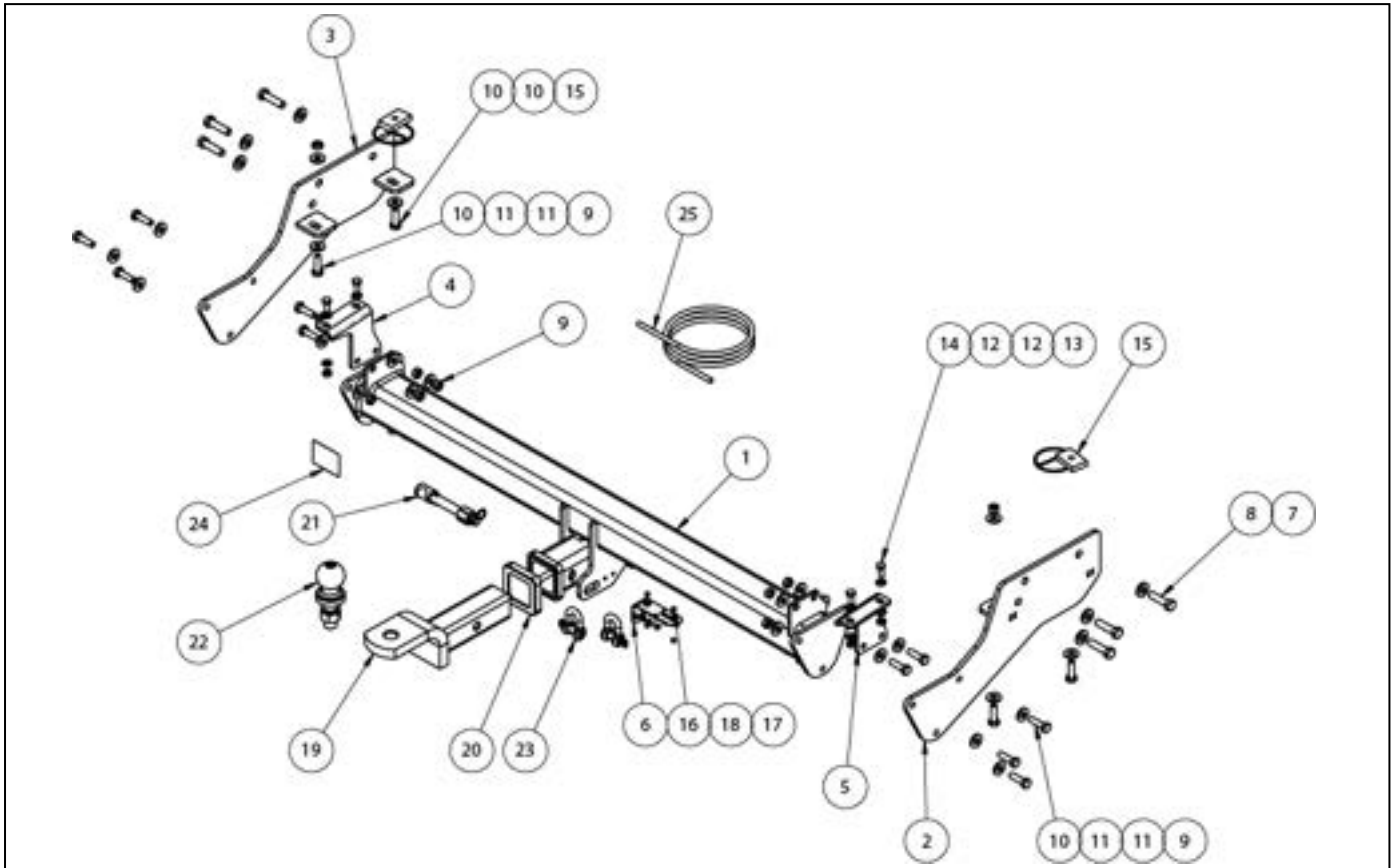

ITEM	DESCRIPTION	QTY
1	WELDED ASSEMBLY	1
2	SIDE ARM ASSY RH	1
3	SIDE ARM ASSY LH	1
4	STEP BRACKET LH	1
5	STEP BRACKET RH	1
6	UNIVERSAL PLUG BRACKET KIT	1
7	WASHER PLAIN 1/2x1-1/8x16G	6
8	SET SCREW HEX HD M12x45x1.25P	6
9	NUT HX M10-1.25Z/P	12
10	SET SCREW HEX HD M10x35x1.25P	14
11	WASHER FT M10x25.4x3	26
12	WASHER FT M8x17x1.20Z/P	8
13	NUT M8-1.25	4

ITEM	DESCRIPTION	QTY
14	SET SCREW HX HD M8x20x1.25P G8.8	4
15	FITTING PLATE M10 TAP WITH 300MM WIRE	2
16	SCREW PAN HD M4x16x0.7P G4.6	2
17	NUT NYLON LOCK HEX HD M4x0.7P G8	2
18	WASHER PLAIN 3/6x1/2x20G	2
19	TRAILER BALL MOUNT	1
20	HITCH BOX COLLAR COVER	1
21	ANTI-RATTLE PULL PIN ASSY SILVER	1
22	TOWBALL 50MM	1
23	"D" SHACKLE 10MM	2
24	ACRYLIC COMPLIANCE LABEL	1
25	WIRING LOOM	1

Cequent Customer Service
 Ph: 1800 812 017 Fax: 03 9898 3299
 Email: info@cequent.com.au
 Post: PO Box 4050, Dandenong South VIC 3175

TRAILBOSS

Towbar Fitting Instructions
To Suit **GREAT WALL STEED NBP CL4**
Part Number **QTGW007L**
Rating **2000/200 kg**

PLACE THESE INSTRUCTIONS IN THE VEHICLE'S GLOVEBOX AFTER INSTALLATION IS COMPLETED

1. Remove rear step by removing 3 x M12 bolts per side.
Ensure to disconnect wiring harness.

Retain rear step for re-fitment.



2. Loosely secure side arm to the chassis side rail with 3 x M12 x 1.25P bolts complete with 1 x washer per bolt.

Repeat for opposite side.



3. Loosely secure the front arm support with 1x M10 x 35 bolt complete with 1 x washer and 1 x M10 nut on wire.
4. Loosely secure the rear arm support with 1 x M10 x 1.25 x 35 bolt complete with 2 x washers and 1 x M10 nut.
5. Repeat steps 3 and 4 for opposite side.



Cequent Customer Service
Ph: 1800 812 017 Fax: 03 9898 3299
Email: info@cequent.com.au
Post: PO Box 4050, Dandenong South VIC 3175

TRAILBOSS

Towbar Fitting Instructions
To Suit **GREAT WALL STEED NBP CL4**
Part Number **QTGW007L**
Rating **2000/200 kg**

PLACE THESE INSTRUCTIONS IN THE VEHICLE'S GLOVEBOX AFTER INSTALLATION IS COMPLETED

6. Lift cross tube to side arms and secure each side with 3 x M10 x 1.25P x 35 bolts complete with 2 x washers and 1 x nut per bolt.



7. Secure LH Step Bracket to the assembly using 2 x M10 x 1.25P x 35 bolts complete with 2 x washers and 1 x nut per bolt.

NOTE: Bracket must be on the outside face of the assembly with the bend facing outwards.

Repeat for opposite side.

Torque all fasteners accordingly:
M12: 125Nm
M10: 48Nm



8. On the rear step assembly remove the plastic cover from the step support as follows:
- Unclip the step covers.
 - Remove 12 x M6 countersunk bolts (top) and the 6 x Hex bolts on underside edge.
 - Disconnect the wiring loom



Cequent Customer Service
Ph: 1800 812 017 Fax: 03 9898 3299
Email: info@cequent.com.au
Post: PO Box 4050, Dandenong South VIC 3175

TRAILBOSS

Towbar Fitting Instructions
To Suit **GREAT WALL STEED NBP CL4**
Part Number **QTGW007L**
Rating **2000/200 kg**

PLACE THESE INSTRUCTIONS IN THE VEHICLE'S GLOVEBOX AFTER INSTALLATION IS COMPLETED

9. On the steel step support, remove the 4 x M10 bolts (2 per side) and discard the side arm brackets.



10. Re-attach the rear step support to the towbar assembly and secure with 4 x M8 x 1.25P bolts complete with 2 x washers and 1 x M8 nut per bolt.

Torque M8 fasteners to 20Nm



11. Re-attach rear step plastic covers by completing step 8 in reverse.



Cequent Customer Service
Ph: 1800 812 017 Fax: 03 9898 3299
Email: info@cequent.com.au
Post: PO Box 4050, Dandenong South VIC 3175



Wiring Loom Fitting Instructions
To Suit GWM STEED
Part Number 100192-WL

Wiring Loom Installation Instructions

GWM STEED
Part No: 101797-WL

Tail Harness Length Required: 04936
ECU Required: 04837

Wiring Loom Installation Time: Approx 60 Mins



Wiring Loom Fitting Instructions
To Suit GWM STEED
Part Number 100192-WL

1. Open bonnet exposing vehicles engine bay.
2. In the engine bay, disconnect the negative battery terminal.
3. Route the Power Lead up to the battery, following the existing vehicle harness.
4. Connect the Power Lead Ring Terminal to the positive battery terminal.
5. Secure the Power Lead to the existing vehicle harnesses with the supplied cable ties.
6. Route the harness from the battery under the vehicle towards the rear underside of the vehicle (to the location of the ECU).
7. On the LHS of the tray, remove the two bolts before removing the tray door catch.
8. Remove the bolt located next to the tray door catch and the bolt beneath the tray door arm. Repeat for RHS.
9. Dislodge the LHS tail lamp.
10. Disconnect the LHS tail lamp connector before removing the LHS tail lamp. Repeat for RHS.
11. In the front Passenger wheel arch area, remove the vehicle sway bar bracket bolt as shown.
12. Remove the upper cover fastener and fold back the upper cover.
13. Feed the supplied M6 Flat Washer into the M6 Bolt. Push the bolt through the hole located behind the upper cover.
14. On the other side the chassis feed an M6 Star Washer and the 6mm end of the Ground Patch into the Bolt.
15. Secure assembly using an M6 Nyloc Nut.
16. Route the Ground Patch down behind the chassis rail towards the vehicle sway bar bracket.
17. Secure the 8mm end of the Ground Patch to the vehicle sway bar bracket using the previously removed bolt.
18. At the rear of the vehicle, route the RHS of the Trailer Wiring Harness up the RHS of the vehicle and out into the RHS tail lamp cavity.
19. Connect the Trailer Wiring Harness to the tail lamp connector.
20. Route the Trailer wiring Harness towards the LHS of the vehicle as shown and secure using cable ties (not supplied).
21. Route the LHS of the Trailer Wiring Harness up the LHS of the vehicle and out into the LHS tail lamp cavity.



Wiring Loom Fitting Instructions
To Suit GWM STEED
Part Number 100192-WL

22. Connect the Trailer Wiring Harness to the tail lamp connector.
23. Clean the inside of the LHS tail lamp and the underside of the ECU Module with a Cleaning Pad as shown (not supplied).
24. Secure ECU behind LHS tail as shown.

Important: Ensure ECU cable and connector is facing down.

25. Attach ring terminal to grounding point.
26. Connect the power line to trailer wire harness.
27. Under the LHS of the vehicle, locate the vehicle 6-way rear connectors.
28. Disconnect the 6-way connectors and patch in the mating connectors from the Trailer Harness.
29. Connect the tail harness 8-way connector to the trailer patch 8-way mating connector.
30. To enable RPA cut-off, crimp the tail harness GREY and GREY/BLACK wires to the trailer patch matching GREY and GREY/BLACK wires.
31. Apply silicone grease to waterproof connector.
32. Re-connect negative battery terminal.
33. Test the trailer patch function using a light board or multi-meter.
34. Secure all harnesses using cable ties (not supplied).
35. Re-fit all removed parts and secure all fasteners, ensuring there are no squeaks or rattles.
36. Place the fitting instructions in the glove box after fitment.



FITTING INSTRUCTIONS

Silent Anti-Rattle Hitch Pin (PR0001)

• These fitting instructions are supplied to ensure understanding of how the HITCH PIN should be fitted and used correctly.

• Once installed, we recommend **ALL** instructions are kept and placed in the vehicle glove box.

NOTE: Routine maintenance and inspection of the towbar & HITCH PIN is required. Regularly inspect for wear and check the tightness of the Hitch Pin. Follow instructions below to retighten the nut when necessary.

***Do not tow with your vehicle if the R CLIP or the HITCH PIN is loose or missing. Replacement parts are available from your Pro Series Distributor.**

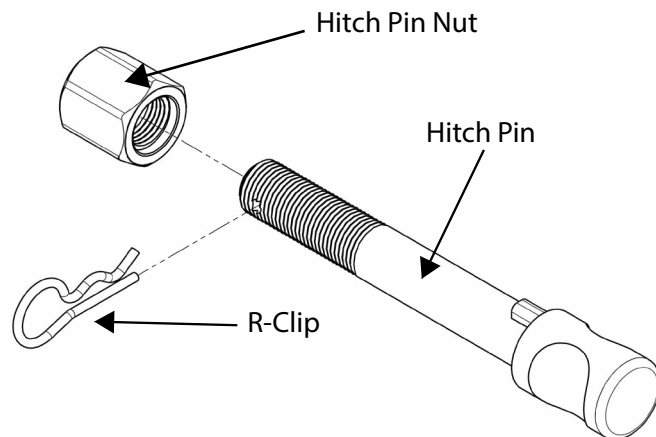

Fig 1. Silent Anti-Rattle Hitch Pin assembly

STEP 1

Insert Trailer Ball Mount (TBM) into towbar HITCHBOX, aligning hole in TBM SHANK with hole in HITCHBOX (Fig 2).

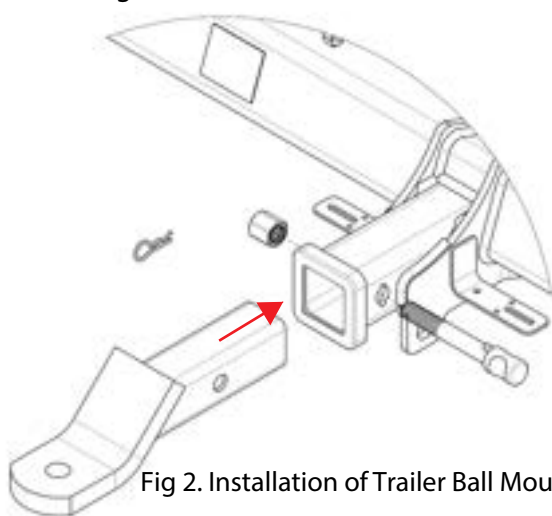

Fig 2. Installation of Trailer Ball Mount

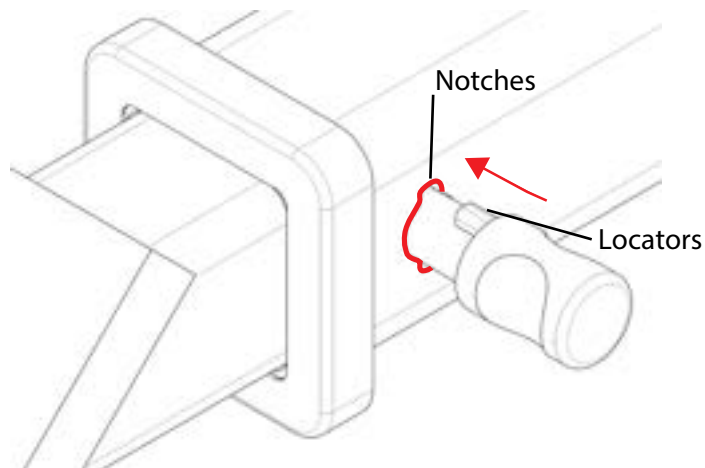

Fig 3. Silent Anti-Rattle Hitch Pin orientation

STEP 2

Insert HITCH PIN through hole in HITCHBOX and hole in TBM SHANK; ensure the LOCATORS are inserted into the NOTCHES in the HITCHBOX (Fig. 3).

STEP 3

Screw HITCH PIN NUT onto HITCH PIN ; tighten HITCH PIN NUT until finger tight, ensuring TBM is restrained from movement.

STEP 4

Tighten HITCH PIN NUT by turning nut a further 1/8th of a turn in the clockwise direction using a 24mm spanner (Fig. 4).

STEP 5

Install HITCH PIN R CLIP through the hole on the HITCH PIN (Fig. 1).

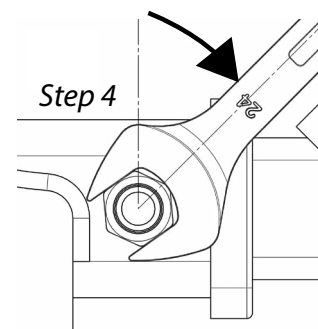

Fig 4. Tightening of Silent Anti-Rattle Hitch Pin Nut