

TRAILBOSS

Towbar Fitting Instructions To Suit Holden Rodeo 03-on All Models Part Number QTHD312L Max. Tow Rating: 2500Kg Ball Weight: 250Kg

1. Ensure all hardware items have been included.
2. Lift towbar into position to align outer most towbar holes with chassis holes. Fit 6 M12x30 bolts loosely.
3. Loosely fit angle brackets with remaining bolts as shown in diagram.
4. For 2006 & 2007 update variants remove wires from bolts see diagram below.
5. Tighten all bolts to torque listing below.

RECOMMENDED ASSEMBLY TORQUE LISTING

<u>Diameter</u>	<u>Grade 8.8 Bolt</u> <u>Nm</u>
M6	9.5
M8	21.7
M10	43.4
M12	77.3
M14	121.0
M16	189.8

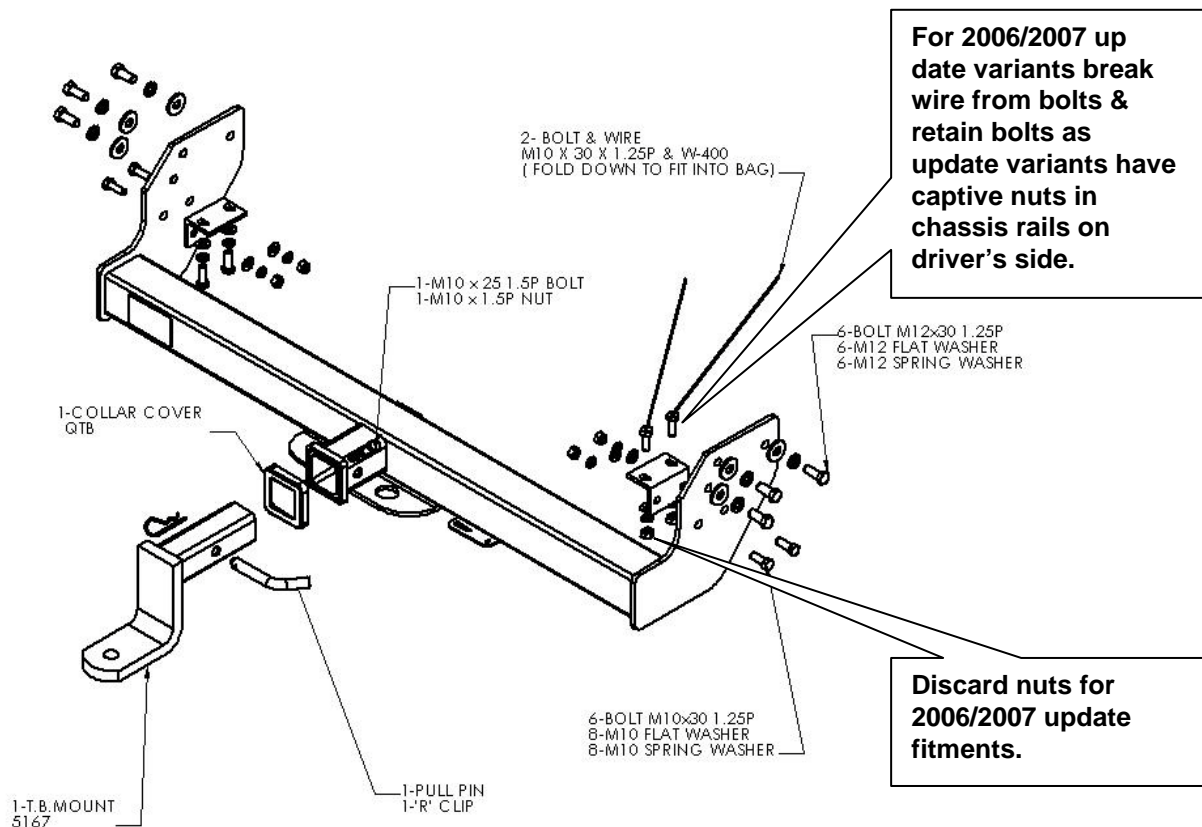



Wiring Loom Fitting Instructions
To Suit Holden Rodeo
Rodeo LT 4x4 Turbo Diesel
Rodeo LT 4x4 Turbo Diesel (2001 to 2007)
Rodeo 2WD & 4WD

Part Number 100055-WL

Wiring Loom Installation Instructions

Holden Rodeo
Part No: 100055-WL

Tail Harness Length Required: 1200mm
RPA Override Switch Part No: 04848 (If Fitted)

Wiring Loom Installation Time: Approx 20 Mins



Wiring Loom Fitting Instructions
To Suit Holden Rodeo
Rodeo LT 4x4 Turbo Diesel
Rodeo LT 4x4 Turbo Diesel (2001 to 2007)
Rodeo 2WD & 4WD

Part Number 100055-WL

1. Underneath the rear of the vehicle, locate and disconnect the LHS vehicle trailer break-out connector.
2. Secure the Tail Harness socket onto the towbar mounting bracket with fasteners.
3. Connect the Trailer Patch Harness (part no. 100055-WL) to the LHS break-out connector.
4. Route Tail Harness (length 1200mm) towards the Trailer Patch Harness and connect the Trailer Patch Harness to the Trailer tail Harness.
5. Secure the Trailer Patch Harness relays onto the interior vehicle sheet metal using tech screws. Secure the vehicle patch harness and Tail Harness connectors using cable ties (not supplied).
6. Test the Trailer socket using a light board or multi-meter.
7. Secure the all harnesses using cables ties (not supplied).
8. Refit all removed parts and secure all fasteners.
9. Place instructions in glove box after fitment.