

TRAILBOSS

Towbar Fitting Instructions
To Suit **COLORADO WITHOUT STEP 08/2012 - ON**
Part Number **QTHD471L**
Rating **3500 kg**

PLACE THESE INSTRUCTIONS IN THE VEHICLE'S GLOVEBOX AFTER INSTALLATION IS COMPLETED

WARNING:

1. Do not, drill, cut, weld or otherwise modify the tow bar.
2. If you are using electric welding on a motor vehicle, **always** check that the vehicle is not equipped with electronic engine or instrument management equipment. Failure to do so could **destroy** any onboard computers. If in doubt, check with the vehicle's manufacturer.
3. The high tensile fasteners supplied with this product were used to achieve the specified rating. If replacement is required ensure that fasteners of the same rating & quality are used. Contact an authorised **Trailboss** dealer if further information is required.

General:

1. Ensure all hardware items have been included refer to assembly diagram.
2. It is recommended that the instructions are read through and completely understood before making any attempt to fit this product.
3. Be wary of any changes to vehicle designs or other accessories that may conflict with the installation of this product.
4. Before drilling ensure that the area is clear of fuel, electrical & other components.
5. All holes drilled into the body panels shall have all burrs & swarf removed then coated with a suitable rust preventative paint.
6. For vehicles that require the bumper to be cut. Ensure cut out area is in correct position on the vehicle prior to cutting the bumper.
7. The high tensile fasteners supplied with this product were used to achieve the specified rating. If replacement is required ensure that fasteners of the same rating & quality are used. Contact an authorized **Trailboss** dealer if further information is required.
8. Ensure that all hardware is fastened to torque list below check fasteners on regular basis.
9. Tow bar load rating sticker provided with this product shall be conspicuously located on inside rear end of the driver's door. **(See diagram below)**.
10. Trailboss recommends that you check your tow ball to ensure that it complies with the Australian standards **AS 4177.2**.
11. **PLEASE NOTE:** It is advised to remove your lug or tbm when not actually towing so as to produce a clear view of the vehicles registration plate if obscured, and to also provide maximum available departure angle
12. Pull Pin must be fit in down position.

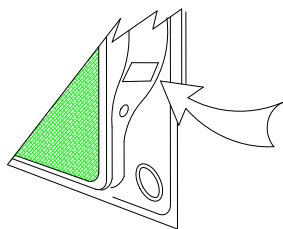

Place load rating sticker
inside driver's door here

FOR TRAILER TOWING PURPOSES ONLY
For towing capacity details please refer to vehicle owner's manual or to the manufacturer. Overloading can void your warranties.

RECOMMENDED ASSEMBLY TORQUE LISTING

Diameter	Grade 8.8 Bolt
M6	9.5 Nm
M8	21.7 Nm
M10	43.4 Nm
M12	77.3Nm
M14	146 Nm
M16	189.8 Nm

Tow bar Maintenance and Care.

Trailboss recommends that bolt torque's, as listed below, are routinely and regularly inspected and checked for correct tension. Replace any worn or defective parts.

We recommended to remove Tow Ball Mounts (TBM's, tongues or lugs) when not being used for any considerable length of time.

So as to avoid injury, when not towing it is suggested that the tongue, Pull Pin and R-clip are removed then stored in a safe, clean and dry place, away from excessive moisture.

Hitch Pull Pins and spring "R" clips are regularly checked for proper installation. Replace any worn or defective parts.

Rev: **A**

Page 1

Issue Date **13-07-2012**

Cequent Customer Service
Ph: 1800 812 017 Fax: 03 9898 3299
Email: info@cequent.com.au
Post: PO Box 4050, Dandenong South VIC 3175

TRAILBOSS

Towbar Fitting Instructions To Suit COLORADO WITHOUT STEP 08/2012 - ON Part Number QTHD471L Rating 3500 kg

PLACE THESE INSTRUCTIONS IN THE VEHICLE'S GLOVEBOX AFTER INSTALLATION IS COMPLETED

1. With assistance bolt Towbar to vehicle using Nut Plate and 2 M12x45 Bolts for both RH & LH side on the underside of the Chassis Rail.
2. Bolt 3 M12x45 with Flat Washers into Side Plates for both the RH & LH side.
3. Tighten all Bolts to recommended Assembly Torque shown in Page 2.

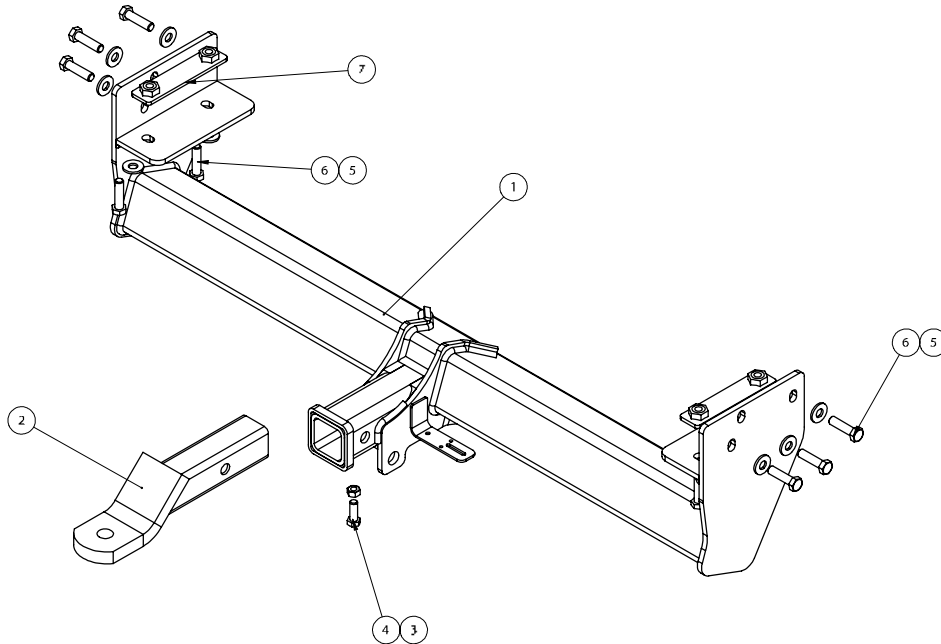

ITEM NO.	DESCRIPTION	QTY.
1	WELD ASSEMBLY WITHOUT STEP	1
2	TRAILER BALL MOUNT	1
3	HEX NUT M10x1.5	1
4	SET SCREW HEX HD M10x30x1.5P	1
5	WASHER M12x28.8x3mm	10
6	SET SCREW M12x45x1.25P	10
7	NUT PLATE	2

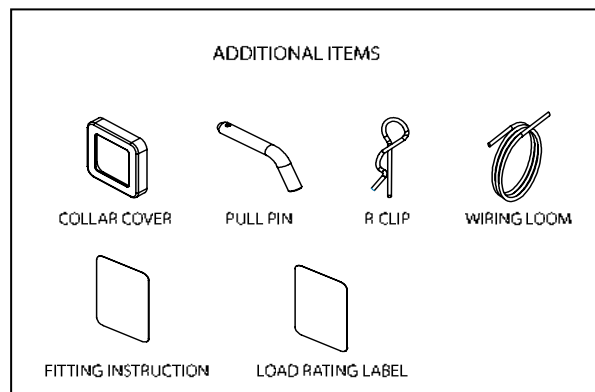

Rev: A

Page 2

Issue Date 13-07-2012

Cequent Customer Service
Ph: 1800 812 017 Fax: 03 9898 3299
Email: info@cequent.com.au
Post: PO Box 4050, Dandenong South VIC 3175



Wiring Loom Fitting Instructions
To Suit Holden Colorado MY12 (08/2012 – Onwards)
Part Number 100819-WL

Wiring Loom Installation Instructions

Holden Colorado MY12
(08/2012 – Onwards)

Part No: 100819-WL

Tail Harness Length Required: 400mm
ECU: WLT030 - LTZ Models (Hi-Spec)
ECU: WLT033 - DX, LX, LT Models (Low-Spec)

Wiring Loom Installation Time: Approx 45 Mins



Wiring Loom Fitting Instructions
To Suit Holden Colorado MY12 (08/2012 – Onwards)
Part Number 100819-WL

1. On the rear of the vehicle, underneath the rear bumper on the RHS, disconnect the 6-way tail light assembly connectors and connect the trailer patch (100819-WL) in between.
2. Route the trailer harness along the rear tow bar towards the LHS of the vehicle tail light and secure with cable ties (not supplied).
3. On the LHS of the vehicle, disconnect the tail light 6-way assembly connectors and connect the trailer patch connectors in between.
4. On the LHS, underneath the rear bumper, using a tech screw, secure the ground ring terminal to the metal sheet.

Note: Spray rust prevention inhibitor.

5. Connect the 24-way waterproof ECU connector to the ECU (WLT030).
6. Secure the ECU onto the metal sheet above the tail light connectors, using tech screw.

Note: Spray rust prevention inhibitor.

7. Connect the 1-way connector to the power harness 1-way connector.
8. Route the 'ORANGE' power wire towards the front of the vehicle along the chassis rail.
9. In the engine bay, remove the fuse panel cover and secure the ring terminal to the positive post.
10. Mount the trailer socket to the towbar mounting bracket using M4 fasteners (not supplied).
11. Route the tail harness towards the trailer harness mating connector.
12. Waterproof the Trailer Harness 8-way connector and the tail harness 8-way male connector using silicone or grease.
13. Connect the Tail Harness 8-way connector to the trailer patch 8-way mating connector.
14. Test the Trailer Harness function using a light board or multimeter.
15. Secure all harnesses using cables ties (not supplied).
16. Re-fit all removed parts and secure all fasteners, ensuring there are no squeaks or rattles.
17. Place the instructions in the glove box after fitment.