

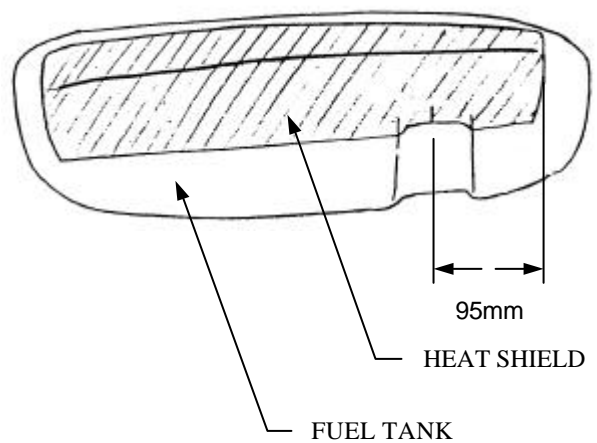

Towbar Fitting Instructions
To Suit HOLDEN MONARO
Part Number QTHD490
Rating 1600Kg

1. Remove boot carpet and spare wheel.
- 3A. Removal of rear bumper bar (MONARO).
 - a. Remove four self taper screws from each wheel arch and mud flaps if fitted.
 - b. Remove two plastic trim buttons, attaching bumper to rear panel from under car.
 - c. Remove 4 plastic trim buttons from under weather seal of boot lid.
 - d. Remove 4mm nuts, two each side, from inside boot behind rear quarter panel trim.
 - e. Remove bumper assembly by pulling outwards from wheel arch to release clips, then sliding rearward.
- 3B. Removal of rear bumper bar (HSV COUPE).
 - a. Remove two self taper screws from each wheel arch.
 - b. Remove four plastic trim buttons, two attaching bumper to rear panel from under car and one either side at wheel arch.
 - c. Remove 4 plastic trim buttons from under weather seal of boot lid.
 - d. Remove 4mm nuts, two each side, from inside boot behind rear quarter panel trim.
 - e. Remove bumper assembly by pulling outwards from wheel arch to release clips, then sliding rearward.
4. Remove impact beam and discard. **NOTE: Tool required TORX T50 on some vehicles.**
5. Remove impact beam mounting brackets and discard.
6. Fit towbar to studs, passenger side first then over stud in under side of boot floor, if fitted, then driver side, for impact beam with (original) nuts, (supplied) flat washers and shake proof washers. Tighten finger tight only.
NOTE: Some vehicles may have extra studs in under side of boot floor, either side of petrol tank fixing point, remove nut and discard.
NOTE: Remove any sealant or body deadener material that may interfere with the correct fitment of plates.
7. Using holes in tail plate as a guide drill Ø 11mm holes up through panel into spare wheel well.
8. Fit two M10x 40 1.5P coach bolts, boot plate, loose plates 40 x 6 x 40 Ø11 hole, spring washers and nuts as per diagram.
9. Using holes in tabs welded to cross member as guides, drill Ø 11mm holes through panel into spare wheel well.
10. Fit two M10x 40 1.5P coach bolts, loose plates 45 x 6 x 45 Ø11 hole, spring washers and nuts as per diagram.
11. Tighten all bolts to torque listing below.
12. Fit fuel tank heat shield as shown in diagram.
13. Cut bumper as per diagram.
14. Refit bumper in reverse of step 3.
15. Refit spare wheel, carpet and trim panels.
16. Attach the plastic hitch box collar by applying firm even pressure.
17. Insert the tongue into the hitchbox and secure with "R" clip and pull pin.

Towbar Fitting Instructions
 To Suit HOLDEN MONARO
 Part Number QTHD490
 Rating 1600Kg

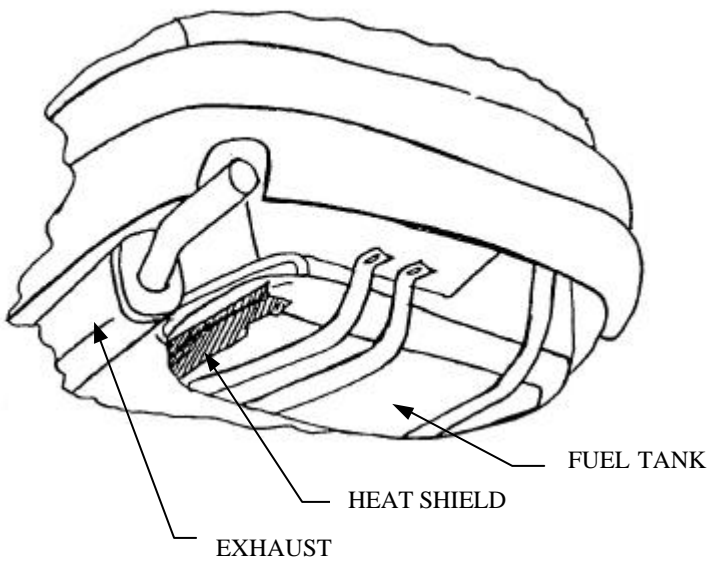
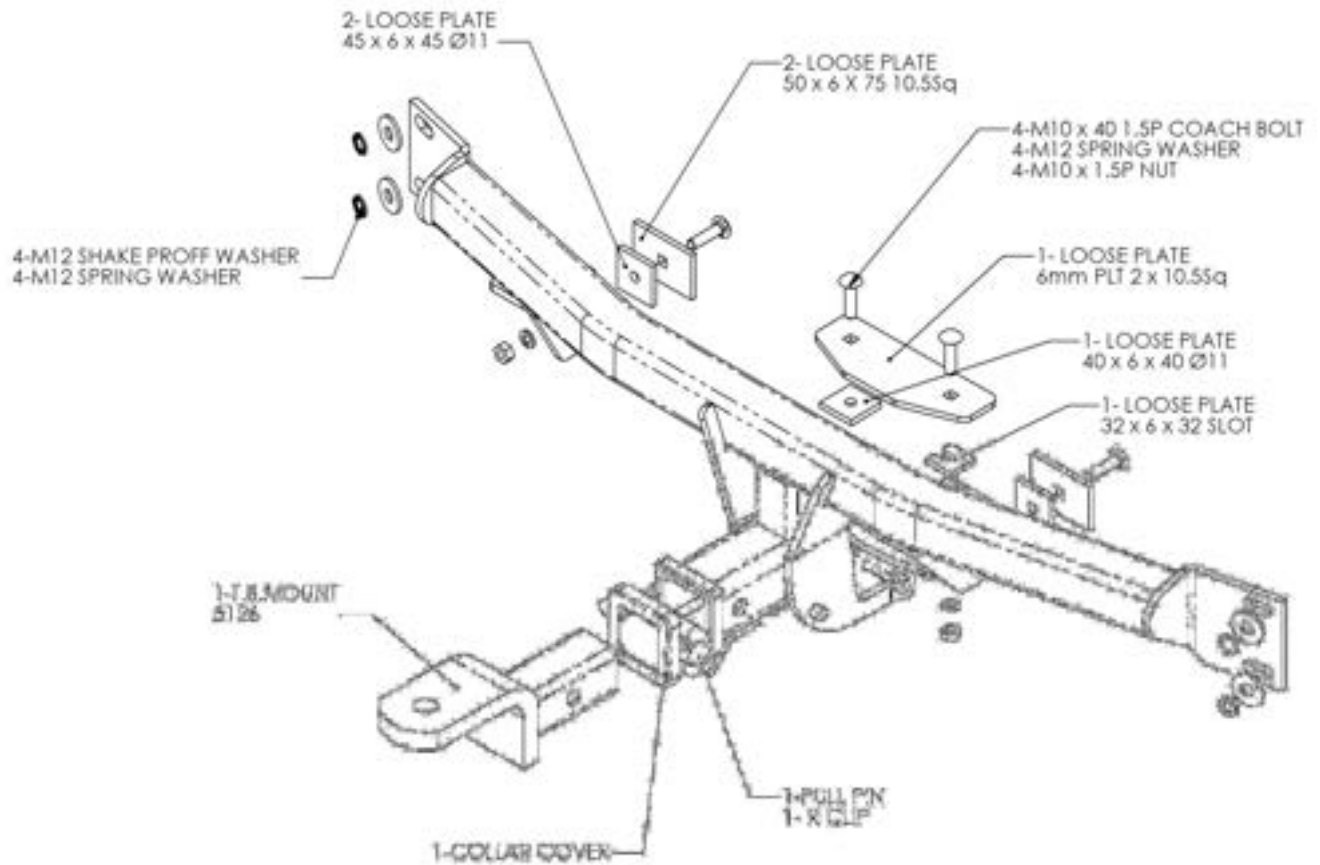

Towbar Fitting Instructions
To Suit HOLDEN MONARO
Part Number QTHD490
Rating 1600Kg

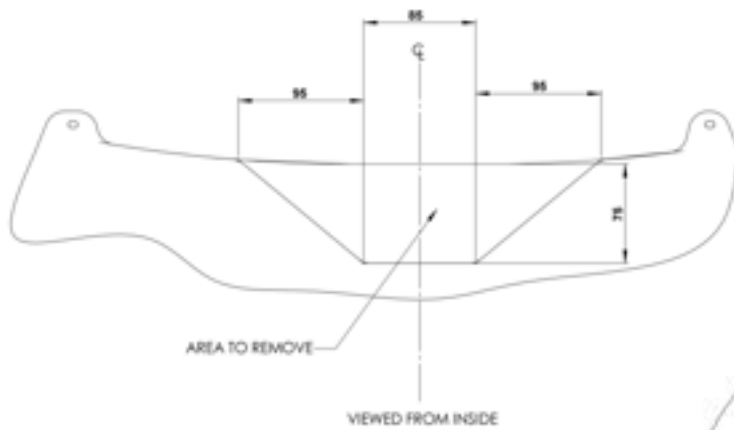

HSV COUPE BUMPER CUT

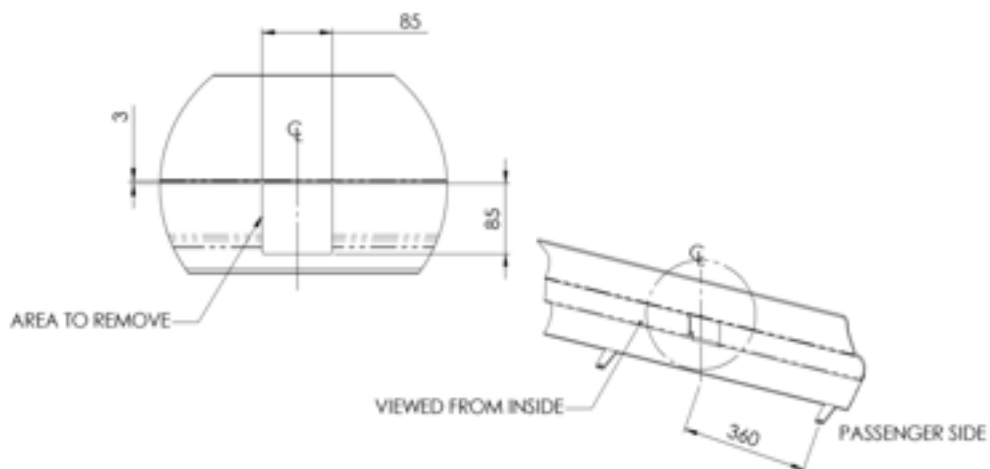
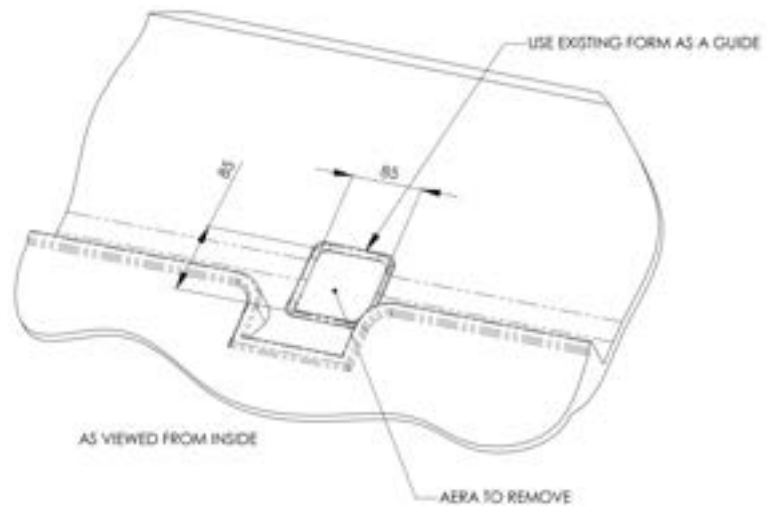

MONARO BUMPER CUT